

Product description **Contacts: 6+PE, cable plug connector with pinch ring, PG 13.5 with VDE, ETS, UL approval, screw,**
Area **RD24 Power Series 692/693**
Order number **99 4217 14 07**

Illustration

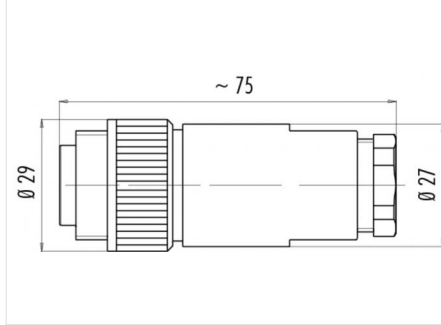

Scale drawing



Contact arrangement

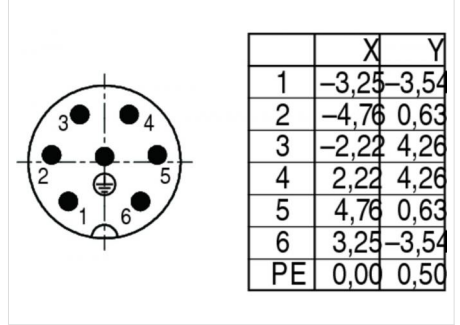

Derating curve

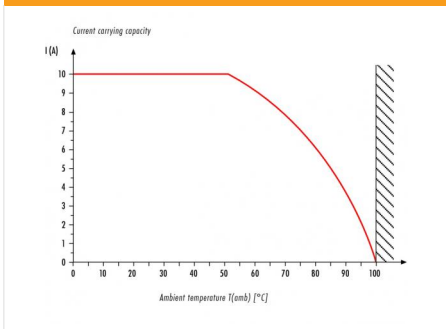

You can find the component part drawing and assembly instructions on the next page.

Technical data

General values

Connector design	cable connector
Connector locking system	bolted
Termination	screw clamp
Wire gauge (mm)	max. 1,5 mm ²
Wire gauge (AWG)	max. 16
Cable outlet	10,0 - 12,0 mm
Upper limit temperature	100 °C
Lower limit temperature	-40 °C

Cable data

Approval 1	UL
Approval 2	ESTI+
Approval 3	VDE

Electrical values

Rated current (40 °C)	10 A (8 A UL)
Rated voltage	250 V
Rated impulse voltage	4000 V
Pollution degree	3
Overvoltage category	III
Insulating material group	III
Volume resistivity	≤ 5 mΩ
Insulation resistance	≥ 10 ¹⁰ Ω
EMC compliance	Shielding is not possible
Degree of protection	IP67
Mechanical operation	> 500 Mating cycles

Material

Contact material	CuZn (brass)
Contact plating	Ag (silver)
Contact body material	PBT (UL 94 V-0)

Product description **Contacts: 6+PE, cable plug connector with pinch ring, PG 13.5 with VDE, ETS, UL approval, screw,**
Area **RD24 Power Series 692/693**
Order number **99 4217 14 07**

Component part drawing

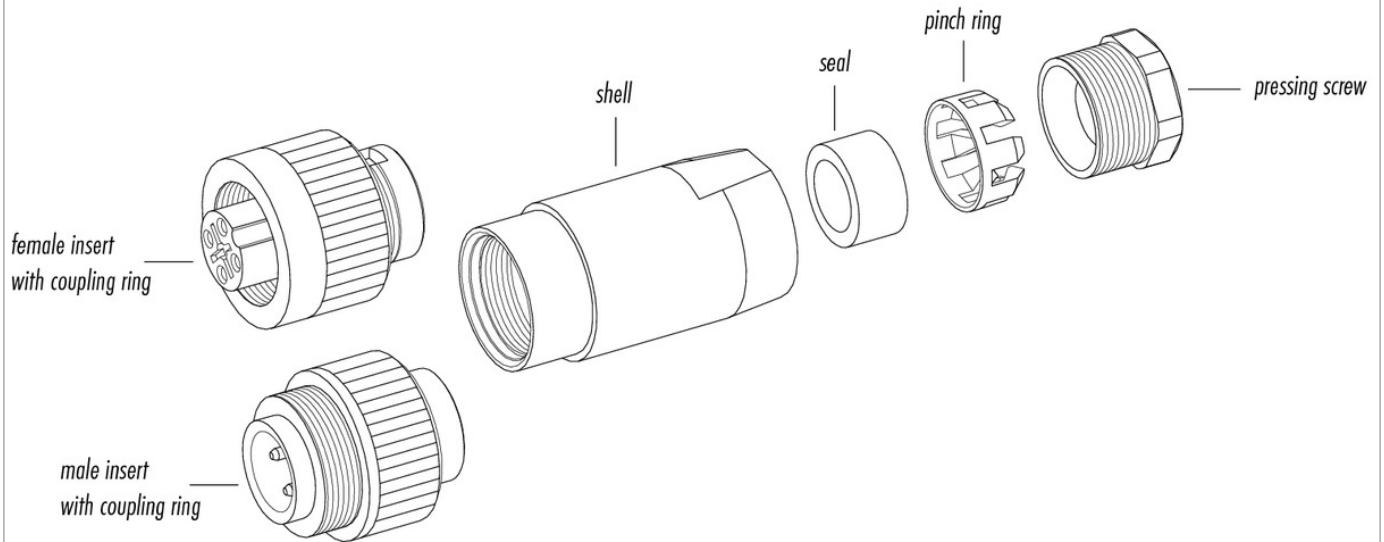

Assembly instructions / Panel cut-out

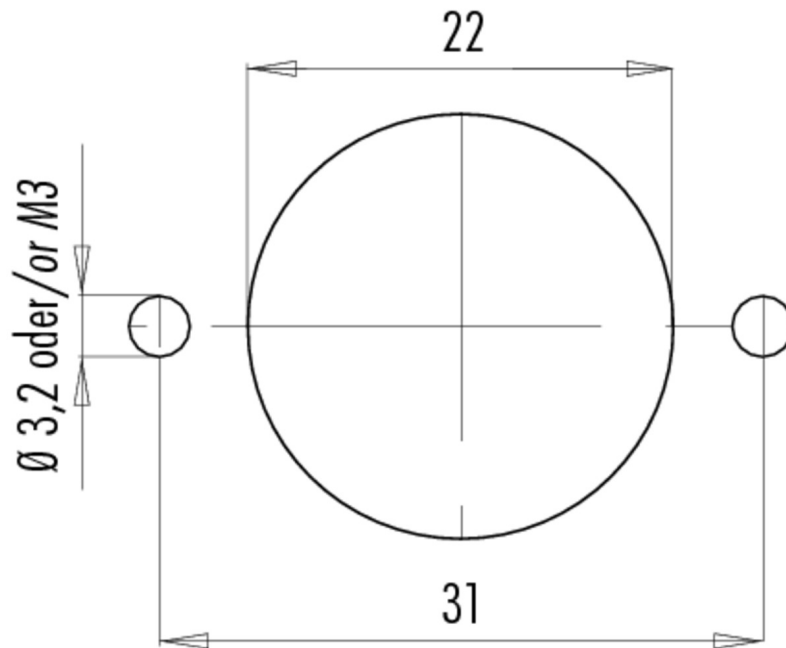

Product description	Contacts: 6+PE, cable plug connector with pinch ring, PG 13.5 with VDE, ETS, UL approval, screw,
Area	RD24 Power Series 692/693
Order number	99 4217 14 07

Security notices

The connector must not be connected or separated under load. Non-observance and incorrect use can result in personal injury.

The connectors are designed for use in plant, control system and electrical equipment. The end user is responsible for checking whether the connectors are suitable for use in other applications.

To prevent the connector being opened unintentionally when used in electrical circuits containing hazardous life parts, the thread between the housing and the connector head must be secured using a suitable cyanoacrylate adhesive. This does not apply to connectors used in SELV and PELV circuits according to IEC 61140 (EN 61140, VDE 0140-1).

Connectors used in electrical circuits containing hazardous life parts must only be assembled and used by or under the supervision of persons with the requisite electrotechnical training, taking the applicable regulations and standards into account.

Connectors with degree of protection IP 67 and IP 68 are not suitable for use under water. When used outdoors, the connectors must be separately protected against corrosion. For further information about IP degrees of protection refer to 'Technical support' in the Download Centre.

To lock the cable connector to the equipment connector, the threaded ring is tightened until it is 'finger-tight' (approx. 50 cNm).