

AN1393 (AN6914), AN1393S (AN6914S)

Dual Comparators

■ Overview

The AN1393 (AN6914) and the AN1393S (AN6914S) are dual (voltage) comparators with wide range of operating supply voltage.

■ Features

- Wide range of operating voltages
Single supply: 2 to 36V
Dual supply: ± 1 to ± 18 V
- Low circuit current: 0.6mA typ.
- Wide range of common-mode input voltages
: 0V to $V_{CC}-1.5$ V (single supply)
- Open collector output

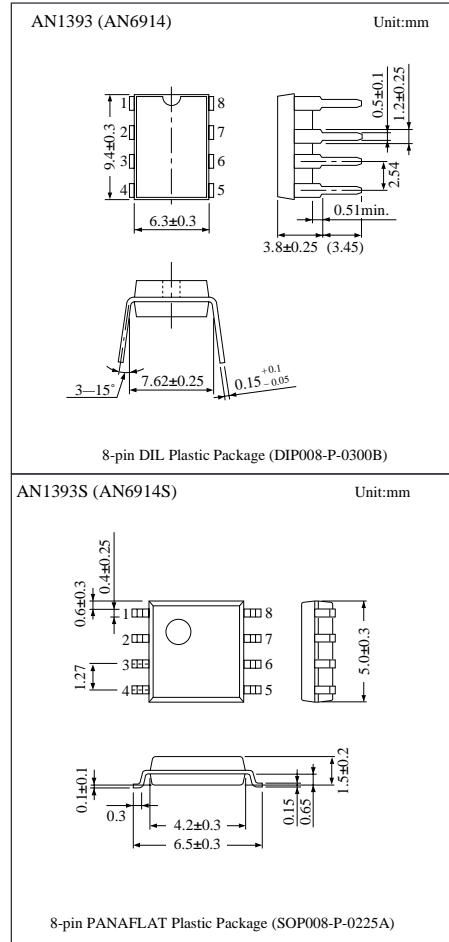

■ Block Diagram

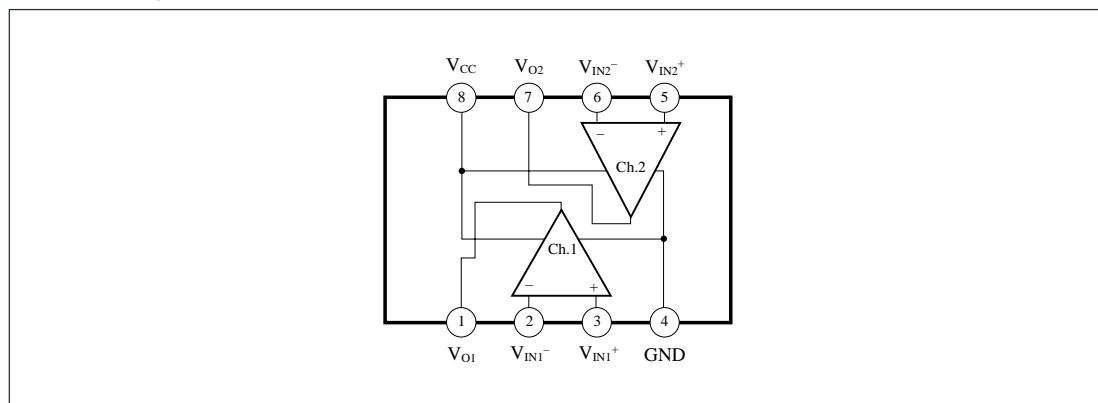

■ Pin Descriptions

Pin No.	Pin name
1	Ch.1 output
2	Ch.1 inverting input
3	Ch.1 non inverting input
4	GND
5	Ch.2 non inverting input
6	Ch.2 inverting input
7	Ch.2 output
8	V _{CC}

■ Absolute Maximum Ratings (Ta=25°C)

Parameter		Symbol	Rating	Unit
Voltage	Supply voltage	V _{CC}	36	V
	Common-mode input voltage	V _{ICM} *1	- 0.3 to 36	V
	Differential input voltage	V _{ID} *2	36	V
	Output applied voltage	V ₁ , V ₇	24	V
Power dissipation	AN1393 (AN6914)	P _D	500	mW
	AN1393S(AN6914S)		360	
Operating ambient temperature		T _{opr}	- 30 to +85	°C
Storage temperature	AN1393(AN6914)	T _{stg}	- 55 to +150	°C
	AN1393S(AN6914S)		- 55 to +125	

*1 The common mode input voltage is a voltage applied to the non-inverting input pin and inverting input pin simultaneously.

*2 Differential input is equivalent to the potential difference between the non-inverting input pin and inverting input pin.

■ Recommended Operating Range (Ta=25°C)

Parameter	Symbol	Range
Operating supply voltage range	V _{CC}	Single power supply 2V to 36V
		Double power supply ±1V to ±18V

■ Electrical Characteristics (V_{CC}=5V, Ta=25°C)

Parameter	Symbol	Condition	min	typ	max	Unit
Input offset voltage	V _{I(offset)}		—	1	5	mV
Input offset current	I _{IO}		—	—	50	nA
Input bias current	I _{Bias}		—	—	250	nA
Voltage gain	G _V	R _L =15kΩ	—	200	—	V/mV
Common-mode input voltage range	V _{CM}		0	—	V _{CC} -1.5	V
Supply current	I _{CC}	R _L =∞	—	0.6	1.5	mA
Response time	t _r	R _L =5.1kΩ, V _{RL} =5V	—	1.3	—	μs
Output sink current	I _{SINK}	V _{REF} =0V, V _{IN} =1V, V _O ≤1.5V	10	—	—	mA
Low level output voltage	V _{OL}	V _{REF} =0V, V _{IN} =1V, I _{SINK} =3mA	—	0.2	0.4	V
Output terminal leakage current	I _{O(Leak)}	V _{IN} =0V, V _{REF} =1V, V _O =5V	—	0.1	—	nA

■ Characteristics Curve

