

# AN7168

## Dual 5.8W Audio Power Amplifier Circuit

### ■ Overview

The AN7168 is an integrated circuit designed for low distortion, low noise and low power dissipation audio set of 5.8W (13.2V, 4Ω) output. Stereo operation is enabled due to incorporating two amplifiers on one chip. 12-pin SIL package enabled compact and high integrated set. Thermal protection, short protection and excessive protection circuits are built in.

### ■ Features

- Highly stable operation
- Low distortion
- Low quiescent current
- Low noise
- Low shock noise from power ON/OFF operation
- Built-in muting circuit
- Fewer external components
- Incorporating protection circuits

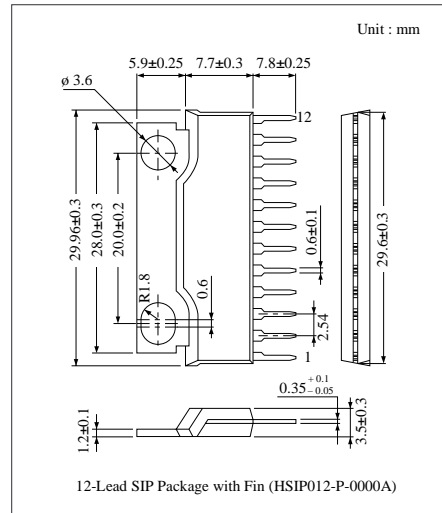

### ■ Pin Descriptions

Pin No.	Pin Name	Pin No.	Pin Name
1	NFB Ch.1	7	Output Ch.2
2	Input Ch.1	8	Bootstrap Ch.2
3	Ripple Filter	9	GND (Output)
4	GND (Input)	10	V <sub>CC</sub>
5	Input Ch.2	11	Bootstrap Ch.1
6	NFB Ch.2	12	Output Ch.1

### ■ Block Diagram

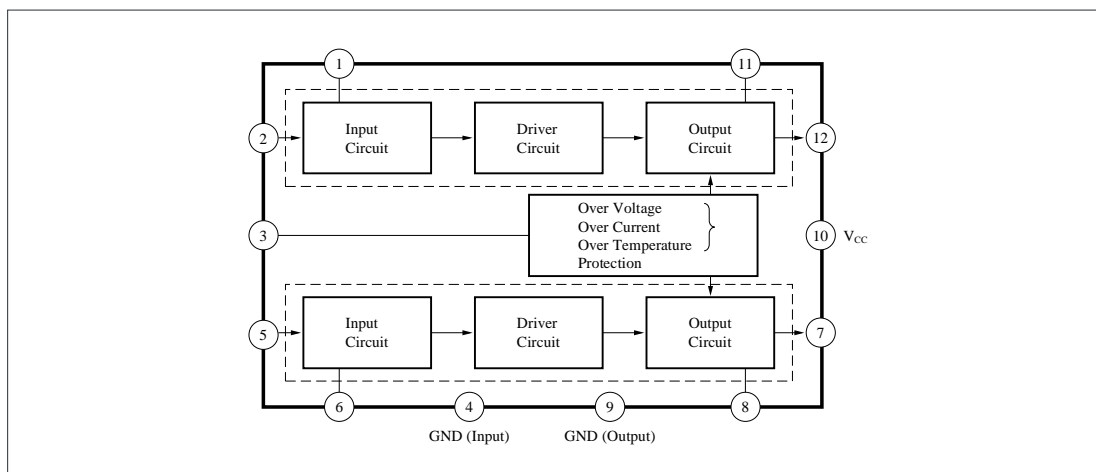

### ■ Absolute Maximum Ratings (Ta= 25°C)

Parameter	Symbol	Rating	Unit
Supply Voltage	V <sub>CC</sub>	24	V
Supply Current	I <sub>CC</sub>	4	A
Power Dissipation <sup>Note 1)</sup>	P <sub>D</sub>	41.7	W
Peak Supply Voltage <sup>Note 2)</sup>	V <sub>CC(surge)</sub>	50	V
Operating Ambient Temperature	T <sub>opr</sub>	- 30 ~ + 75	°C
Storage Temperature	T <sub>stg</sub>	- 55 ~ + 150	°C

Note 1)  $R_{\theta j-c} = 3^{\circ}\text{C/W}$

Note 2) Voltage applied time = 0.2s

### ■ Electrical Characteristics (V<sub>CC</sub>= 13.2V, f = 1kHz, R<sub>L</sub>= 4Ω, Ta= 25°C)

Parameter	Symbol	Condition	min.	typ.	max.	Unit
Quiescent Circuit Current	I <sub>CQ</sub>	V <sub>i</sub> = 0mV	30	55	100	mA
Voltage Gain	G <sub>V</sub>	P <sub>O</sub> = 0.5W	52	54	56	dB
Total Harmonic Distortion	THD	P <sub>O</sub> = 0.5W, f= 1kHz	—	0.1	0.5	%
		P <sub>O</sub> = 0.5W, f= 100Hz	—	0.1	—	
		P <sub>O</sub> = 0.5W, f= 10kHz	—	0.2	—	
Maximum Output	P <sub>O</sub>	THD = 10%	5	5.7	—	W
		THD = 10%, R <sub>L</sub> = 2Ω	—	8.9	—	
		THD = 10%, R <sub>L</sub> = 8Ω	—	3.1	—	
Output Noise Voltage	V <sub>no</sub>	R <sub>g</sub> = 10kΩ, 1000pF f = 15Hz ~ 30kHz, 12dB/OCT	—	0.8	1.5	mV
		R <sub>g</sub> = 10kΩ, 1000pF, Without Filter	—	1.1	—	
Channel Balance	CB	P <sub>O</sub> = 0.5W	—	0	1	dB
Channel Separation	CS	P <sub>O</sub> = 0.5W	40	50	—	dB
Ripple Rejection Ratio	RR	P <sub>O</sub> = 0.5W, R <sub>g</sub> = 10kΩ, V <sub>ripple</sub> = 280mVrms, f <sub>ripple</sub> = 12Hz Sine wave	35	45	—	dB
Offset Voltage	V <sub>O(offset)</sub>	V <sub>i</sub> = 0mV	—	0	200	mV

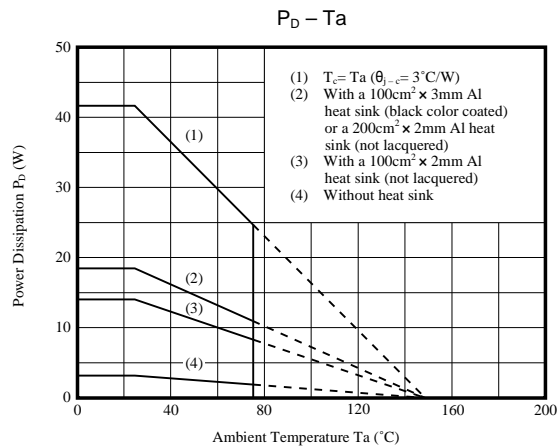

■ Application Circuit

