

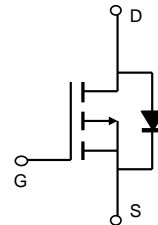
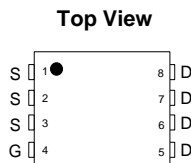
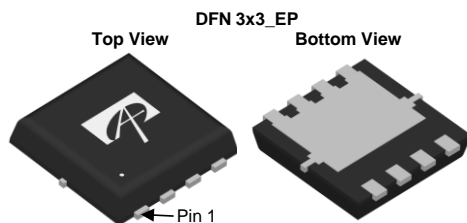
### General Description

The AON7401 uses advanced trench technology to provide excellent  $R_{DS(ON)}$ , and ultra-low low gate charge with a 25V gate rating. This device is suitable for use as a load switch or in PWM applications.

### Product Summary

|                                  |                |
|----------------------------------|----------------|
| $V_{DS}$                         | -30V           |
| $I_D$ (at $V_{GS}=-10V$ )        | -35A           |
| $R_{DS(ON)}$ (at $V_{GS}=-10V$ ) | < 14m $\Omega$ |
| $R_{DS(ON)}$ (at $V_{GS}=-6V$ )  | < 17m $\Omega$ |

100% UIS Tested  
 100%  $R_g$  Tested



### Absolute Maximum Ratings $T_A=25^\circ\text{C}$ unless otherwise noted

| Parameter                              | Symbol         | Maximum                 | Units            |
|--|----------------|-------------------------|------------------|
| Drain-Source Voltage                   | $V_{DS}$       | -30                     | V                |
| Gate-Source Voltage                    | $V_{GS}$       | $\pm 25$                | V                |
| Continuous Drain Current               | $I_D$          | $T_C=25^\circ\text{C}$  | -35              |
|  |                | $T_C=100^\circ\text{C}$ | -23              |
| Pulsed Drain Current <sup>C</sup>      | $I_{DM}$       | -80                     | A                |
| Continuous Drain Current               | $I_{DSM}$      | $T_A=25^\circ\text{C}$  | -12              |
|  |                | $T_A=70^\circ\text{C}$  | -9.7             |
| Power Dissipation <sup>B</sup>         | $P_D$          | $T_C=25^\circ\text{C}$  | 29               |
|  |                | $T_C=100^\circ\text{C}$ | 12               |
| Power Dissipation <sup>A</sup>         | $P_{DSM}$      | $T_A=25^\circ\text{C}$  | 3.1              |
|  |                | $T_A=70^\circ\text{C}$  | 2                |
| Junction and Storage Temperature Range | $T_J, T_{STG}$ | -55 to 150              | $^\circ\text{C}$ |

### Thermal Characteristics

| Parameter                                  | Symbol          | Typ | Max | Units              |
|--|-----------------|-----|-----|--------------------|
| Maximum Junction-to-Ambient <sup>A</sup>   | $R_{\theta JA}$ | 30  | 40  | $^\circ\text{C/W}$ |
| Maximum Junction-to-Ambient <sup>A D</sup> |                 | 60  | 75  | $^\circ\text{C/W}$ |
| Maximum Junction-to-Lead                   | $R_{\theta JL}$ | 3.5 | 4.2 | $^\circ\text{C/W}$ |

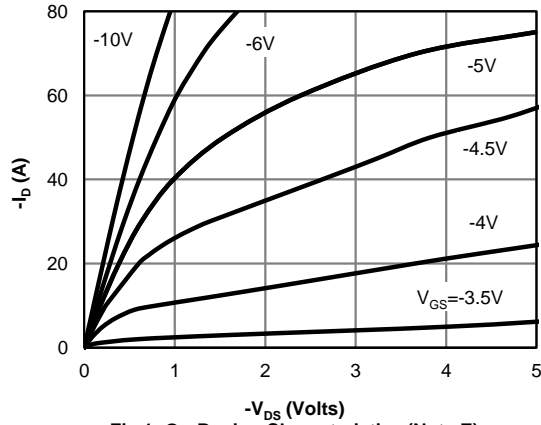
**Electrical Characteristics (T<sub>J</sub>=25°C unless otherwise noted)**

| Symbol                      | Parameter                             | Conditions  | Min                                | Typ      | Max      | Units |
|-----------------------------|---------------------------------------|---|------------------------------------|----------|----------|-------|
| <b>STATIC PARAMETERS</b>    |                                       |   |                                    |          |          |       |
| BV <sub>DSS</sub>           | Drain-Source Breakdown Voltage        | I <sub>D</sub> =-250μA, V <sub>GS</sub> =0V   | -30                                |          |          | V     |
| I <sub>DSS</sub>            | Zero Gate Voltage Drain Current       | V <sub>DS</sub> =-30V, V <sub>GS</sub> =0V<br>T <sub>J</sub> =55°C                          |                                    |          | -1<br>-5 | μA    |
| I <sub>GSS</sub>            | Gate-Body leakage current             | V <sub>DS</sub> =0V, V <sub>GS</sub> = ±25V   |                                    |          | ±100     | nA    |
| V <sub>GS(th)</sub>         | Gate Threshold Voltage                | V <sub>DS</sub> =V <sub>GS</sub> I <sub>D</sub> =-250μA                                     | -1.7                               | -2.2     | -3       | V     |
| I <sub>D(ON)</sub>          | On state drain current                | V <sub>GS</sub> =-10V, V <sub>DS</sub> =-5V   | -80                                |          |          | A     |
| R <sub>DS(ON)</sub>         | Static Drain-Source On-Resistance     | V <sub>GS</sub> =-10V, I <sub>D</sub> =-9A<br>T <sub>J</sub> =125°C                         |                                    | 11<br>16 | 14<br>19 | mΩ    |
|                             |                                       | V <sub>GS</sub> =-6V, I <sub>D</sub> =-7A   |                                    | 12.9     | 17       | mΩ    |
| g <sub>FS</sub>             | Forward Transconductance              | V <sub>DS</sub> =-5V, I <sub>D</sub> =-9A   |                                    | 27       |          | S     |
| V <sub>SD</sub>             | Diode Forward Voltage                 | I <sub>S</sub> =-1A, V <sub>GS</sub> =0V  |                                    | -0.7     | -1       | V     |
| I <sub>S</sub>              | Maximum Body-Diode Continuous Current |   |                                    |          | -25      | A     |
| <b>DYNAMIC PARAMETERS</b>   |                                       |   |                                    |          |          |       |
| C <sub>iss</sub>            | Input Capacitance                     | V <sub>GS</sub> =0V, V <sub>DS</sub> =-15V, f=1MHz  |                                    | 2060     | 2600     | pF    |
| C <sub>oss</sub>            | Output Capacitance                    |   |                                    | 370      |          | pF    |
| C <sub>riss</sub>           | Reverse Transfer Capacitance          |   |                                    | 295      |          | pF    |
| R <sub>g</sub>              | Gate resistance                       | V <sub>GS</sub> =0V, V <sub>DS</sub> =0V, f=1MHz  |                                    | 2.4      | 3.6      | Ω     |
| <b>SWITCHING PARAMETERS</b> |                                       |   |                                    |          |          |       |
| Q <sub>g(10V)</sub>         | Total Gate Charge                     | V <sub>GS</sub> =-10V, V <sub>DS</sub> =-15V, I <sub>D</sub> =-9A                           |                                    | 30       | 39       | nC    |
| Q <sub>gs</sub>             | Gate Source Charge                    |   |                                    | 4.6      |          | nC    |
| Q <sub>gd</sub>             | Gate Drain Charge                     |   |                                    | 10       |          | nC    |
| t <sub>D(on)</sub>          | Turn-On DelayTime                     | V <sub>GS</sub> =-10V, V <sub>DS</sub> =-15V, R <sub>L</sub> =1.6Ω,<br>R <sub>GEN</sub> =3Ω |                                    | 11       |          | ns    |
| t <sub>r</sub>              | Turn-On Rise Time                     |   |                                    | 9.4      |          | ns    |
| t <sub>D(off)</sub>         | Turn-Off DelayTime                    |   |                                    | 24       |          | ns    |
| t <sub>f</sub>              | Turn-Off Fall Time                    |   |                                    | 12       |          | ns    |
| t <sub>rr</sub>             | Body Diode Reverse Recovery Time      |   | I <sub>F</sub> =-9A, di/dt=500A/μs |          | 14       | 18    |
| Q <sub>rr</sub>             | Body Diode Reverse Recovery Charge    | I <sub>F</sub> =-9A, di/dt=500A/μs  |                                    | 35       |          | nC    |

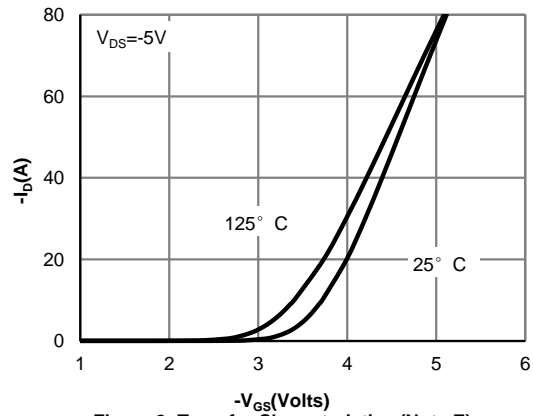
- A. The value of R<sub>θJA</sub> is measured with the device mounted on 1in<sup>2</sup> FR-4 board with 2oz. Copper, in a still air environment with T<sub>A</sub>=25° C. The Power dissipation P<sub>DSM</sub> is based on R<sub>θJA</sub> t ≤ 10s value and the maximum allowed junction temperature of 150° C. The value in any given application depends on the user's specific board design, and the maximum temperature of 150° C may be used if the PCB allows it.
- B. The power dissipation P<sub>D</sub> is based on T<sub>J(MAX)</sub>=150° C, using junction-to-case thermal resistance, and is more useful in setting the upper dissipation limit for cases where additional heatsinking is used.
- C. Repetitive rating, pulse width limited by junction temperature T<sub>J(MAX)</sub>=150° C. Ratings are based on low frequency and duty cycles to keep initial T<sub>J</sub>=25° C.
- D. The R<sub>θJA</sub> is the sum of the thermal impedance from junction to case R<sub>θJC</sub> and case to ambient.
- E. The static characteristics in Figures 1 to 6 are obtained using <300μs pulses, duty cycle 0.5% max.
- F. These curves are based on the junction-to-case thermal impedance which is measured with the device mounted to a large heatsirk, assuming a maximum junction temperature of T<sub>J(MAX)</sub>=150° C. The SOA curve provides a single pulse rating.
- G. The maximum current rating is package limited.
- H. These tests are performed with the device mounted on 1 in<sup>2</sup> FR-4 board with 2oz. Copper, in a still air environment with T<sub>A</sub>=25° C.

THIS PRODUCT HAS BEEN DESIGNED AND QUALIFIED FOR THE CONSUMER MARKET. APPLICATIONS OR USES AS CRITICAL COMPONENTS IN LIFE SUPPORT DEVICES OR SYSTEMS ARE NOT AUTHORIZED. AOS DOES NOT ASSUME ANY LIABILITY ARISING OUT OF SUCH APPLICATIONS OR USES OF ITS PRODUCTS. AOS RESERVES THE RIGHT TO IMPROVE PRODUCT DESIGN, FUNCTIONS AND RELIABILITY WITHOUT NOTICE.

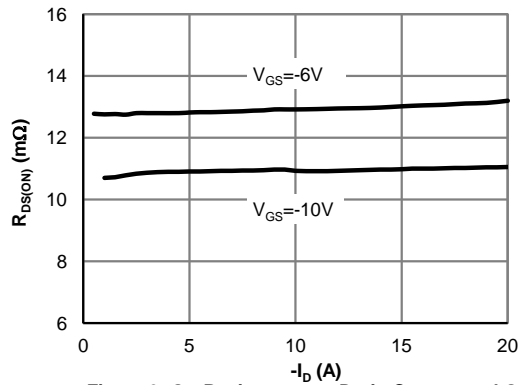
**TYPICAL ELECTRICAL AND THERMAL CHARACTERISTICS**



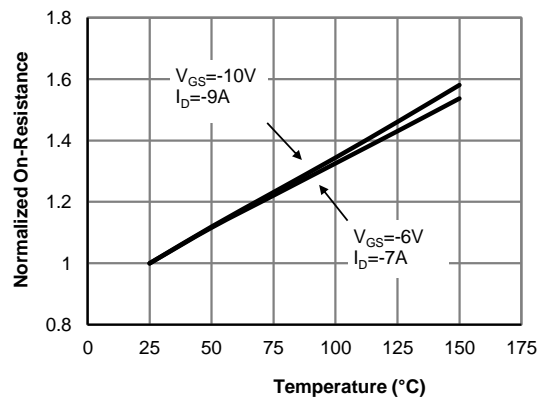
**Fig 1: On-Region Characteristics (Note E)**



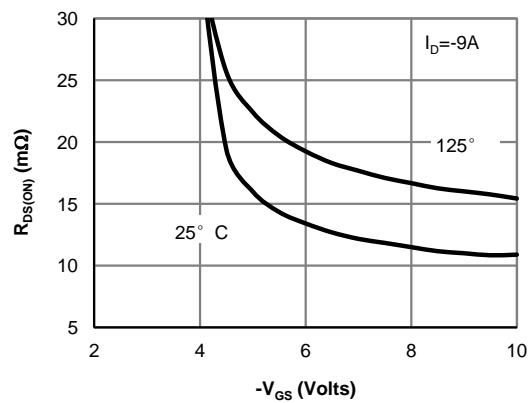
**Figure 2: Transfer Characteristics (Note E)**



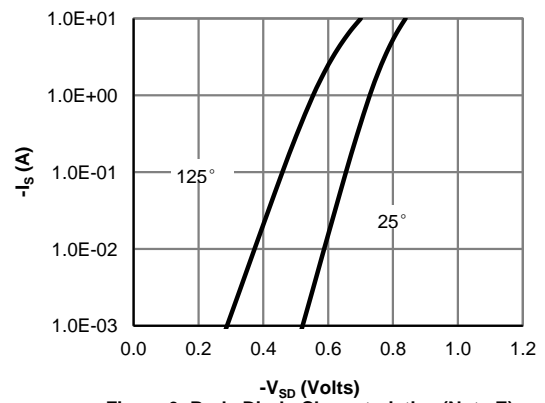
**Figure 3: On-Resistance vs. Drain Current and Gate Voltage (Note E)**



**Figure 4: On-Resistance vs. Junction Temperature (Note E)**

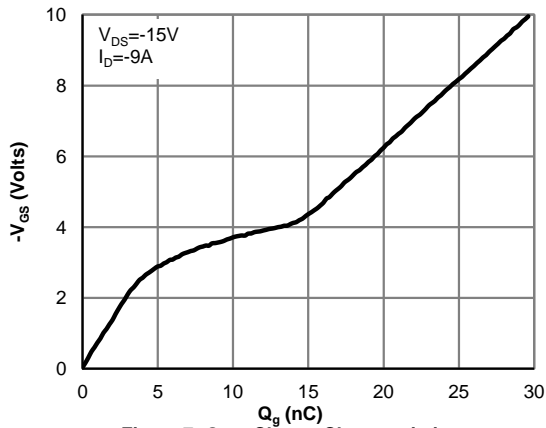


**Figure 5: On-Resistance vs. Gate-Source Voltage (Note E)**

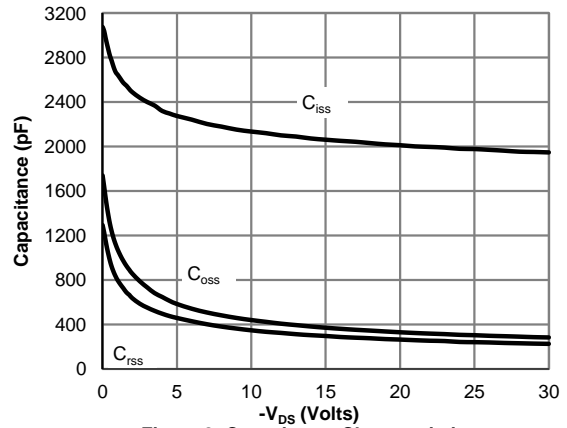


**Figure 6: Body-Diode Characteristics (Note E)**

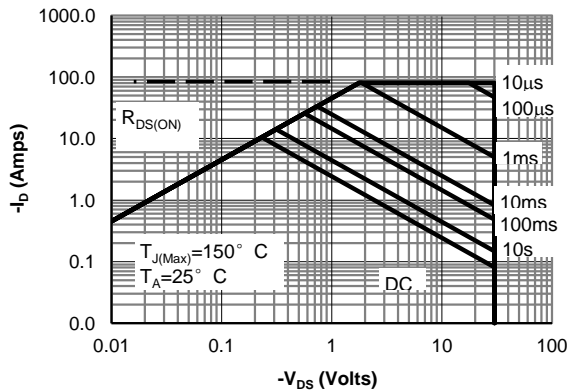
**TYPICAL ELECTRICAL AND THERMAL CHARACTERISTICS**



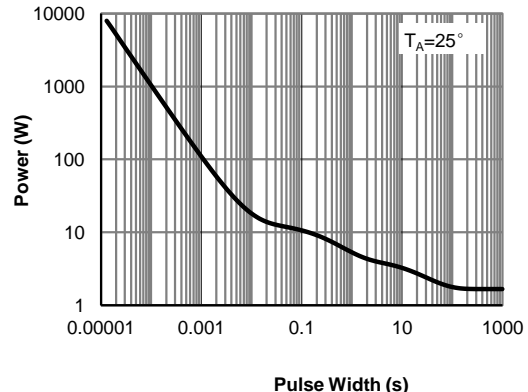
**Figure 7: Gate-Charge Characteristics**



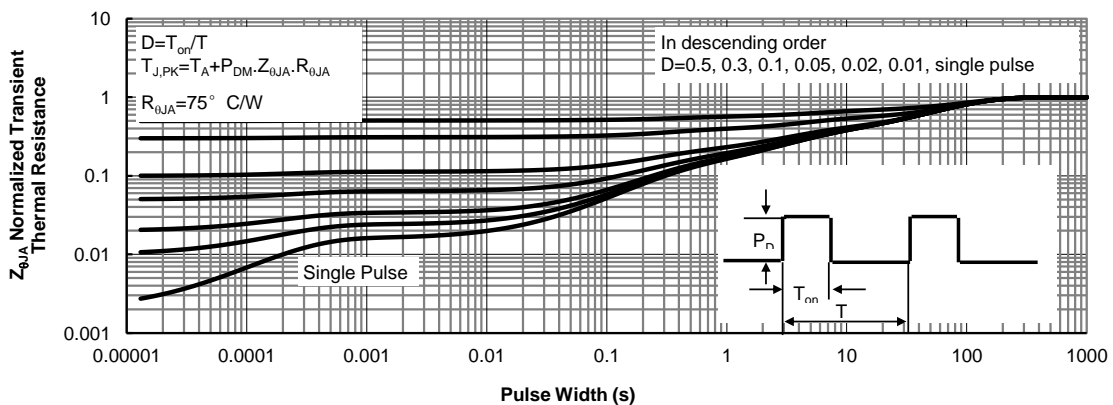
**Figure 8: Capacitance Characteristics**



**Figure 9: Maximum Forward Biased Safe Operating Area (Note F)**

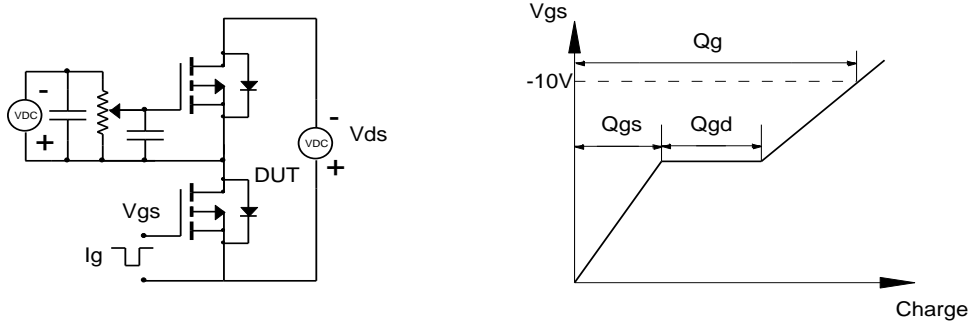


**Figure 10: Single Pulse Power Rating Junction-to-Ambient (Note F)**

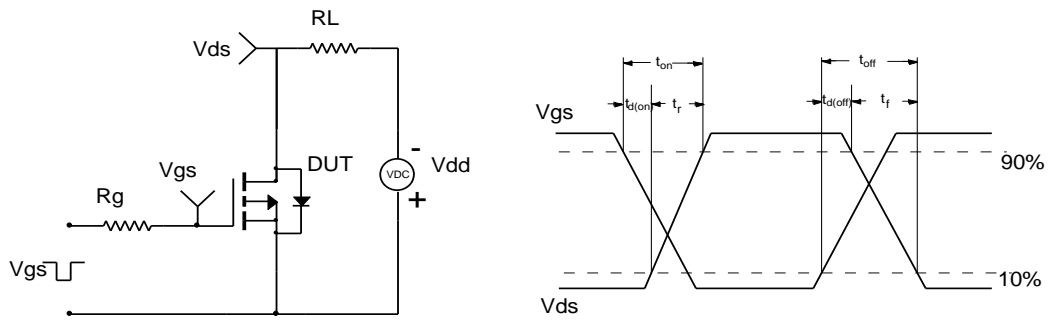


**Figure 11: Normalized Maximum Transient Thermal Impedance (Note F)**

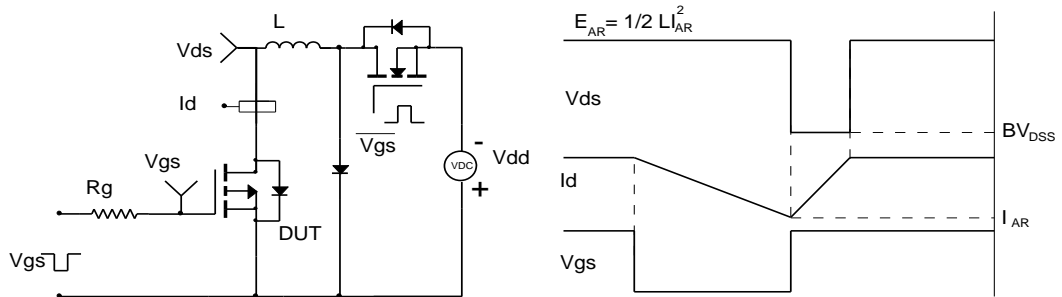
**Gate Charge Test Circuit & Waveform**



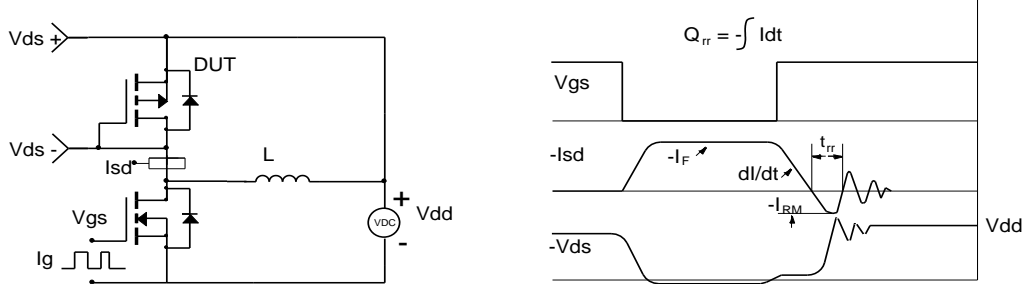
**Resistive Switching Test Circuit & Waveforms**



**Unclamped Inductive Switching (UIS) Test Circuit & Waveforms**



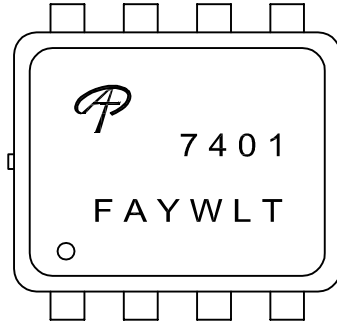
**Diode Recovery Test Circuit & Waveforms**





|              |                             |
|--------------|-----------------------------|
| Document No. | PD-00873                    |
| Version      | B                           |
| Title        | AON7401 Marking Description |

DFN3X3 PACKAGE MARKING DESCRIPTION



Green product

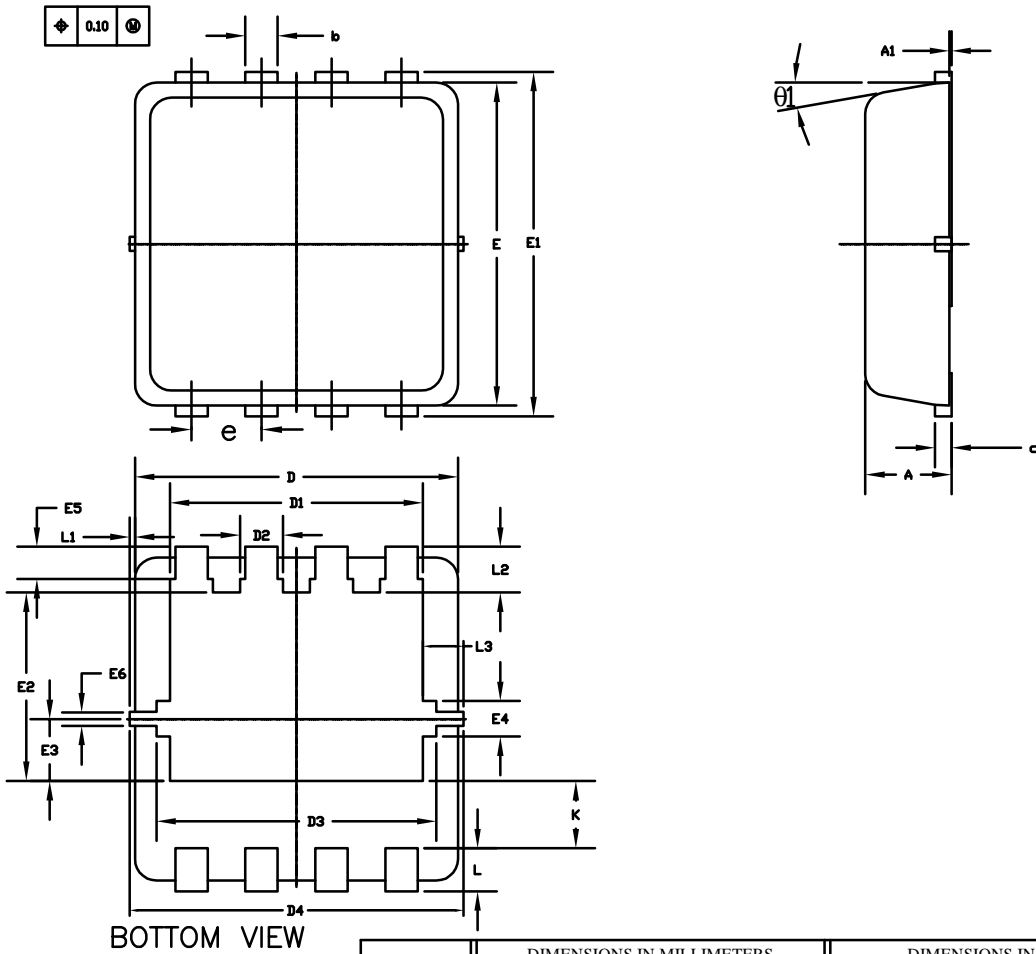
NOTE:

- LOGO - AOS Logo
- 7401 - Part number code
- F - Fab code
- A - Assembly location code
- Y - Year code
- W - Week code
- L&T - Assembly lot code

| PART NO. | DESCRIPTION   | CODE |
|----------|---------------|------|
| AON7401  | Green product | 7401 |
| AON7401L | Green product | 7401 |

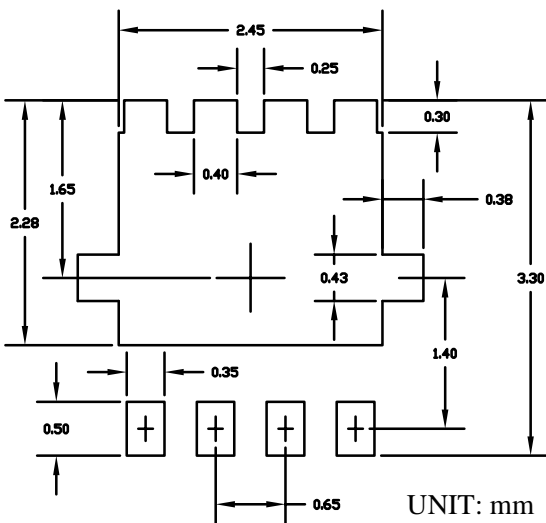


DFN3x3A\_8L\_EP1\_P PACKAGE OUTLINE



BOTTOM VIEW

RECOMMENDED LAND PATTERN



UNIT: mm

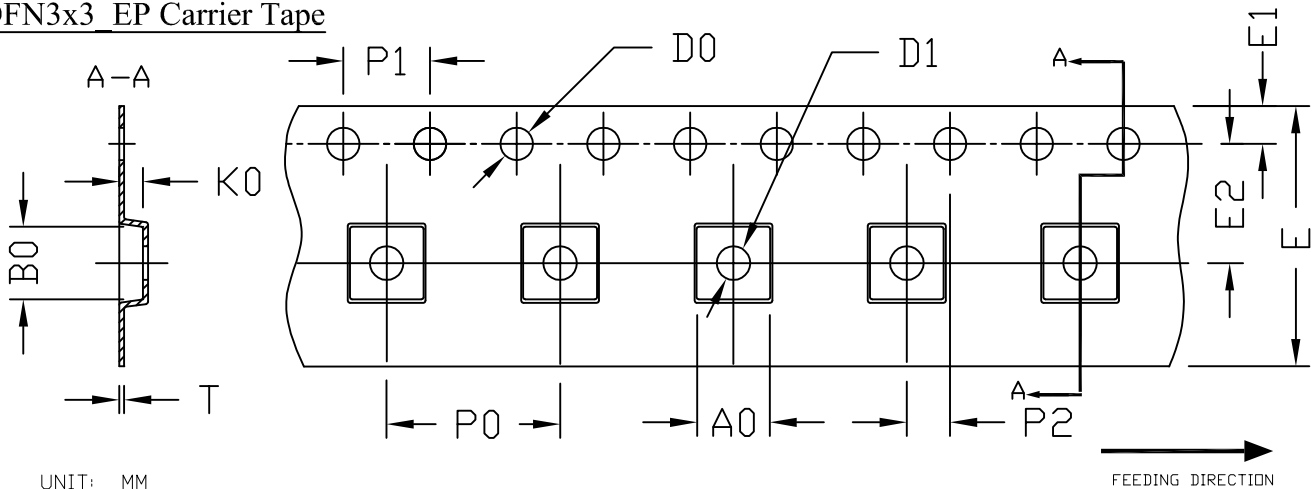
| SYMBOLS | DIMENSIONS IN MILLIMETERS |       |       | DIMENSIONS IN INCHES |       |       |
|---------|---------------------------|-------|-------|----------------------|-------|-------|
|         | MIN                       | NOM   | MAX   | MIN                  | NOM   | MAX   |
| A       | 0.70                      | 0.80  | 0.90  | 0.028                | 0.031 | 0.035 |
| A1      | 0.00                      | 0.025 | 0.05  | 0.000                | 0.001 | 0.002 |
| b       | 0.24                      | 0.30  | 0.35  | 0.009                | 0.012 | 0.014 |
| c       | 0.10                      | 0.15  | 0.25  | 0.004                | 0.006 | 0.010 |
| D       | 2.90                      | 3.00  | 3.10  | 0.114                | 0.118 | 0.122 |
| D1      | 2.25                      | 2.35  | 2.45  | 0.089                | 0.093 | 0.097 |
| D2      | 0.30                      | 0.40  | 0.50  | 0.012                | 0.016 | 0.020 |
| D3      | 2.50                      | 2.60  | 2.70  | 0.098                | 0.102 | 0.106 |
| D4      | 3.00                      | 3.10  | 3.20  | 0.118                | 0.122 | 0.126 |
| E       | 2.90                      | 3.00  | 3.10  | 0.114                | 0.118 | 0.122 |
| E1      | 3.10                      | 3.20  | 3.30  | 0.122                | 0.126 | 0.130 |
| E2      | 1.65                      | 1.75  | 1.85  | 0.065                | 0.069 | 0.073 |
| E3      | 0.48                      | 0.58  | 0.68  | 0.019                | 0.023 | 0.027 |
| E4      | 0.23                      | 0.33  | 0.43  | 0.009                | 0.013 | 0.017 |
| E5      | 0.20                      | 0.30  | 0.40  | 0.008                | 0.012 | 0.016 |
| E6      | 0.075                     | 0.125 | 0.175 | 0.003                | 0.005 | 0.007 |
| e       | 0.60                      | 0.65  | 0.70  | 0.024                | 0.026 | 0.028 |
| K       | 0.52                      | 0.62  | 0.72  | 0.020                | 0.024 | 0.028 |
| L       | 0.30                      | 0.40  | 0.50  | 0.012                | 0.016 | 0.020 |
| L1      | 0                         | 0.05  | 0.10  | 0                    | 0.002 | 0.004 |
| L2      | 0.33                      | 0.43  | 0.53  | 0.013                | 0.017 | 0.021 |
| L3      | 0.275                     | 0.375 | 0.475 | 0.011                | 0.015 | 0.019 |
| theta 1 | 0°                        | 10°   | 12°   | 0°                   | 10°   | 12°   |

NOTE

1. PACKAGE DIMENSION IS EXCLUSIVE OF MOLD GATE BURR
2. PACKAGE DIMENSION IS EXCLUSIVE OF MOLD FLASH AND CUTTING BURR
3. CONTROLLING DIMENSION IS MILLIMETER.  
CONVERTED INCH DIMENSIONS ARE NOT NECESSARILY EXACT.



DFN3x3 EP Carrier Tape

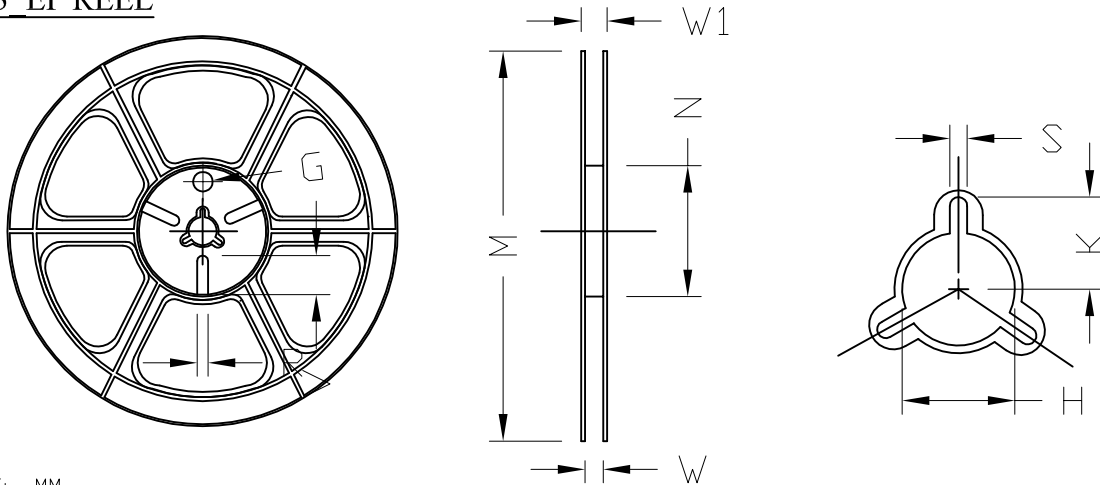


UNIT: MM

FEEDING DIRECTION

| PACKAGE   | A0            | B0            | K0            | D0                  | D1                  | E              | E1            | E2            | P0            | P1            | P2            | T             |
|-----------|---------------|---------------|---------------|---------------------|---------------------|----------------|---------------|---------------|---------------|---------------|---------------|---------------|
| DFN3x3_EP | 3.40<br>±0.10 | 3.35<br>±0.10 | 1.10<br>±0.10 | 1.50<br>+0.10<br>-0 | 1.50<br>+0.10<br>-0 | 12.00<br>±0.30 | 1.75<br>±0.10 | 5.50<br>±0.05 | 8.00<br>±0.10 | 4.00<br>±0.10 | 2.00<br>±0.05 | 0.30<br>±0.05 |

DFN3x3 EP REEL



UNIT: MM

| TAPE SIZE | REEL SIZE | M                | N               | W              | W1             | H                        | K     | S             | G   | R   | V   |
|-----------|-----------|------------------|-----------------|----------------|----------------|--------------------------|-------|---------------|-----|-----|-----|
| 12 mm     | ∅330      | ∅330.00<br>±0.50 | ∅97.00<br>±0.10 | 13.00<br>±0.30 | 17.40<br>±1.00 | ∅13.00<br>+0.50<br>-0.20 | 10.60 | 2.00<br>±0.50 | --- | --- | --- |



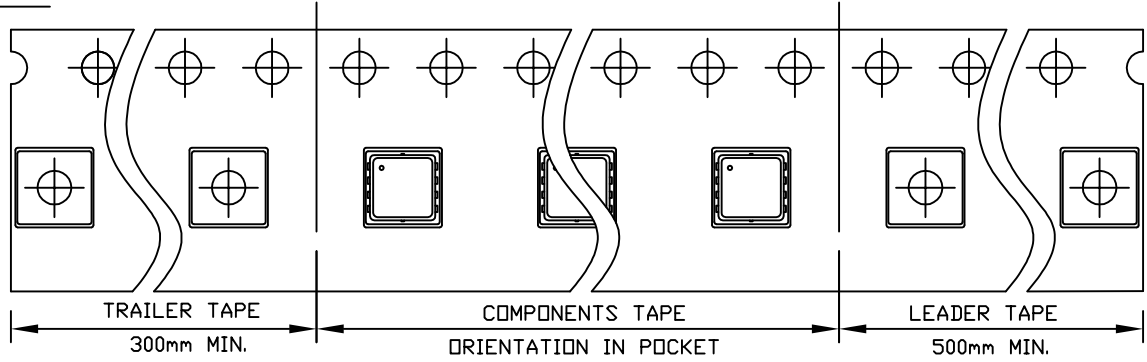


**DFN3x3 EP TAPE**

Leader / Trailer  
& Orientation

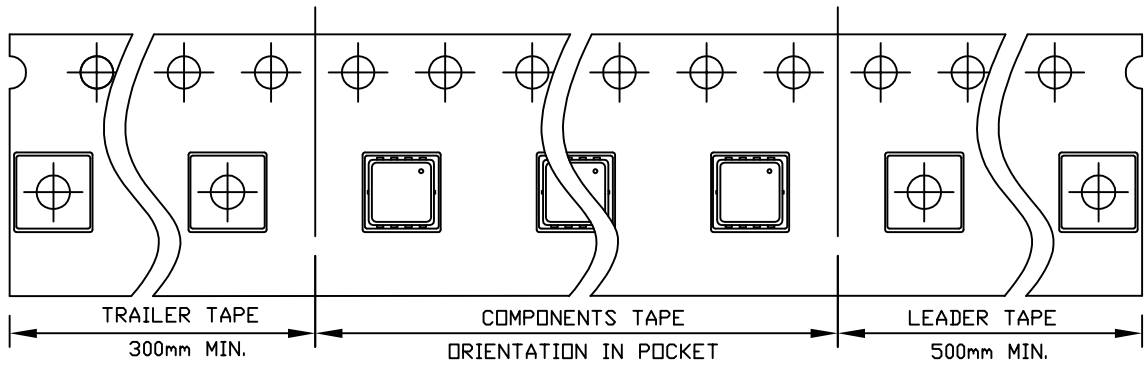
MOS

Unit Per Reel:  
5000pcs



PIC

Unit Per Reel:  
5000pcs





# ***AOS Semiconductor Product Reliability Report***

**AON7401, rev C**

**Plastic Encapsulated Device**

**ALPHA & OMEGA Semiconductor, Inc**

**[www.aosmd.com](http://www.aosmd.com)**



This AOS product reliability report summarizes the qualification result for AON7401. Accelerated environmental tests are performed on a specific sample size, and then followed by electrical test at end point. Review of final electrical test result confirms that AON7401 passes AOS quality and reliability requirements.

## Table of Contents:

- I. Product Description
- II. Package and Die information
- III. Environmental Stress Test Summary and Result
- IV. Reliability Evaluation

## I. Product Description:

The AON7401 uses advanced trench technology to provide excellent  $R_{DS(ON)}$ , and ultra-low low gate charge with a 25V gate rating. This device is suitable for use as a load switch or in PWM applications.

- RoHS Compliant
- Halogen-Free

Detailed information refers to datasheet.

## II. Die / Package Information:

|                                       | <b>AON7401</b>                               |
|---------------------------------------|--|
| <b>Process</b>                        | Standard sub-micron<br>Low voltage P channel |
| <b>Package Type</b>                   | DFN 3x3A                                     |
| <b>Lead Frame</b>                     | Cu   |
| <b>Die Attach</b>                     | Ag epoxy                                     |
| <b>Bonding</b>                        | Cu wire                                      |
| <b>Mold Material</b>                  | Epoxy resin with silica filler               |
| <b>MSL (moisture sensitive level)</b> | Level 1 based on J-STD-020                   |

**Note** \* based on information provided by assembler and mold compound supplier

### III. Result of Reliability Stress for AON7401

| Test Item         | Test Condition                                | Time Point                   | Lot Attribution              | Total Sample size     | Number of Failures | Standard    |
|-------------------|---|------------------------------|------------------------------|-----------------------|--------------------|-------------|
| MSL Precondition  | 168hr 85°C /85%RH +3 cycle reflow@260°C       | -                            | 11 lots                      | 2299pcs               | 0                  | JESD22-A113 |
| HTGB              | Temp = 150 °c, Vgs=100% of Vgsmax             | 168hrs<br>500hrs<br>1000 hrs | 1 lot<br>3 lots<br>(Note A*) | 308pcs<br>77pcs / lot | 0                  | JESD22-A108 |
| HTRB              | Temp = 150 °c, Vds=80% of Vdsmax              | 168hrs<br>500hrs<br>1000 hrs | 1 lot<br>3 lots<br>(Note A*) | 308pcs<br>77pcs / lot | 0                  | JESD22-A108 |
| HAST              | 130°C, 85%RH, 33.3 psi, Vgs = 100% of Vgs max | 100 hrs                      | 11 lots<br>(Note A*)         | 605pcs<br>55pcs / lot | 0                  | JESD22-A110 |
| Pressure Pot      | 121°C, 29.7psi, RH=100%                       | 96 hrs                       | 11 lots<br>(Note A*)         | 847pcs<br>77pcs / lot | 0                  | JESD22-A102 |
| Temperature Cycle | -65°C to 150°C, air to air                    | 250 / 500 cycles             | 11 lots<br>(Note A*)         | 847pcs<br>77pcs / lot | 0                  | JESD22-A104 |

**Note A:** The reliability data presents total of available generic data up to the published date.

### IV. Reliability Evaluation

**FIT rate (per billion): 7**  
**MTTF = 15704 years**

The presentation of FIT rate for the individual product reliability is restricted by the actual burn-in sample size of the selected product (AON7401). Failure Rate Determination is based on JEDEC Standard JESD 85. FIT means one failure per billion hours.

$$\text{Failure Rate} = \text{Chi}^2 \times 10^9 / [2 (N) (H) (Af)]$$

$$= 1.83 \times 10^9 / [2 \times (2 \times 77 \times 168 + 6 \times 77 \times 1000) \times 258] = 7$$

$$\text{MTTF} = 10^9 / \text{FIT} = 1.38 \times 10^8 \text{hrs} = 15704 \text{ years}$$

**Chi<sup>2</sup>** = Chi Squared Distribution, determined by the number of failures and confidence interval

**N** = Total Number of units from HTRB and HTGB tests

**H** = Duration of HTRB/HTGB testing

**Af** = Acceleration Factor from Test to Use Conditions (Ea = 0.7eV and Tuse = 55°C)

Acceleration Factor [Af] = **Exp** [Ea / k (1/Tj u - 1/Tj s)]

**Acceleration Factor ratio list:**

|    | 55 deg C | 70 deg C | 85 deg C | 100 deg C | 115 deg C | 130 deg C | 150 deg C |
|----|----------|----------|----------|-----------|-----------|-----------|-----------|
| Af | 258      | 87       | 32       | 13        | 5.64      | 2.59      | 1         |

**Tj s** = Stressed junction temperature in degree (Kelvin), K = C+273.16

**Tj u** = The use junction temperature in degree (Kelvin), K = C+273.16

**K** = Boltzmann's constant, 8.617164 X 10<sup>-5</sup>eV / K