

Characteristics

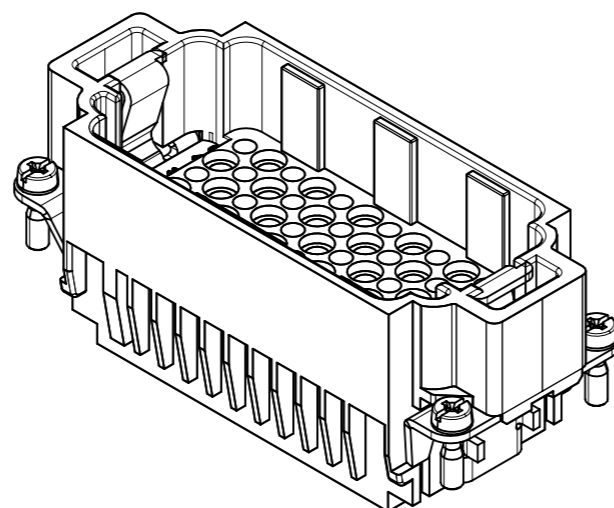
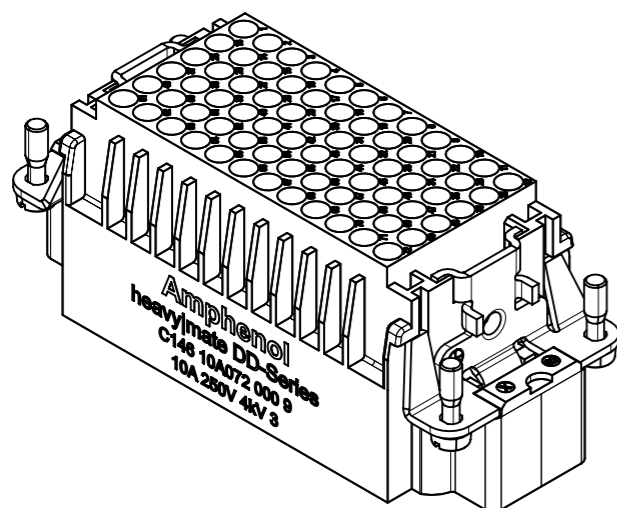
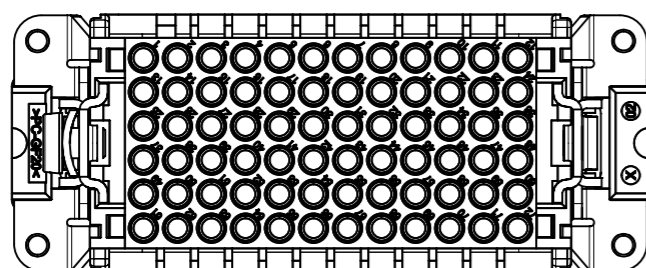
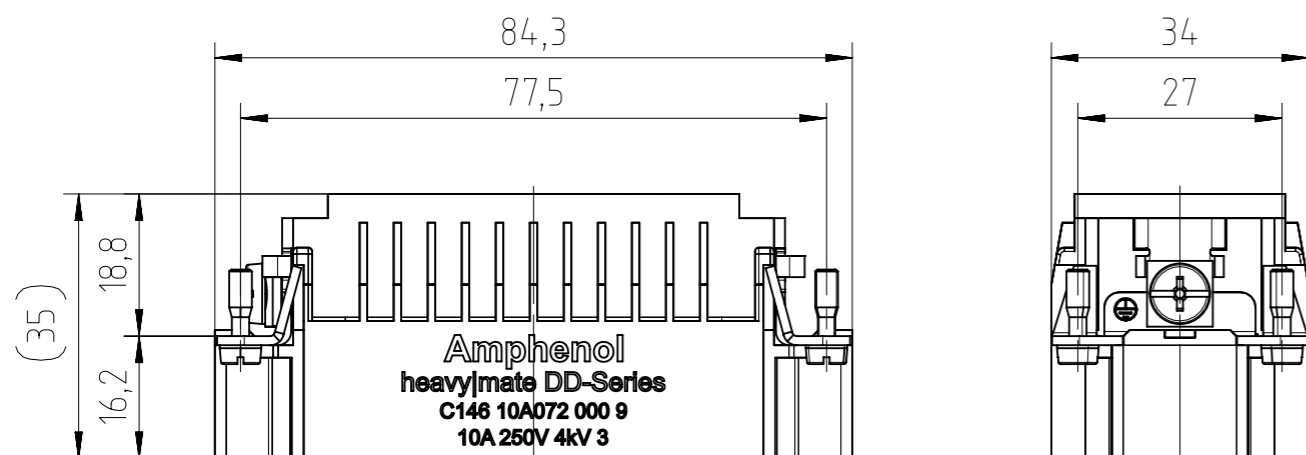

General Characteristics	Standard	Value
number of contacts		72
termination technique		crimp
wire gauge		0,14 mm ² - 2,5 mm ² AWG 26 - AWG 14
max. insulation diameter		3,7 mm
flammability	UL 94	V-0
Electrical Characteristics	Standard	Value
rated voltage	IEC 60664-1	250 V
pollution degree	IEC 60664-1	3
installation (overvoltage) category	IEC 60664-1	3
material group	IEC 60664-1	3b
rated impulse withstand voltage	IEC 60664-1	4 kV
rated current T _{amb} = 40 °C		10 A
current carrying capacity	IEC 60512-5-2	see derating curve
contact resistance	IEC 60512-2-1	≤ 5 mΩ
insulation resistance	IEC 60512-3-1	≥ 10 ¹⁰ Ω
Climatical Characteristics	Standard	Value
climatic category	IEC 60068-1	40 / 125 / 21
upper temperature	IEC 60512-11-9	+125 °C
lower temperature	IEC 60512-11-10	-40 °C
Mechanical Characteristics	Standard	Value
mechanical operation	IEC 60512-9-1	≥500 mating cycles
Materials	Standard	Value
insert		PC-GF20
contacts		CuZn (brass)
contact plating		Ag (silver)/Au (gold)
color		grey

Gewicht (errechnet) / Calc WT: 66,4 g		Zul. Abw./Tolerances:		Maßstab / Scale: 1:1		A3	
Prüfmaß / Testdimension		ISO 2768-m		DIN / ISO 13715		CUSTOMER DRAWING	
Teileindex / Partindexnumber:		Gez. 09.09.2015		Drawn JHOENNIGE2		Stifteinsatz 72-Pol	
Bagatelle change:		Status Released		Gepr. 13.08.2019		pin insert 72 pole	
		Checked MGRIMM		Amphenol Tuchel Industrial GmbH		Blatt / Sheet 1	
06	201900214	27.05.2019	PWÖLF			M C146 10A072 000 9	
05	201700119	02.05.2017	MTOLK			1 Bl.	
04	201600106	23.02.2016	JHÖNN				
03	201500015	09.09.2015	JHÖNN				
Index	Änderung / Description	Datum / Date	Name	Ers. f. / Replacement for: M-C146 10A072 000 9 Rev04		NXM-V04	

Alle technischen Daten wurden unter Laborbedingungen ermittelt und können im Praxisbetrieb abweichen. Es handelt sich bei den Angaben weder um Beschaffenheits- noch um Haltbarkeitsgarantien. All technical data have been measured in a laboratory environment and can be different during practical usage of the product. Any product information is for descriptive usage only and not legally binding; particularly the information does not constitute or provide any legal guarantees ("Beschaffenheitsgarantie" or "Haltbarkeitsgarantie").

Copying of this document and giving it to others and the use or communication of the contents thereof, are forbidden without express authority. Offenders are liable to the payment of damages. All rights are reserved in the event of the grant of a patent or the registration of the utility model or design.

Weitergabe sowie Vervielfältigung dieser Unterlage, Verwertung und Mitteilung ihres Inhalts nicht gestattet, soweit nicht ausdrücklich zugestanden. Zuwiderhandlungen verpflichten zu Schadenersatz. Alle Rechte für den Fall der Patenterteilung oder Gebrauchsmuster-Ertragung vorbehalten.

FAI2019-001469