

PRODUCT SPECIFICATION

Model No.: FYL-5014NURC1H-TL-S2

| Descriptions: |
|-------------------------------------|
| ■ Dice material: AlGaInP. |
| ■ Emitting Color: Super bright Red. |
| ■ Device Outline: Φ5mm round type. |
| ■ Lens Type: Water clear. |



| CUSTOMER APPROVED SIGNATURES | APPROVED BY | CHECKED BY | PREPARED BY |
|------------------------------|-------------|------------|-------------|
| | | | |

NINGBO FORYARD OPTOELECTRONICS CO.,LTD.

Add: NO.115 Qixin Road Ningbo Zhejiang China

Zip: 315051

Tel: 0086-574-87933652 87927870 87922206

Fax: 0086-574-87927917

E-mail: Sales@foryard.com (General)

[Http://www.foryard.com](http://www.foryard.com)

■ Absolute maximum ratings(Ta=25 ° c)

| Parameter | MAX. | Unit |
|---|---------------------|-------|
| Power Dissipation | 75 | mW |
| Peak Forward Current (1/10 Duty Cycle, 0.1ms Pulse Width) | 100 | mA |
| Continuous Forward Current | 30 | mA |
| Derating Linear From 50°C | 0.4 | mA/°C |
| Reverse Voltage | 5 | V |
| Operating Temperature Range | -40°C to +85°C | |
| Storage Temperature Range | -40°C to +100°C | |
| Lead Soldering Temperature[4mm(.157") From Body] | 260°C for 5 Seconds | |

■ Electrical and optical characteristics(Ta=25 ° c)

| Parameter | Symbol | Min. | Typ. | Max. | Unit | Test Condition |
|--------------------------|-----------------|------|------|------|---------|----------------|
| Luminous Intensity | I_v | - | 5500 | - | mcd | $I_F=20mA$ |
| Viewing Angle | $2\theta_{1/2}$ | 23 | 28 | 33 | Deg | |
| Peak Emission Wavelength | λ_p | - | 630 | - | nm | |
| Dominant Wavelength | λ_d | 620 | 625 | 630 | nm | |
| Spectral Line Half-Width | $\Delta\lambda$ | - | 15 | - | nm | |
| Forward Voltage | V_F | 1.7 | 2.0 | 2.5 | V | |
| Reverse Current | I_R | | | 10 | μA | $V_R=5V$ |

■ **Typical Electrical Characteristics Curves**
(25 °c Ambient Temperature Unless Otherwise Noted)

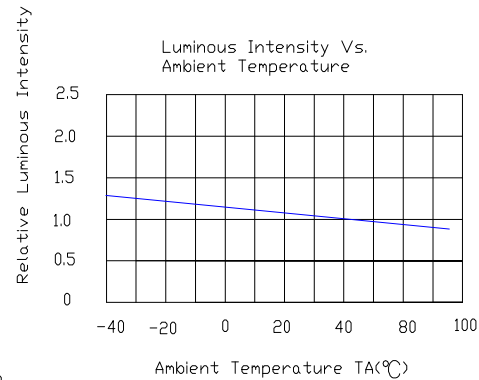
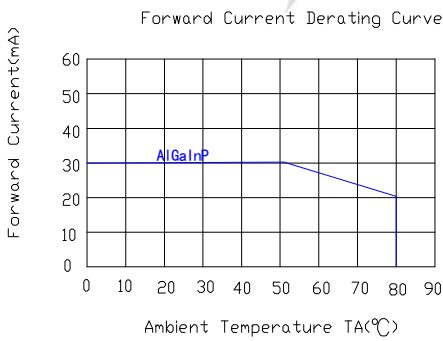
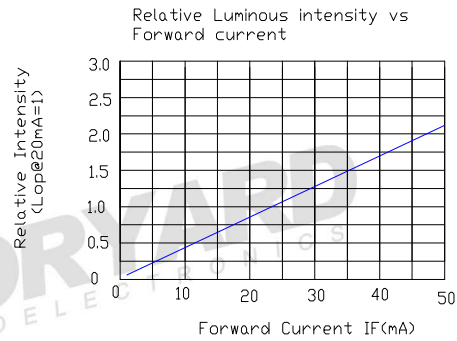
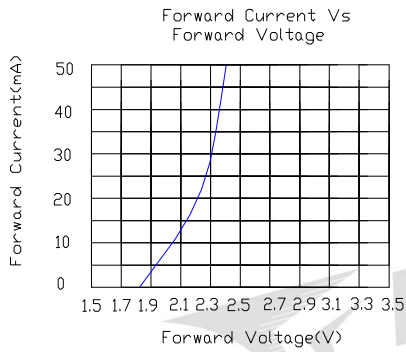
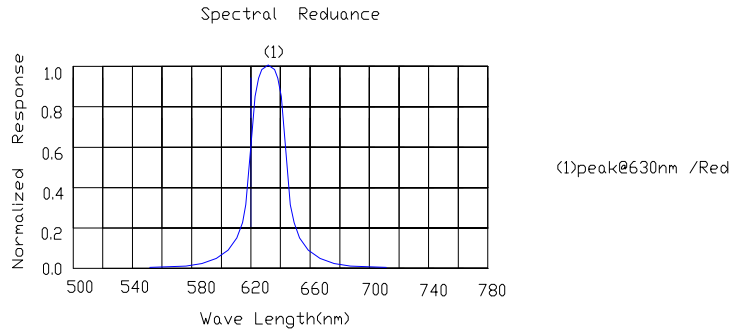

Radiation pattern.

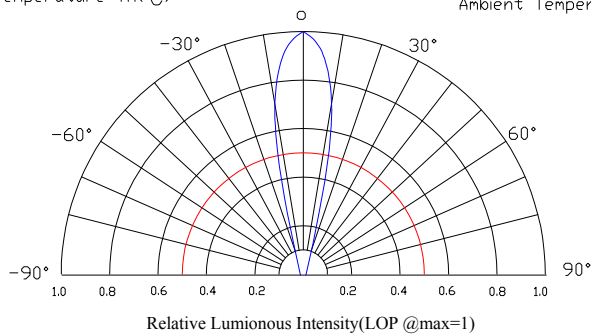

| | |
|------------|----------------------|
| Model. No. | FYL-5014NURC1H-TL-S2 |
| Rev. | A |

■ LAMP PACKING.

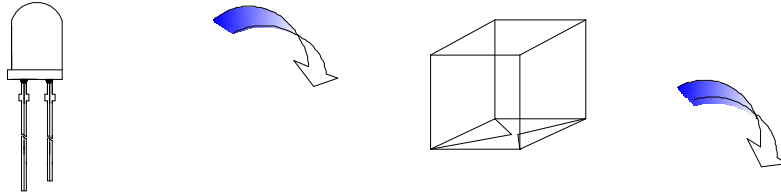

5mm 1000PCS/Polybag

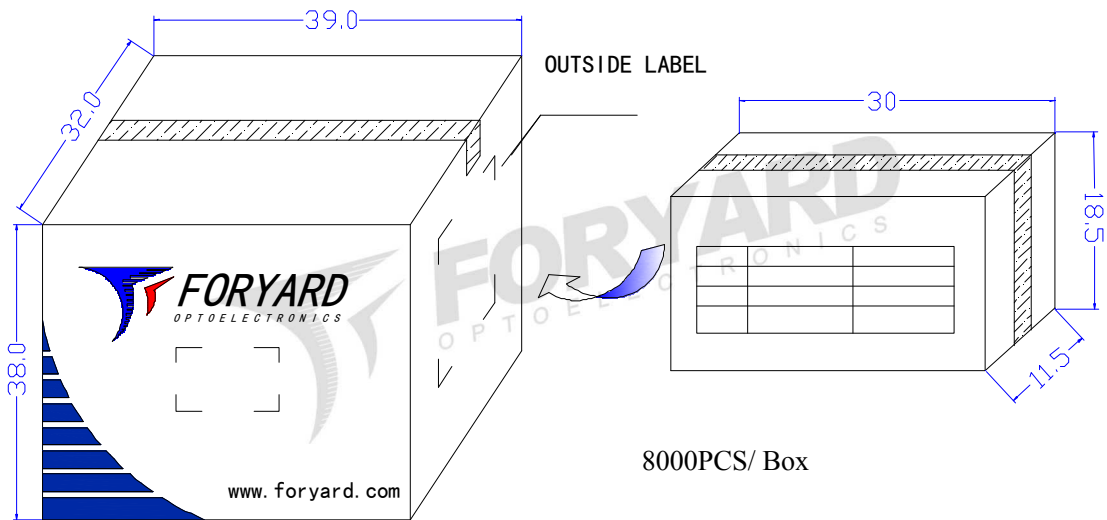
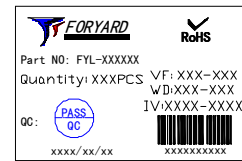

48000PCS/ Carton



OUTSIDE LABEL