

承 認 書

SPECIFICATION FOR APPROVAL

客 戶 :
CUSTOMER

LOMEX

承認圖號 :
APP. NO.

D130100819



系 列 :
SERIES

LU

使用溫度範圍 :
OPERATION TEMP.
RANGE

-40~+105°C

本公司料號 VENDOR'S PART NO.	貴公司料號 BUYER'S PART NO.
GLU***M*****0	

貴公司承認印 BUYER'S APPROVAL STAMP	智寶電子(東莞)有限公司 TEAPO ELECTRONICS(Dong Guan) CORPORATION	
		
	APPROVED BY:	TESTED BY:
		

智寶電子股份有限公司
台北縣新店市寶橋路 235 巷 1 弄 2 號

Teapo Electronics Corporation
3F,No.2,Alley 1.Lane 235,Baoqiao Rd., Xindian City, Taipei
County 231,Taiwan
Tel :+886-2-66298899 (Rep) Fax :+886-2-66296699

智寶電子(東莞)有限公司
廣東省東莞市塘廈鎮高麗工業區高麗一路
6A2、6A3 號

Teapo Electronic (Dongguan) Co.,Ltd.
Address: 6A3.6A2,Gaoli 1st Rd. Gaoli Ind. Zone, Tangxia Town,
Dongguan City, Guangdong 523726, China.
Tel : +86-769-8791-4676 Fax : +86-769-8791-4770

智寶電子(蘇州)有限公司
蘇州市高新區長江路 179 號 2 號門三樓

Teapo Electronic (Suzhou) Co., Ltd
3F,No.2,No.179,South Changjiang Rd.,High New District,Suzhou
City,Jiang Su,China.
Tel : +86-512-6636-6868 Fax :+86-512-6636-5556

I . Scope

This standard defines characteristics and dimensions for aluminum electrolytic capacitors named LU Series is low impedance and high ripple product.

II . Diagram of Dimensions

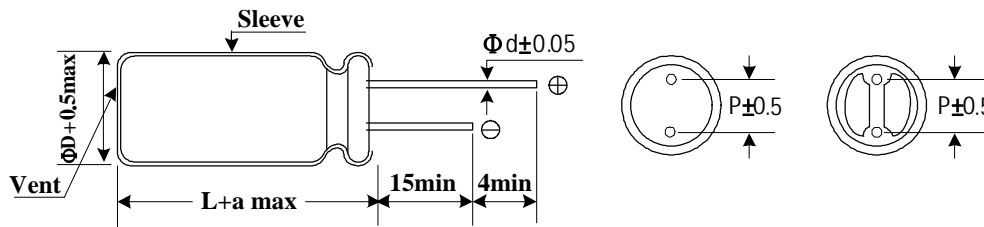

*Safety vent only for :Dimension $\geq 6.3 \times 11$

Case dimension(φD)	4	5	6.3	8	10	12	13	16	18
Lead space(P)	1.5	2.0	2.5	3.5	5.0			7.5	7.5
Lead diameter(φd)	0.45	0.5(0.45)	0.5(0.45)	0.6(0.5)	0.6			0.8	0.8
a	1.0	1.5(1.0)	1.5(1.0)	1.5(1.0)	1.5	2.0	2.0	2.0	2.0

() : L=7

III . Characteristics

Standard test condition

Unless otherwise specified all tests shall be performed at, or referred to, an ambient temperature of 20°C and a relative humidity not greater than 60%.

Operating Temperature Range

6.3~100VDC $-40 \sim +105^\circ\text{C}$

1. Electrical characteristics

(1). Rated Voltage and Surge Voltage

WV: Working Voltage (VDC)

SV: Surge Voltage (V)

WV	6.3	10	16	25	35	50	63	100
SV	8	13	20	32	44	63	79	125

(2). Leakage Current

The maximum leakage current is specified in the following formula after DC working voltage applied .

$$I=0.01CV \text{ or } 3 (\mu A) \text{ for 2 minutes whichever is greater}$$

where I: Leakage Current (μA)

C: Nominal Capacitance (μF)

V: Rated Voltage (V)

Measurement circuit

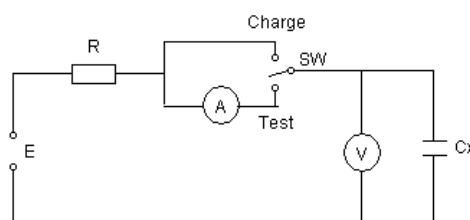

(3). Capacitance Tolerance

Capacitance tolerance should be within the range of -20%+20% which is measured at 120Hz/20°C

(4). Dissipation Factor

Dissipation Factor at 120Hz/ 20°C shall not exceed the values given in the table below.

WV	6.3	10	16	25	35	50	63	100
DF(%)	22	19	16	14	12	10	9	8

Note: Above DF specifications shall be 2% added for every 1000uF capacitor exceeding 1000uF.

(5). Low Temperature Characteristics

The ratio of impedance at -25°C/20°C and -40°C/+20°C of the capacitor shall be less than the following value at 120Hz.

WV	6.3	10	16	25	35	50	63	100
Z(120Hz)								
Z(-25°C)/Z(20°C)	2	2	2	2	2	2	2	2
Z(-40°C) /Z(20°C)	3	3	3	3	3	3	3	3

(6). Multiplier for Ripple Current

Frequency coefficient

Freq.(Hz)	50	120	1K	10K	100K
Cap(μF)					
5.6~390	0.60	0.70	0.85	0.95	1.00
470~1000	0.65	0.75	0.90	0.98	1.00
1200~6800	0.75	0.80	0.95	1.00	1.00

2. Mechanical Characteristics

Lead Pull Test

Capacitors shall be with stand the pull test shown in the following table.

Lead diameter (mm)	Load (Kg)	Test time (sec)
$d \leq 0.5$	0.5	30 $\begin{matrix} +5 \\ -0 \end{matrix}$
$0.5 < d \leq 0.8$	1.0	30 $\begin{matrix} +5 \\ -0 \end{matrix}$
$0.8 < d \leq 1.2$	2.5	30 $\begin{matrix} +5 \\ -0 \end{matrix}$

3. Endurance characteristics

(1). Ripple Life

After applying rated voltage with ripple current for specified time (refer to the below table for specified time) at 105 °C, the capacitors shall meet the following requirements.

Case Dia	L=7	$\varphi D \leq 6.3$	$\varphi D = 8$	$\varphi D = 10$	$\varphi D \geq 13$
Life	1000hrs	2000hrs	3000 hrs	4000 hrs	5000 hrs

*If dimension is down size, Endurance will be less 1000 hours than standard.

Capacitance Change	Within $\pm 25\%$ of the initial value
Dissipation Factor	Not more than 200% of the specified value
Leakage Current	Not more than the specified value

(2). Shelf Life

The following specifications shall be satisfied when the capacitors are restored to 20°C after exposing them at 105±2°C for 1000 hours (500+12 / -0 hours for L=7) without voltage applied.

*If dimension is down size, then Endurance is 1000 hours, the capacitors are restored to 20°C after exposing them at 105±2°C for 500+12/-0 hours without voltage applied.

Capacitance Change	Within $\pm 25\%$ of the initial value
Dissipation Factor	Not more than 200% of the specified value
Leakage Current	Not more than the specified value

(3). Solderability Test

The following specifications shall be satisfied when the lead wires are tested in solder bath at 245±5°C for 2.5±0.5 seconds, more than 95% of the terminal surface shall be covered with new solder.

(4). Solder Heat Resistance Test

The following specifications shall be satisfied when the lead wires are tested in solder bath at 275+2/-0°C for 20±0.5 seconds.

Capacitance Change	$\leq \pm 5\%$ of the initial value
Dissipation factor	\leq Initial specified value
Leakage Current	\leq Initial specified value

IV. Mounting

The paper separators and the electrolytic-conductive electrolytes in a non-solid aluminum electrolytic capacitor is flammable.

Leaking electrolyte on a PC board can gradually erode the copper traces, possibly causing smoke or burning by short-circuiting the copper traces.

Verify the following points when designing a PC board.

- (1) Provide the appropriate hole spacing on the PC board to match the terminal spacing of the capacitor.
- (2) Make the following open space over the vent so that the vent can operate correctly.

<u>Case diameter</u>	<u>Clearance</u>
ϕ 6.3 to ϕ 13 mm	2 mm minimum
ϕ 16 to ϕ 35 mm	3 mm minimum
ϕ 40 mm and up	5 mm minimum

- (3) Do not place any wires or copper traces over the vent of the capacitor.
- (4) Installing a capacitor with the vent facing the PC board needs an appropriate ventilation hole in PC board.
- (5) Do not pass any copper traces beneath the seal side of a capacitor.
The trace must pass 1 or 2 mm to the side of the capacitor.
- (6) Avoid placing any heat-generating objects adjacent to a capacitor or even on the reverse side of the PC board.
- (7) Do not pass any via holes or underneath a capacitor.
- (8) In designing double-sided PC boards, do not locate any copper trace under the seal side of a capacitor.

V. Storage Condition

- (1) Aluminum Electrolytic Capacitors should not be stored in high temperatures or where there is a high level of humidity. The suitable storage condition is 5~35°C and less than 75% in relative humidity.
- (2) Aluminum Electrolytic Capacitors should not be stored in damp conditions such as water, saltwater spray or oil spray.
- (3) Do not store Aluminum Electrolytic Capacitors in an environment full of hazardous gas (hydrogen sulfide, sulfurous acid gas, nitrous acid, chlorine gas, ammonium, etc...).
- (4) Aluminum Electrolytic Capacitors should not be stored under exposure to ozone, ultraviolet rays or radiation.
- (5) If a capacitor has been stored for more than one year under normal temperature (shorter if high temperature) and it shows increased leakage current, then a treatment by voltage application is recommended. The capacitor which hasn't been treated mustn't be used directly.

VI. Marking

Marking on capacitor include:

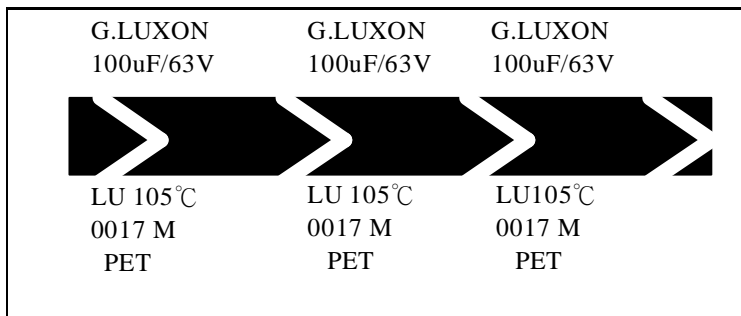

p G-LUXON trademark

p Series No.

p Nominal capacitance

p Max operating temperature

p Working voltage

p Date code

p Polarity

p Capacitance tolerance

Remark: Date code numbering system. Date code is indicated manufactured date

Manufactured year

Code	0	1	2	3	4	5	6	7	8	9
Year	2010	2011	2012	2013	2014	2015	2016	2017	2018	2019

Manufactured week

Week	1	2	3	4	5	6	7	8	9	10	11	12
Code	01	02	03	04	05	06	07	08	09	10	11	12

Sleeve Supplier(Made in Dongguan)

Supplier	SO LI	YNG SHINN	CHI YUAN	YUN LIN
Code	2	8	5	7
material	PET	PET	PET	PET

The above code descriptions are just examples, they haven't completely shown all sleeve suppliers.

VII. Catalog numbering

G-LUXON LU TYPE (Part Number)

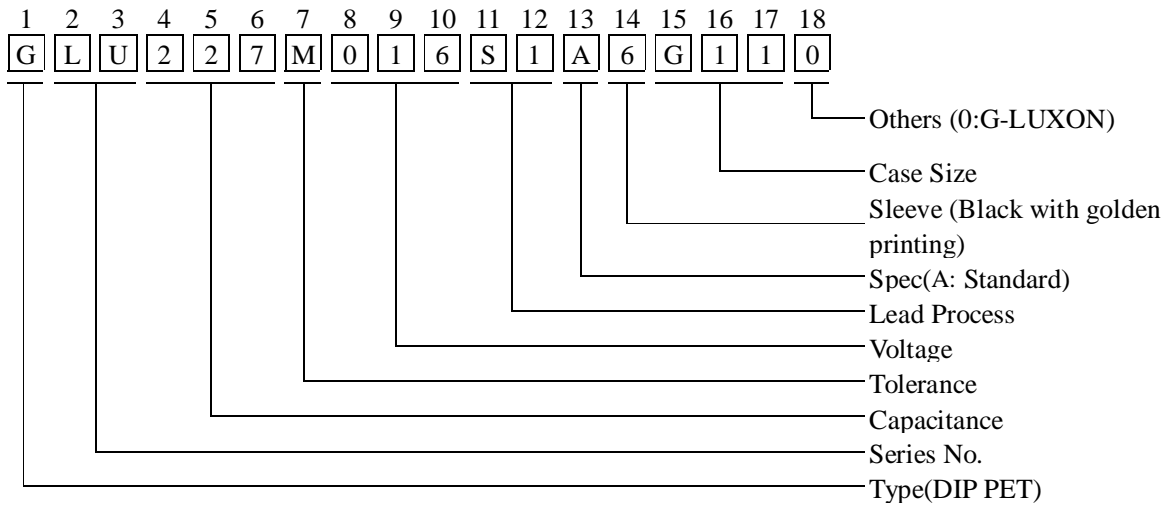

VIII. PACKAGING SPECIFICATION

Miniature Aluminum Electrolytic Capacitors

For Bulk: Standard Cutting & Forming

Classification	Standard Bulk				Cutting & Forming				Min. ordering amount
	Case size D*L(mm)	Vinyl bag	inner box 289*168*279 (mm)	outer carton 355*297*290 (mm)	gross weight (kg)	Vinyl bag	inner box 289*168*135 (mm)	outer carton 355*297*290 (mm)	
4×5	2,000	24,000	48,000	13	2,000	20,000	80,000	20	25
4×7	2,000	20,000	40,000	11	2,000	16,000	64,000	17	25
5×5	2,000	20,000	40,000	12	2,000	16,000	64,000	18	25
5×7	2,000	16,000	32,000	13	2,000	16,000	64,000	23	25
5×11	1,000	12,000	24,000	13	1,000	10,000	40,000	22	25
6.3×5	2,000	16,000	32,000	11	2,000	10,000	40,000	16	20
6.3×7	2,000	12,000	24,000	10	2,000	10,000	40,000	15	20
6.3×11	1,000	10,000	20,000	14	1,000	7,000	28,000	17	20
8×7	500	10,000	20,000	14	500	6,500	26,000	16	15
8×9,8×11	500	7,500	15,000	17	500	4,000	16,000	18	15
8×14	500	5,000	10,000	12	500	3,000	12,000	14	15
8×16	500	5,000	10,000	16	500	2,000	8,000	13	15
8×20	200	4,000	8,000	14	200	2,000	8,000	14	15
10×12.5	200	4,000	8,000	15	200	2,000	8,000	15	12
10×15	200	3,600	7,200	16	200	2,000	8,000	18	12
10×17	200	3,600	7,200	17	200	1,600	6,400	15	12
10×20	200	3,000	6,000	19	200	1,400	5,600	17	12
10×25	200	2,400	4,800	17	200	1,200	4,800	16	12
13×13,13×15	200	2,400	4,800	15	200	800	3,200	13	10
13×18,13×20	200	1,800	3,600	15	200	600	2,400	10	10
13×25	200	1,200	2,400	14	200	600	2,400	14	10
13×30	100	1,200	2,400	16	100	500	2,000	14	10
13×34,13×36	100	1,000	2,000	14	100	300	1,200	12	10
13×38,13×40	100	800	1,600	15	100	300	1,200	15	10

Classification	Standard Bulk				Cutting & Forming				Min. ordering amount
	Case size D*L(mm)	Vinyl bag	inner box (mm)	outer carton (mm)	gross weight (kg)	Vinyl bag	inner box (mm)	outer carton (mm)	
16X15、16X20	200	1000	2000	22	200	1000	2000	22	5
16X25	200	1000	2000	24	-	500	4000	44	5
16X30、16X32、	200	800	1600	20	-	500	3000	37	5
16X36、16X40	200	600	1200	22	-	500	3000	55	5
16X45	100	500	1000	22	-	-	-	-	5
18X15、18X20	200	800	1600	21	-	-	-	-	2.5
18X22、18X25	200	800	1600	23	-	500	2000	28	2.5
18X30	100	600	1200	25	-	-	-	-	2.5
18X32、18X36、18X40	100	500	1000	25	-	500	1000	25	2.5
18X45、18X50	100	300	600	21	-	600	1200	40	2.5
20X25	-	-	-	-	-	400	800	20	1.5
22X32	-	-	-	-	-	320	1920	55	1.5
22X30	-	-	-	-	-	400	800	25	1.5
22X35、22X40	100	300	600	21	-	400	800	27	1.5

For Taping Ammo & Reel

Classification Case size D φ (mm)	Ammo Tape					Reel Tape			Min. ordering amount kpcs
	inner box (mm)	quantity (pcs)	outer carton (mm)	quantity (pcs)	gross weight (kg)	inner carton 350*350*110 (mm)	outer carton 370*370*600 (mm)	gross weight (kg)	
4 φ	340×275×50	3,000	355×297×290	15,000	6	3,000	15,000	8	25
5 φ	340×230×50	2,000	355×252×290	10,000	6 ~ 7	2,400	12,000	8	25
6.3 φ	340×275×50	2,000	355×297×290	10,000	8	2,000	10,000	6	20
8 φ ×5-16L	340×230×50	1,000	355×252×290	5,000	7	1,600	8,000	12	15
8 φ ×20L	340×230×58	1,000	355×252×315	5,000	7	1,000	5,000	12	15
10 φ ×10~17L	340×230×50	600	355×252×290	3,000	7				12
10 φ ×20~25L	340×230×58	600	355×252×315	3,000	7	-	-	-	12
10 φ ×30L	340×230×65	600	355×252×290	2,400	7	-	-	-	12
13 φ ×32L below	315×275×65	400	355×297×290	1,600	5	-	-	-	10
13 φ ×36L above	315×275×74	400	355×297×337	1,600	5	-	-	-	10
16 φ ×32L below	315×275×65	300	355×297×290	1,200	5	-	-	-	5
16 φ ×36L above	315×275×74	300	355×297×337	1,200	5	-	-	-	5

Note : For 10 φ Reel Tape :

size	inner carton(pcs)	outer carton(pcs)
10 φ ×10~16L	1,200	6,000
10 φ ×17~20L	1,000	5,000

IX. Others

(1) All Teapo capacitors comply to RoHS(Restriction of Hazardous Substances) requirements where Chromium VI(Cr+6), Cadmium(Cd), Mercury(Hg), Lead(pb), Polybrominated biphenyls(PBBs) and Polybrominated biphenyl/diphenyl ethers (PBDEs/PBDEs) have not been detected [lower than MDL (Method Detection Limit)] per SGS certification test report..

(2) Satisfied characteristic JIS C 5101

(3) Aluminum Electrolytic Capacitors may be damaged by corrosion which is caused by any halogenated hydrocarbon solvents.

Please let us know in advance the solvent name and conditions for your PCB cleaning

X. Lead processing type and Taping

Code S1: Standard Type

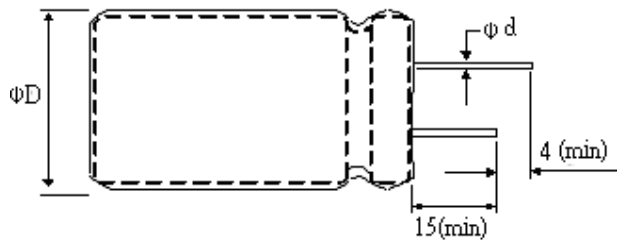

Code C5: Straight Cut

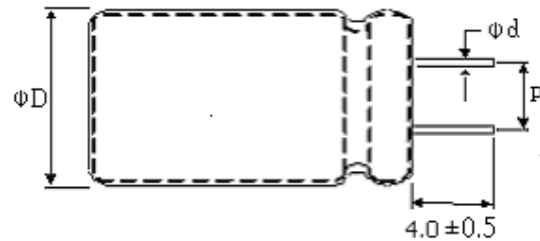

Code F6: Forming Cut($\phi 4 \sim \phi 8$)

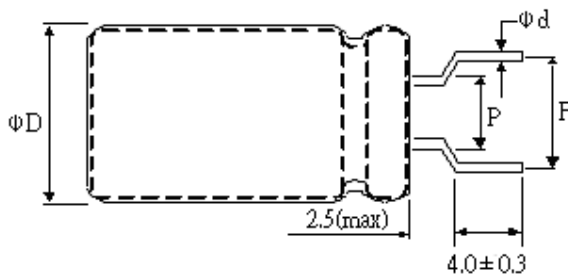

Code K2: Kink cut, & Crimping

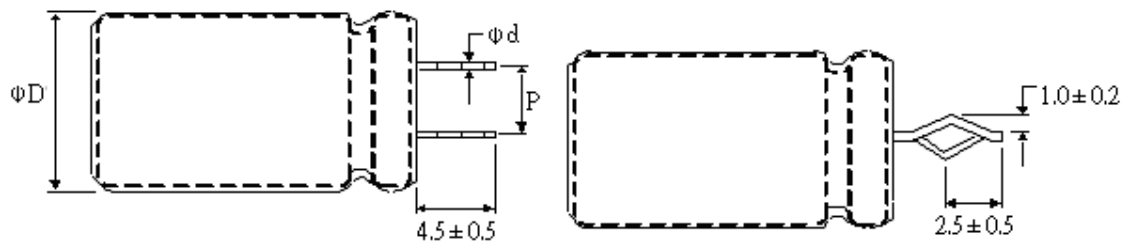

Code T1/R1: Ammo/Reel Tape(ϕ 4~ ϕ 6.3)

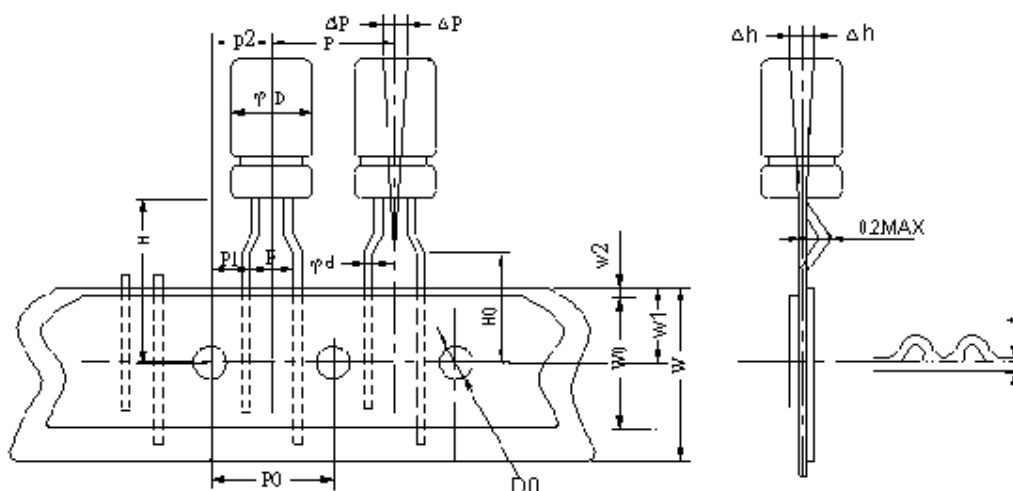

SYMBOL	CASE SIZE			TOLERANCE
	4x5	5x5~11	6.3x5~11	
ϕ d	0.45	0.45 or 0.5		± 0.05
P	12.7			± 1.0
P0	12.7			± 0.3
P1	3.85			± 0.5
P2	6.35			± 1.0
F	5.0			+0.6 / -0.2
W	18.0			± 0.5
W0	12.0 min			-
W1	9.0			± 0.5
W2	2.0 max			-
H	18.5			± 0.75
H0	16.0			± 0.5
D0	4.0			± 0.3
Δ P	0.2 max			-
Δ h	0.2 max			-
t	0.6			± 0.3

Code T1/R1 : Ammo / Reel Tape ($\phi 8$)

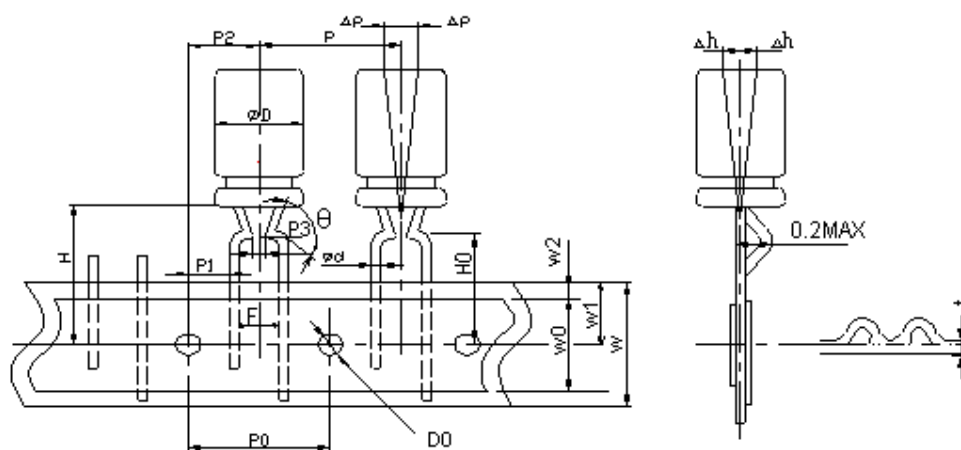

Unit: mm

SYMBOL	CASE SIZE	TOLERANCE
	8x5~20	
ϕd	0.45~0.6	± 0.05
P	12.7	± 1.0
P0	12.7	± 0.3
P1	3.85	± 0.7
P2	6.35	± 1.0
P3	2.5	+0.2 / -0.5
θ	110°	$\pm 15^\circ$
F	5.0	+0.6 / -0.2
W	18.0	± 0.5
W0	12.0 min	-
W1	9.0	± 0.5
W2	2.0 max	-
H	18.5	± 0.75
H0	16.0	± 0.5
D0	4.0	± 0.3
ΔP	0.2 max	-
Δh	0.2 max	-
t	0.6	± 0.3

Code T1/R1 : Ammo / Reel Tape ($\phi 10$)

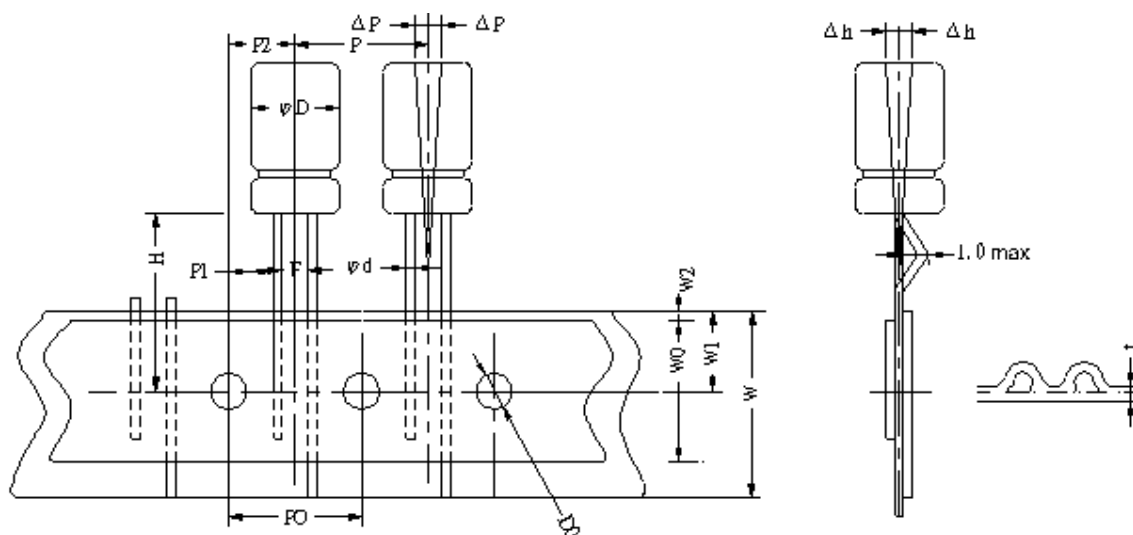

Unit: mm

SYMBOL	CASE SIZE	TOLERANCE
	10x10~30	
ϕd	0.6	± 0.05
P	12.7	± 1.0
P0	12.7	± 0.3
P1	3.85	± 0.5
P2	6.35	± 1.0
F	5.0	+0.6 / -0.2
W	18.0	± 0.5
W0	12.0 min	-
W1	9.0	± 0.5
W2	2.0 max	-
H	18.5	± 0.75
D0	4.0	± 0.3
ΔP	0.2 max	-
Δh	0.2 max	-
t	0.7	± 0.2

Code T1 : Ammo ($\phi 13 \sim \phi 18$)

13 ϕ

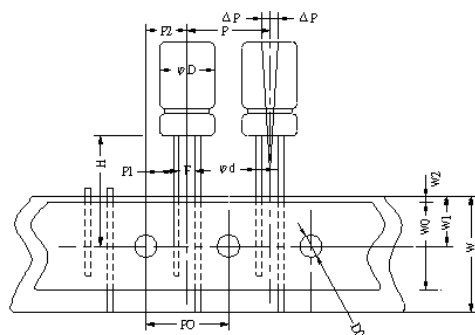

16-18 ϕ

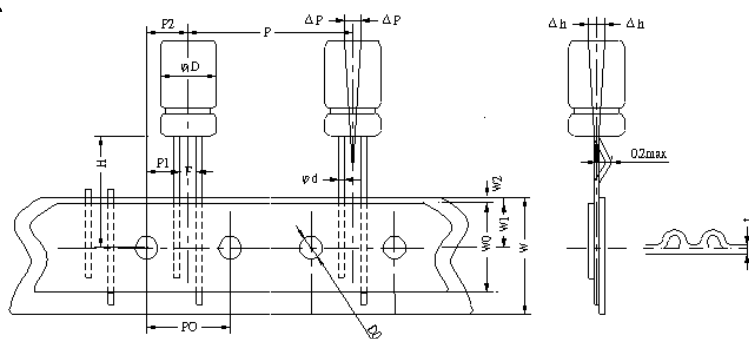

SYMBOL	CASE SIZE				TOLERANCE
	12.5x15~25	13x13~40	16x16~40	18x20~32	
ϕd	0.6	0.6~0.8	0.8		± 0.05
P	15.0		30.0		± 1.0
P0	15.0				± 0.3
P1	5.0		3.75		± 0.7
P2	7.5				± 1.3
F	5.0		7.5		+0.6 / -0.2
W	18				± 0.5
W0	12.0 min				-
W1	9.0				± 0.5
W2	2.0 max				-
H	18.5				± 0.75
D0	4.0				± 0.3
ΔP	0.2 max				-
Δh	0.2 max				-
t	0.7				± 0.3

Code T2/R2: Ammo/Reel Tape with straight lead

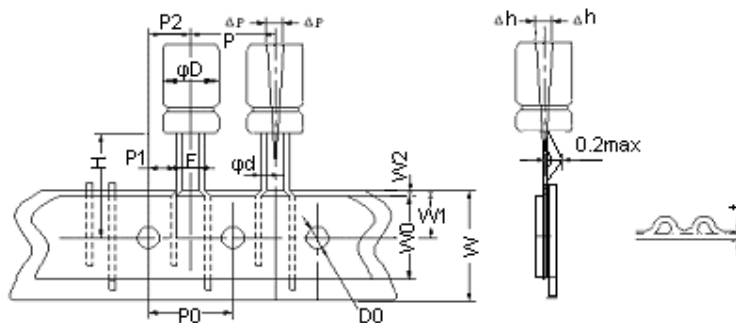

*F 表示成型后两导针中心之间的距离。

尺寸表(mm)

SYMBOL	CASE SIZE				TOLERANCE
	4×5~7	5×5~11	6.3×5~11	8×7~14	
φd	0.45	0.45 or 0.5		0.5 or 0.6	±0.05
F	1.5	2.0	2.5	3.5	+0.6/-0.2
P1	5.60	5.35	5.10	4.6	±0.5
P0	12.7				±0.3
P	12.7				±1.0
P2	6.35				±1.0
W	18.0				±0.5
W0	12.0min				-
W1	9.0				±0.5
W2	3.0max				-
H	18.5				±0.75
D0	4.0				±0.3
△p	0.2max				-
t	0.6				±0.2

■ Dimensions, Rated Ripple Current, Max Impedance

Capacitance (μF)	Rated (Surge) Voltage														
	6.3V (8)			10V (13)			16V (20)			25V (32)			35V (44)		
	SIZE	Ripple	Z	SIZE	Ripple	Z	SIZE	Ripple	Z	SIZE	Ripple	Z	SIZE	Ripple	Z
10													4x7	130	0.96
15										4x7	130	0.94	5x7	190	0.57
18							4x7	130	0.92	5x7	170	0.69	5x7	210	0.47
27				4x7	130	0.89	5x7	190	0.61	5x7	210	0.46	5x11	230	0.37
33				5x7	160	0.75	5x7	210	0.45	5x11	220	0.42	5x11	250	0.30
39	4x7	130	0.85	5x7	175	0.64	5x11	220	0.43	5x11	230	0.36	6.3x7	300	0.25
47	5x7	175	0.7	5x7	190	0.53	5x11	230	0.36	5x11	250	0.3	6.3x11	380	0.15
													8x7	350	0.19
56	5x7	190	0.56	5x7	210	0.44	5x11	250	0.3	6.3x7	300	0.24	6.3x11	410	0.13
													8x7	380	0.16
68	5x7	210	0.43	5x11	210	0.44	6.3x7	300	0.24	6.3x11	340	0.19	8x11	510	0.12
										8x7	310	0.22			
100	5x11	200	0.43	5x11	250	0.3	6.3x11	370	0.16	6.3x11	410	0.13	8x11	620	0.105
	6.3x7	240	0.35				8x7	350	0.18	8x7	380	0.15			
120	5x11	220	0.38	6.3x7	300	0.23	6.3x11	410	0.13	8x11	560	0.12	8x11	680	0.088
	6.3x7	270	0.29				8x7	380	0.15						
150	5x11	250	0.3	8x7	350	0.18	8x11	510	0.12	8x11	630	0.105	8x11	760	0.072
	6.3x7	300	0.23												
180	8x7	340	0.18	8x7	380	0.15	8x11	560	0.11	8x11	690	0.088	8x15	910	0.068
													10x12.5	930	0.065
220	8x7	380	0.15	6.3x11	410	0.13	8x11	620	0.1	8x11	760	0.072	10x12.5	1030	0.053
270	6.3x11	370	0.16	8x11	580	0.12	8x11	690	0.088	8x15	900	0.068	8x20	1250	0.041
										10x12.5	930	0.065			
330	6.3x11	410	0.13	8x11	640	0.1	8x11	760	0.072	10x12.5	1030	0.053	10x16	1430	0.038
470	8x11	680	0.086	8x11	760	0.072	8x15	1000	0.056	8x20	1250	0.041	10x20	1820	0.026
							10x12.5	1030	0.053	10x16	1430	0.038			
560	8x11	760	0.072	8x15	910	0.068	8x20	1140	0.049	10x20	1650	0.032	10x25	2150	0.023
				10x12.5	940	0.064	10x16	1300	0.046						
680	8x15	900	0.062	10x12.5	1030	0.053	8x20	1250	0.041	10x20	1820	0.026	13x20	2360	0.023
							10x16	1430	0.038						
820	8x15	1000	0.056	8x20	1130	0.05	10x20	1650	0.032	10x25	2150	0.023	13x25	2510	0.02
				10x16	1300	0.046									
1000	10x12.5	1030	0.053	8x20	1250	0.041	10x20	1820	0.026	13x20	2360	0.021	13x25	2770	0.018
				10x16	1430	0.038									
1200	8x20	1250	0.041	10x20	1820	0.026	10x25	2150	0.023	13x25	2510	0.02	13x30	3290	0.016
	10x16	1430	0.038										16x20	3140	0.018
1500	10x20	1820	0.026	10x25	2150	0.023	13x20	2360	0.021	13x25	2770	0.018	13x35	3400	0.015
1800	10x25	1940	0.025	13x20	2230	0.022	13x25	2510	0.02	13x30	3290	0.016	16x25	3460	0.016
										16x20	3140	0.018			
2200	10x25	2150	0.023	13x20	2360	0.021	13x25	2770	0.018	13x35	3400	0.015			
2700	13x20	2230	0.022	13x25	2510	0.02	13x30	3290	0.016	16x25	3460	0.016			
							16x20	3140	0.018						
3300	13x20	2360	0.021	13x25	2770	0.018	13x35	3400	0.015						
3900	13x25	2770	0.018	13x30	3290	0.016	16x25	3460	0.016						
				16x20	3140	0.018									
4700	13x30	3290	0.016	13x35	3400	0.015									
5600	13x35	3400	0.015	16x25	3460	0.016									
	16x20	3140	0.018												
6800	16x25	3460	0.016												

☆ Size: D φ x L (mm) ☆ Ripple Current : mA/rms, 105°C, 100KHz ☆ Impedance : Z(Ω), 20°C, 100KHz

■ Dimensions, Rated Ripple Current, Max Impedance

Capacitance (μ F)	Rated (Surge) Voltage								
	50V (63)			63V (79)			100V (125)		
	SIZE	Ripple	Z	SIZE	Ripple	Z	SIZE	Ripple	Z
5.6	4x7	130	1						
6.8	5x7	170	0.74				5x11	125	1.4
10	5x7	210	0.5				6.3x11	170	0.95
15	6.3x7	220	0.38	5x11	136	1.19	6.3x 11	210	0.57
	5x11	215	0.48						
22	6.3x7	300	0.26	6.3x11	176	0.88	8x11	330	0.44
	5x11	240	0.34						
27	8x7	340	0.21	6.3x11	192	0.58	8x11	360	0.36
33	8x7	380	0.17	6.3x11	216	0.47	8x15	375	0.3
39	6.3x11	330	0.16	8x11	308	0.42	8x15	450	0.25
47	6.3x11	360	0.15	8x11	336	0.35	10x12.5	450	0.24
56	6.3x11	390	0.14	8x11	400	0.35	8x20	570	0.19
68	8x11	600	0.11	8x15	488	0.26	10x16	580	0.18
				10x12.5	500	0.24			
82	8x11	660	0.09	8x15	536	0.22	10x20	750	0.13
				10x12.5	552	0.20	13x16	740	0.13
100	8x11	730	0.074	10x16	640	0.16	10x25	880	0.12
120	8x15	950	0.065	8x20	656	0.16	13x20	1050	0.094
				10x16	760	0.15			
150	10x12.5	980	0.061	10x20	808	0.13	13x25	1100	0.085
				13x16	832	0.13			
180	8x20	1190	0.046	10x20	880	0.11	13x25	1200	0.071
				13x16	912	0.11			
220	10x16	1370	0.042	10x25	1040	0.099	13x30	1410	0.063
							16x20	1300	0.071
270	10x20	1580	0.03	13x20	1200	0.081	13x35	1560	0.052
							16x25	1600	0.053
							18x20	1470	0.069
330	10x25	1870	0.028	13x25	1480	0.058	13x40	1700	0.046
390	13x20	1870	0.028	13x30	1640	0.063	16x32	1750	0.041
				16x20	1448	0.073	18x25	1620	0.049
470	13x20	2050	0.027	13x30	1800	0.061	16x36	1890	0.033
				16x20	1592	0.061	18x32	1780	0.039
560	13x25	2410	0.023	13x35	1960	0.047	16x40	2080	0.03
				16x25	2040	0.043	18x36	2060	0.031
680	13x30	2860	0.021	13x40	2224	0.039	18x40	2570	0.028
				18x20	1960	0.051			
820	13x35	2960	0.019	16x32	2248	0.035			
	16x20	2730	0.023	18x25	2224	0.042			
1000	16x32	3350	0.021	16x36	2272	0.028			
				18x32	2616	0.034			
1200				16x40	2672	0.026			
				18x36	2648	0.027			
1500				18x40	2736	0.024			

☆ Size: D ϕ x L (mm) ☆ Ripple Current : mA/rms, 105°C, 100KHz ☆ Impedance : Z(Ω), 20°C, 100KHz