

KTIR0221DS

Package Dimensions

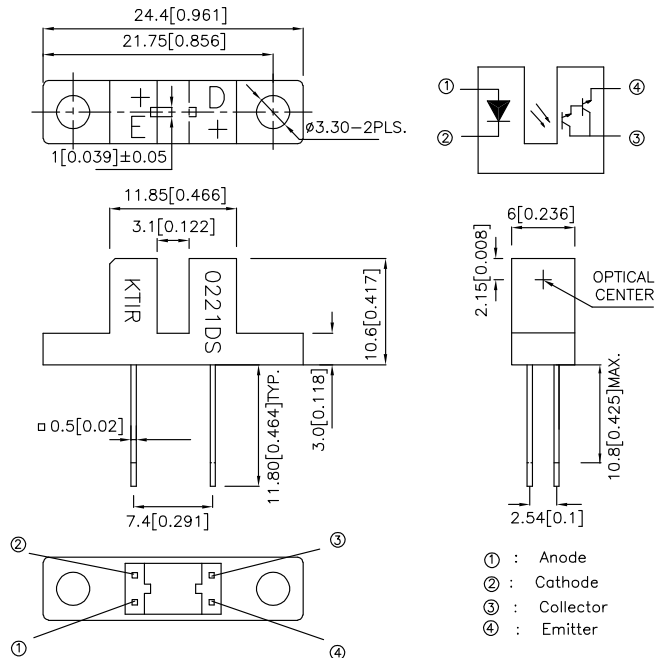

Features

- High sensing accuracy
- High current transfer ratio
- Both-sides mounting type
- RoHS compliant.

Applications

- OA equipment, such as floppy disk drives, printers, facsimiles, etc
- VCRs

Notes:

1. All dimensions are in millimeters (inches).
2. Tolerance is ± 0.25 (0.01") unless otherwise noted.
3. Lead spacing is measured where the leads emerge from the package.
4. Specifications are subject to change without notice.

Absolute Maximum Ratings ($T_A=25^\circ\text{C}$)

Parameter		Symbol	Rating	Unit
Input	Forward current	I_F	50	mA
	Reverse voltage	V_R	6	V
	Power dissipation	P_d	75	mW
	Peak Forward Current (Pulse Width $\leq 100\mu\text{S}$, Duty Ratio = 1%)	I_{FP}	1	A
Output	Collector-emitter voltage	V_{CEO}	35	V
	Emitter-collector voltage	V_{ECO}	6	V
	Collector current	I_C	40	mA
	Collector power dissipation	P_C	75	mW
Operating temperature		T_{opr}	-25~+85	$^\circ\text{C}$
Storage temperature		T_{stg}	-40~+100	$^\circ\text{C}$
Soldering temperature (1/16 inch from body for 5 seconds)		T_{sol}	260	$^\circ\text{C}$

Electro-optical Characteristics (Ta=25°C)

Parameter		Symbol	Conditions	Min.	Typ.	Max.	Unit	
Input	Forward voltage	V _F	I _F =20mA	—	1.2	1.5	V	
	Peak forward voltage	V _{FM}	I _{FM} =0.5A	—	2	4	V	
	Reverse current	I _R	V _R =5V	—	—	10	μA	
Output	Collector dark current	I _{CEO}	V _{CE} =10V, I _F =0mA	—	—	10 ⁻⁶	A	
Transfer Characteristics	Current transfer ratio	CTR	V _{CE} =2V, I _F =1mA	—	600	—	%	
	Collector-emitter saturation voltage	V _{CE(SAT)}	I _F =2mA, I _C =1mA	—	—	1.0	V	
	Response time	Rise time	t _r	V _{CE} =2V, I _C =10mA R _L =100Ω	—	90	400	μSec
		Fall time	t _f		—	80	300	μSec

Fig.1 Forward Current vs. Forward Voltage

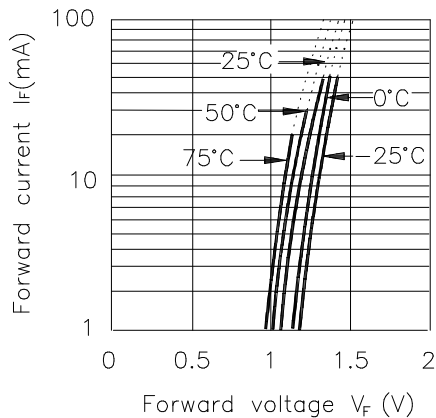

Fig.2 Collector Current vs. Forward Current

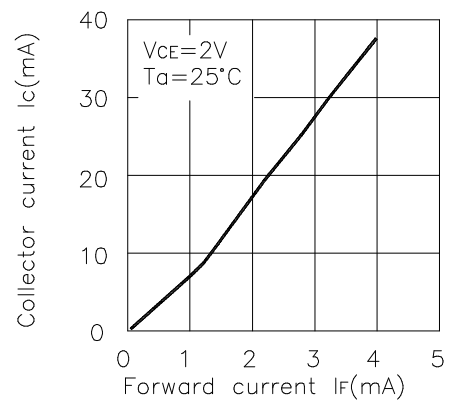

Fig.3 Collector Current vs. Collector-emitter Voltage

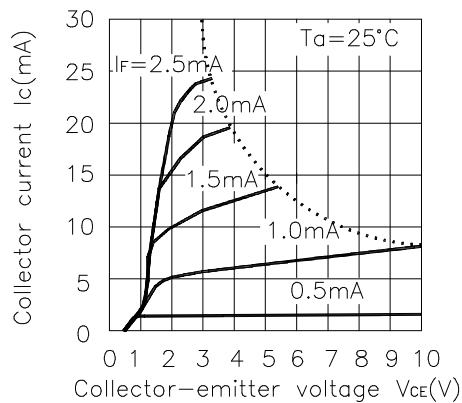

Fig.4 Collector Current vs. Ambient Temperature

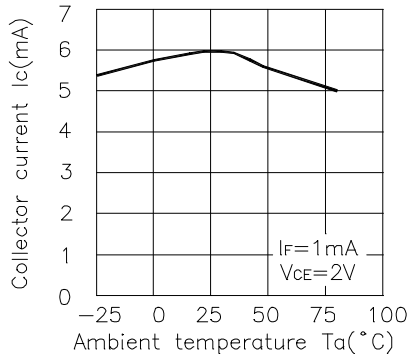

Fig.5 Collector-emitter Saturation Voltage vs. Ambient Temperature

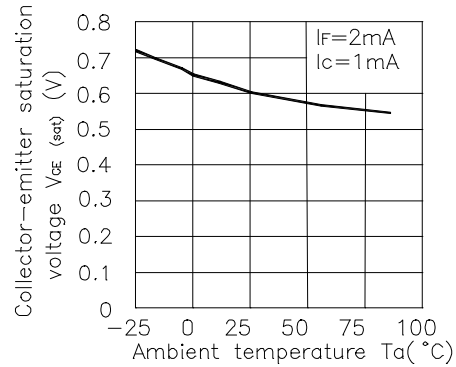

Fig.6 Relative Collector Current vs. Shield Distance(1)

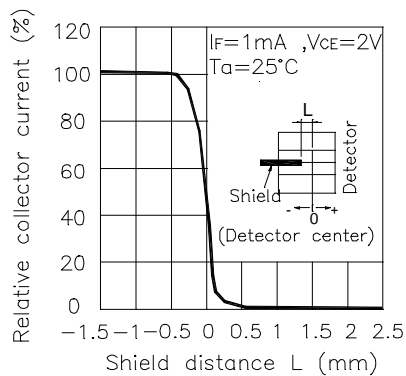

Fig.7 Relative Collector Current vs. Shield Distance(2)

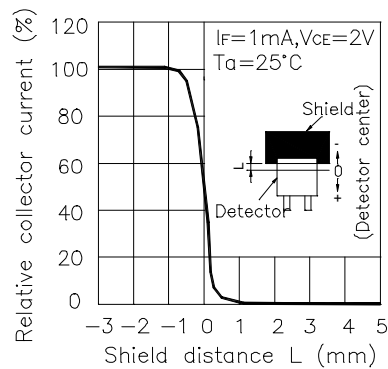
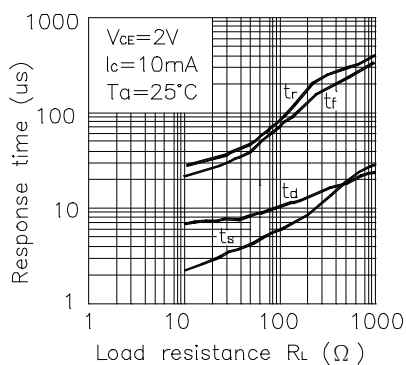

Fig.8 Response Time vs. Load Resistance



Test Circuit for Response Time

