

# OPA828 Low-Offset, Low-Drift, Low-Noise, 45-MHz, 36-V JFET-Input, RRO Operational Amplifier

## 1 Features

- Low Input Voltage Noise Density: 4 nV/ $\sqrt{\text{Hz}}$  at 1 kHz
- Input Voltage Noise: 0.1 Hz to 10 Hz: 60 nV<sub>RMS</sub>
- Low Input Bias Current: 1 pA
- Input Offset Voltage: 50  $\mu\text{V}$
- Input Offset Drift: 0.45  $\mu\text{V}/^\circ\text{C}$
- MUX-Friendly Inputs
- Gain Bandwidth: 45 MHz
- Slew Rate: 150 V/ $\mu\text{s}$
- 14-bit Settling Time: 120 ns
- Overload Power Limiter
- Wide Supply Voltage Range:  $\pm 4\text{ V}$  to  $\pm 18\text{ V}$
- Package: 8-pin SOIC

## 2 Applications

- Data Acquisition (DAQ)
- Optical Module
- Seismic Test Equipment
- Mixed Module
- Ultrasound Scanners

## 3 Description

The OPA828 JFET is the next generation OPA627 and OPA827 operational amplifier (op amp), combining high speed with high DC precision and AC performance. This op amp supplies low-offset voltage (50  $\mu\text{V}$ ), low-drift over temperature (0.45  $\mu\text{V}/^\circ\text{C}$  typical), low bias current (1 pA typical), and low noise (4 nV/ $\sqrt{\text{Hz}}$  typical) with only 60-nV<sub>RMS</sub> 0.1- to 10-Hz noise. The OPA828 operates over a wide supply-voltage range,  $\pm 4\text{ V}$  to  $\pm 18\text{ V}$  on a supply current (5.5 mA/channel typical).

AC characteristics, including a 45-MHz gain bandwidth product (GBW), a slew rate of 150 V/ $\mu\text{s}$ , and precision dc characteristics, make the OPA828 an excellent choice for a variety of systems. These include high-speed and high-resolution data-acquisition systems, such as 16-bit to 18-bit mixed signal systems, transimpedance (I/V-conversion) amplifiers, filters, precision  $\pm 10\text{-V}$  front ends, and high-impedance sensor-interface applications.

The OPA828 is available in the industry-standard 8-pin SOIC surface-mount package and is specified from  $-40^\circ\text{C}$  to  $+125^\circ\text{C}$ .

### Device Information<sup>(1)</sup>

PART NUMBER	PACKAGE	BODY SIZE (NOM)
OPA828	SOIC (8)	4.90 mm x 3.91 mm

(1) For all available packages, see the orderable addendum at the end of the data sheet.

### Open-Loop Gain and Phase vs Frequency

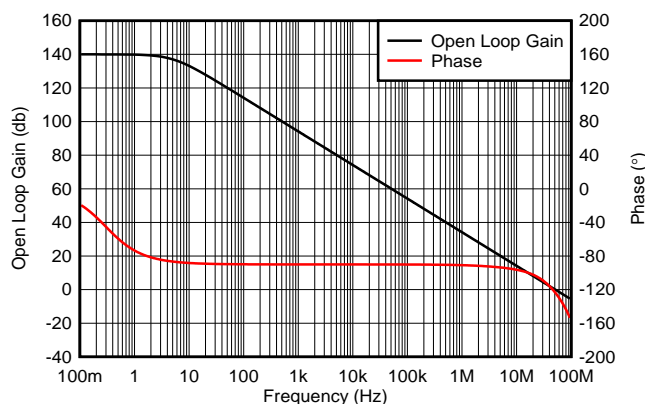

### Offset Voltage Drift

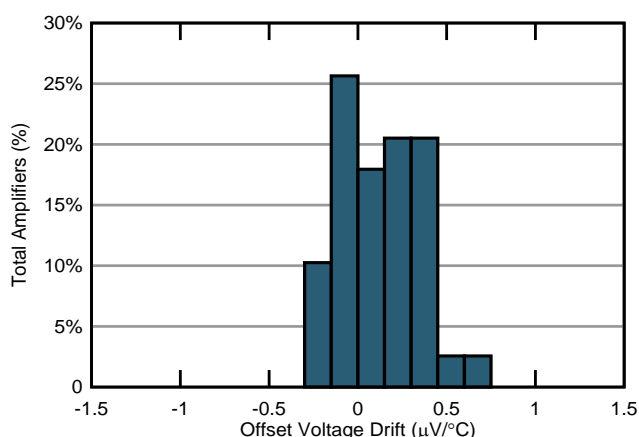

## Table of Contents

<b>1 Features</b> .....	<b>1</b>	<b>8 Application and Implementation</b> .....	<b>27</b>
<b>2 Applications</b> .....	<b>1</b>	8.1 Application Information.....	27
<b>3 Description</b> .....	<b>1</b>	8.2 Typical Applications .....	27
<b>4 Revision History</b> .....	<b>2</b>	<b>9 Power Supply Recommendations</b> .....	<b>31</b>
<b>5 Pin Configuration and Functions</b> .....	<b>3</b>	<b>10 Layout</b> .....	<b>32</b>
<b>6 Specifications</b> .....	<b>4</b>	10.1 Layout Guidelines .....	32
6.1 Absolute Maximum Ratings .....	4	10.2 Layout Example .....	33
6.2 ESD Ratings.....	4	<b>11 Device and Documentation Support</b> .....	<b>34</b>
6.3 Recommended Operating Conditions.....	4	11.1 Device Support.....	34
6.4 Thermal Information .....	4	11.2 Documentation Support .....	34
6.5 Electrical Characteristics.....	5	11.3 Receiving Notification of Documentation Updates	34
6.6 Typical Characteristics.....	8	11.4 Community Resource.....	34
<b>7 Detailed Description</b> .....	<b>16</b>	11.5 Trademarks .....	34
7.1 Overview .....	16	11.6 Electrostatic Discharge Caution.....	34
7.2 Functional Block Diagram .....	16	11.7 Glossary .....	34
7.3 Feature Description.....	17	<b>12 Mechanical, Packaging, and Orderable</b>	
7.4 Device Functional Modes.....	26	<b>Information</b> .....	<b>34</b>

## 4 Revision History

NOTE: Page numbers for previous revisions may differ from page numbers in the current version.

Changes from Revision A (November 2018) to Revision B	Page
• First release of production-data data sheet.....	1

## 5 Pin Configuration and Functions

**D Package  
8-Pin SOIC  
Top View**

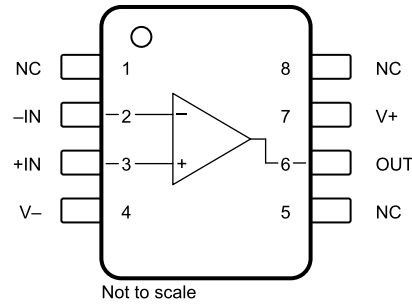

NC: no internal connection

### Pin Functions

NAME	NO.	I/O	DESCRIPTION
-IN	2	I	Negative (inverting) input
+IN	3	I	Positive (non-inverting) input
NC	1, 5, 8	—	No internal connection (can be left floating or grounded)
OUT	6	O	Output
V+	7	—	Positive (highest) power supply
V-	4	—	Negative (lowest) power supply

## 6 Specifications

### 6.1 Absolute Maximum Ratings

over operating free-air temperature range (unless otherwise noted)<sup>(1)</sup>

		MIN	MAX	UNIT	
Supply voltage, $V_S = (V+) - (V-)$	Single-supply		40	V	
	Dual-supply		±20		
Signal input pins	Voltage	Common-mode <sup>(2)</sup>	(V-) – 0.5		(V+) + 0.5
		Differential <sup>(3)</sup>			(V+) – (V-)
	Current <sup>(2)</sup>			±10	mA
Output short current <sup>(4)</sup>			Continuous		
Temperature	Junction, $T_J$	-55	150	°C	
	Storage, $T_{stg}$	-65	150		

- (1) Stresses beyond those listed under *Absolute Maximum Ratings* may cause permanent damage to the device. These are stress ratings only, which do not imply functional operation of the device at these or any other conditions beyond those indicated under *Recommended Operating Ratings*. Exposure to absolute-maximum-rated conditions for extended periods may affect device reliability.
- (2) Input terminals are diode-clamped to the power-supply rails. Current-limit input signals that can swing more than 0.5 V beyond the supply rails to 10 mA or less.
- (3) Input terminals are not clamped to each other with anti-parallel diodes. The JFET input stage allows large differential voltage values up to the supply voltage of the device.
- (4) Short circuit to ground, one amplifier per package.

### 6.2 ESD Ratings

		VALUE	UNIT	
$V_{(ESD)}$	Electrostatic discharge	Human body model (HBM), per ANSI/ESDA/JEDEC JS-001, all pins <sup>(1)</sup>	±2000	V
		Charged device model (CDM), per JEDEC specification JESD22-C101, all pins <sup>(2)</sup>	±500	

- (1) JEDEC document JEP155 states that 500-V HBM allows safe manufacturing with a standard ESD control process.
- (2) JEDEC document JEP157 states that 250-V CDM allows safe manufacturing with a standard ESD control process.

### 6.3 Recommended Operating Conditions

over operating free-air temperature range (unless otherwise noted)

		MIN	NOM	MAX	UNIT
$V_S$	Supply voltage, (V+) – (V-)	Single supply		36	V
		Dual supply	±4	±18	
	Ambient temperature	-40		125	°C

### 6.4 Thermal Information

THERMAL METRIC <sup>(1)</sup>		OPA828	UNIT
		D (SOIC)	
		8 PINS	
$R_{\theta JA}$	Junction-to-ambient thermal resistance	121.5	°C/W
$R_{\theta JC(top)}$	Junction-to-case (top) thermal resistance	64.3	°C/W
$R_{\theta JB}$	Junction-to-board thermal resistance	65	°C/W
$\Psi_{JT}$	Junction-to-top characterization parameter	18	°C/W
$\Psi_{JB}$	Junction-to-board characterization parameter	64.3	°C/W

- (1) For more information about traditional and new thermal metrics, see the [Semiconductor and IC Package Thermal Metrics](#) application report.

## 6.5 Electrical Characteristics

At  $T_A = 25^\circ\text{C}$ ,  $(V+) = 15\text{ V}$ ,  $(V-) = -15\text{ V}$ ,  $V_{CM} = V_O = \text{midsupply}$ ,  $C_L = 20\text{ pF}$ ,  $R_L = 2\text{ k}\Omega$  connected to midsupply, unless otherwise noted.

PARAMETER		TEST CONDITIONS		MIN	TYP	MAX	UNIT	
<b>OFFSET VOLTAGE</b>								
$V_{OS}$	Input offset voltage				$\pm 50$	$\pm 300$	$\mu\text{V}$	
		$T_A = 0^\circ\text{C to } 85^\circ\text{C}$				$\pm 350$		
		$T_A = -40^\circ\text{C to } 125^\circ\text{C}$				$\pm 400$		
$dV_{OS}/dT$	Input offset voltage drift	$T_A = 0^\circ\text{C to } 85^\circ\text{C}$			$\pm 0.3$	$\pm 1.3$	$\mu\text{V}/^\circ\text{C}$	
		$T_A = -40^\circ\text{C to } 125^\circ\text{C}$			$\pm 0.45$	$\pm 1.5$		
PSRR	Power-supply rejection ratio	$8\text{ V} \leq V_S \leq 36\text{ V}$				1.4	$\pm 5.6$	$\mu\text{V}/\text{V}$
			$T_A = -0^\circ\text{C to } 85^\circ\text{C}$				$\pm 7$	
			$T_A = -40^\circ\text{C to } 125^\circ\text{C}$				$\pm 10$	
<b>INPUT BIAS CURRENT</b>								
$I_B$	Input bias current				$\pm 1$	$\pm 8$	$\mu\text{A}$	
		$T_A = 0^\circ\text{C to } 85^\circ\text{C}$				$\pm 400$		
		$T_A = -40^\circ\text{C to } 125^\circ\text{C}$				$\pm 3$		
$I_{OS}$	Input offset current				$\pm 1$	$\pm 8$	$\mu\text{A}$	
		$T_A = 0^\circ\text{C to } 85^\circ\text{C}$				$\pm 500$		
		$T_A = -40^\circ\text{C to } 125^\circ\text{C}$				$\pm 1.5$		
<b>NOISE</b>								
$E_N$	Input voltage noise	$f = 0.1\text{ Hz to } 10\text{ Hz, peak-to-peak}$			0.34		$\mu\text{V}_{PP}$	
		$f = 0.1\text{ Hz to } 10\text{ Hz, RMS}$			0.06		$\mu\text{V}_{RMS}$	
$e_N$	Input voltage noise density	$f = 10\text{ Hz}$			7.5		$\text{nV}/\sqrt{\text{Hz}}$	
		$f = 100\text{ Hz}$			4.8			
		$f = 1\text{ kHz}$			4			
$i_N$	Input current noise density	$f = 1\text{ kHz}$			1.2		$\text{fA}/\sqrt{\text{Hz}}$	
<b>INPUT VOLTAGE</b>								
$V_{CM}$	Common-mode voltage range			$(V-) + 2.5$		$(V+) - 3.5$	V	
CMRR	Common-mode rejection ratio	$(V-) + 2.5\text{ V} < V_{CM} < (V+) - 3.5\text{ V}$			108	115	dB	
				$T_A = 0^\circ\text{C to } 85^\circ\text{C}$	105			
				$T_A = -40^\circ\text{C to } 125^\circ\text{C}$	103			
<b>INPUT IMPEDANCE</b>								
$Z_{ID}$	Differential				$10^{12} \parallel 6$		$\Omega \parallel \text{pF}$	
$Z_{ICM}$	Common-mode				$10^{12} \parallel 9$		$\Omega \parallel \text{pF}$	

## Electrical Characteristics (continued)

At  $T_A = 25^\circ\text{C}$ ,  $(V_+) = 15\text{ V}$ ,  $(V_-) = -15\text{ V}$ ,  $V_{\text{CM}} = V_O = \text{midsupply}$ ,  $C_L = 20\text{ pF}$ ,  $R_L = 2\text{ k}\Omega$  connected to midsupply, unless otherwise noted.

PARAMETER		TEST CONDITIONS		MIN	TYP	MAX	UNIT
<b>OPEN-LOOP GAIN</b>							
$A_{\text{OL}}$	Open-loop voltage gain	$(V_-) + 1.6\text{ V} < V_O < (V_+) - 1.6\text{ V}$ , $R_L = 600\ \Omega$		120	130		dB
		$(V_-) + 1.5\text{ V} < V_O < (V_+) - 1.5\text{ V}$ , $R_L = 10\text{ k}\Omega$		120	130		
		$T_A = -0^\circ\text{C}$ to $85^\circ\text{C}$	$(V_-) + 1.6\text{ V} < V_O < (V_+) - 1.6\text{ V}$ , $R_L = 600\ \Omega$	117			
			$(V_-) + 1.5\text{ V} < V_O < (V_+) - 1.5\text{ V}$ , $R_L = 10\text{ k}\Omega$	118			
		$T_A = -40^\circ\text{C}$ to $125^\circ\text{C}$	$(V_-) + 1.6\text{ V} < V_O < (V_+) - 1.6\text{ V}$ , $R_L = 600\ \Omega$	114			
			$(V_-) + 1.5\text{ V} < V_O < (V_+) - 1.5\text{ V}$ , $R_L = 10\text{ k}\Omega$	114			
<b>FREQUENCY RESPONSE</b>							
	Unity gain frequency	$V_O = 10\text{ mV}_{\text{PP}}$ , $C_L = 30\text{ pF}$			45		MHz
	Phase margin	$V_O = 10\text{ mV}_{\text{PP}}$ , $C_L = 30\text{ pF}$			57		Degrees
GBW	Gain-bandwidth product	$V_O = 10\text{ mV}_{\text{PP}}$ , $C_L = 30\text{ pF}$			45		MHz
SR	Slew rate	$V_O = 10\text{-V}$ step	$G = +1$		150		V/ $\mu\text{s}$
			$G = -1$		150		
$t_s$	Settling time (input to output)	$V_O = 10\text{-V}$ step, $C_L = 30\text{ pF}$ , $G = -1$	$T_o \pm 0.0244\%$ (12-bit accuracy)		110		ns
			$T_o \pm 0.0061\%$ (14-bit accuracy)		120		
	Overshoot	$V_O = 100\text{-mV}$ step, $G = +1$ , $C_L = 30\text{ pF}$	$V_O = 100\text{-mV}$ step, $G = +1$ , $C_L = 30\text{ pF}$		8%		
	Overload recovery time	$G = -10$			55		ns
	Total harmonic distortion + noise (THD+N)	$V_O = 3.5\text{ V}_{\text{RMS}}$ , $G = +1$ , $f = 1\text{ kHz}$	$R_L = 10\text{ k}\Omega$		0.000028%		dB
					-130		
			$R_L = 600\ \Omega$		0.000028%		dB
					-130		
HD2	Second-order harmonic distortion	$V_O = 5\text{ V}_{\text{PP}}$ , $G = +1$	$f = 100\text{ kHz}$		119		dBc
			$f = 500\text{ kHz}$		90		
HD3	Third-order harmonic distortion	$V_O = 5\text{ V}_{\text{PP}}$ , $G = +1$	$f = 100\text{ kHz}$		125		dBc
			$f = 500\text{ kHz}$		105		
IMD	Second-order intermodulation distortion	SMPTE/DIN two-tone, 4:1 (60 Hz and 7 kHz), $G = 1$ , $V_O = 3\text{ V}_{\text{RMS}}$ , $R_L = 2\text{ k}\Omega$ , 90-kHz measurement bandwidth			132		dB
	Third-order intermodulation distortion	CCIF twin-tone (19 kHz and 20 kHz), $G = 1$ , $V_O = 3\text{ V}_{\text{RMS}}$ , $R_L = 2\text{ k}\Omega$ , 90-kHz measurement bandwidth			137		dB

## Electrical Characteristics (continued)

At  $T_A = 25^\circ\text{C}$ ,  $(V+) = 15\text{ V}$ ,  $(V-) = -15\text{ V}$ ,  $V_{CM} = V_O = \text{midsupply}$ ,  $C_L = 20\text{ pF}$ ,  $R_L = 2\text{ k}\Omega$  connected to midsupply, unless otherwise noted.

PARAMETER		TEST CONDITIONS		MIN	TYP	MAX	UNIT	
<b>OUTPUT</b>								
	Output voltage swing	$R_L = 10\text{ k}\Omega$			0.9	1.2	V	
		$R_L = 600\ \Omega$			1.2			
$I_O$	Output current	For linear operation, $A_{OL} \geq 120\text{ dB}$			$\pm 30$		mA	
$I_{SC}$	Short-circuit current				$\pm 50$		mA	
$C_L$	Capactive load drive				<a href="#">See Typical Curves</a>		pF	
$Z_O$	Open-loop output impedance	$f = 1\text{ MHz}$ , $I_O = 0\text{ mA}$			13.5		$\Omega$	
<b>POWER SUPPLY</b>								
$V_S$	Specified voltage			$\pm 4$		$\pm 18$	V	
$I_Q$	Quiescent current (per amplifier)	$I_O = 0\text{ A}$			5.5	6.2	mA	
		$I_O = 0\text{ A}$	$T_A = 0^\circ\text{C to } 85^\circ\text{C}$				7.1	mA
			$T_A = -40^\circ\text{C to } 125^\circ\text{C}$				7.9	mA
<b>TEMPERATURE RANGE</b>								
$T_A$	Operating ambient temperature			-40		125	$^\circ\text{C}$	

## 6.6 Typical Characteristics

**Table 1. Table of Graphs**

DESCRIPTION	FIGURE
Input Voltage Noise Density vs Frequency	<a href="#">Figure 1</a>
. Integrated Input Voltage Noise vs Bandwidth	<a href="#">Figure 2</a>
Total Harmonic Distortion + Noise Ratio vs Frequency	<a href="#">Figure 3</a>
Total Harmonic Distortion + Noise Ratio vs Output Amplitude	<a href="#">Figure 4</a>
. 0.1-Hz To 10-Hz Noise	<a href="#">Figure 5</a>
Offset Voltage Production Distribution	<a href="#">Figure 6</a>
Offset Voltage Drift Production Distribution	<a href="#">Figure 7</a>
Offset Voltage vs Common-Mode Voltage	<a href="#">Figure 8</a>
Offset Voltage vs Power Supply Voltage	<a href="#">Figure 9</a>
Offset Voltage vs Output Voltage	<a href="#">Figure 10</a>
. Offset Voltage vs Temperature	<a href="#">Figure 11</a>
Input Bias and Input Offset Current vs Common-Mode Voltage	<a href="#">Figure 12</a>
Input Bias and Input Offset Current vs Temperature	<a href="#">Figure 13</a>
Quiescent Current vs Output Voltage	<a href="#">Figure 14</a>
Quiescent Current vs Temperature	<a href="#">Figure 15</a>
Output Voltage Swing vs Output Sourcing Current	<a href="#">Figure 16</a>
Output Voltage Swing vs Output Sinking Current	<a href="#">Figure 17</a>
Power-Supply Rejection Ratio vs Frequency	<a href="#">Figure 18</a>
Common-Mode Rejection Ratio vs Frequency	<a href="#">Figure 19</a>
Power-Supply Rejection Ratio vs Temperature	<a href="#">Figure 20</a>
Common-Mode Rejection Ratio vs Temperature	<a href="#">Figure 21</a>
Open-Loop Gain and Phase vs Frequency	<a href="#">Figure 22</a>
Closed-Loop Gain vs Frequency	<a href="#">Figure 23</a>
Open-Loop Gain vs Temperature	<a href="#">Figure 24</a>
Open-Loop Output Impedance vs Frequency	<a href="#">Figure 25</a>
Small-Signal Overshoot vs Capacitive Load, Gain = +1	<a href="#">Figure 26</a>
Small-Signal Overshoot vs Capacitive Load, Gain = -1	<a href="#">Figure 27</a>
No Phase Reversal	<a href="#">Figure 28</a>
Positive Overload Recovery	<a href="#">Figure 29</a>
Negative Overload Recovery	<a href="#">Figure 30</a>
. Small-Signal Step Response	<a href="#">Figure 31</a>
Large-Signal Step Response	<a href="#">Figure 32</a>
12-bit, 14-bit Settling Time	<a href="#">Figure 33</a>
Short-Circuit Current vs Temperature	<a href="#">Figure 35</a>
Slew Rate vs Temperature	<a href="#">Figure 36</a>
Slew Rate vs Output Step Size	<a href="#">Figure 37</a>
Maximum Output Voltage vs Frequency	<a href="#">Figure 38</a>
Intermodulation Distortion	<a href="#">Figure 39</a>
Electromagnetic Interference Rejection	<a href="#">Figure 40</a>
Harmonic Distortion vs Frequency	<a href="#">Figure 41</a>



At  $T_A = 25^\circ\text{C}$ ,  $R_L = 2\text{ k}\Omega$  connected to midsupply, and  $V_{CM} = V_{OUT} = \text{midsupply}$ ,  $V_S = \pm 18\text{V}$ , unless otherwise noted.

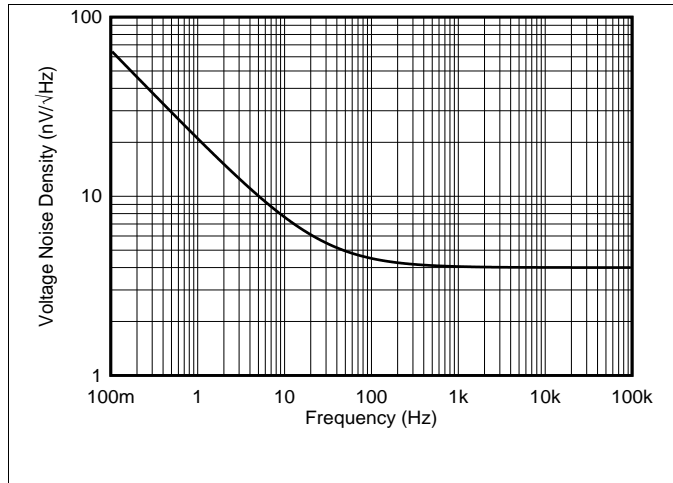

Figure 1. Input Voltage Noise Density vs Frequency

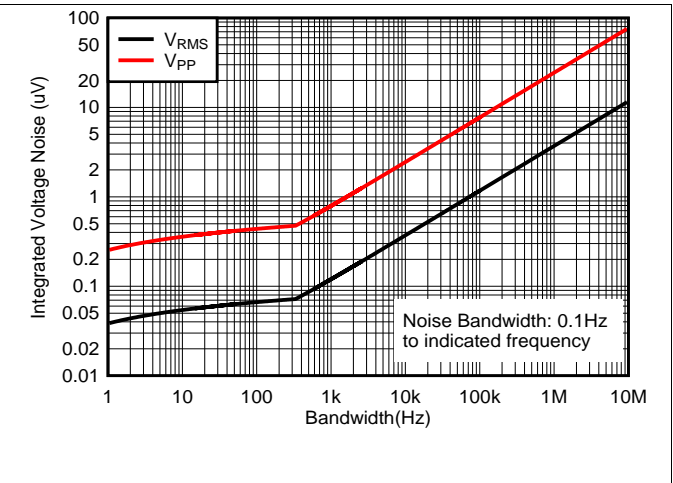

Figure 2. Integrated Input Voltage Noise vs Bandwidth

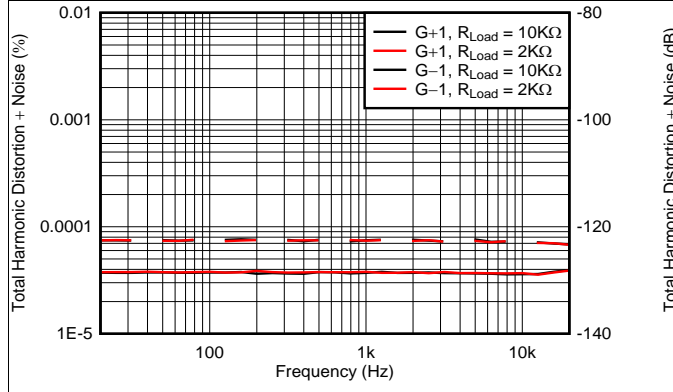

Figure 3. Total Harmonic Distortion + Noise Ratio vs Frequency

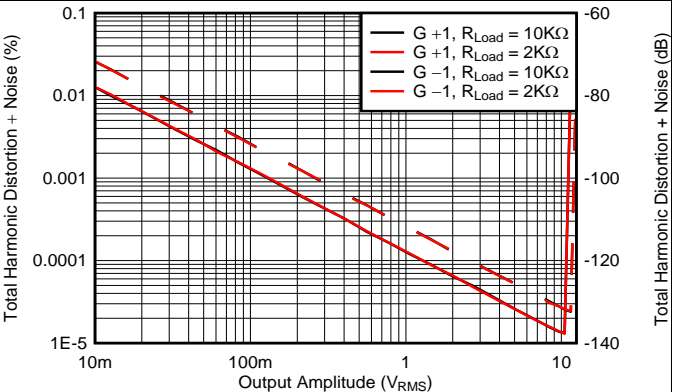

Figure 4. Total Harmonic Distortion + Noise Ratio vs Output Amplitude

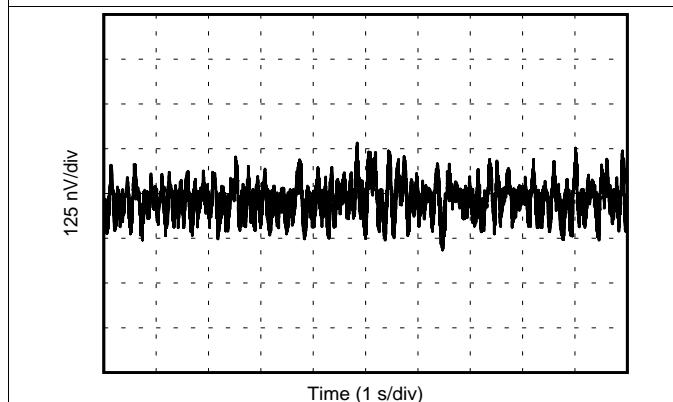

Figure 5. 0.1-Hz To 10-Hz Noise

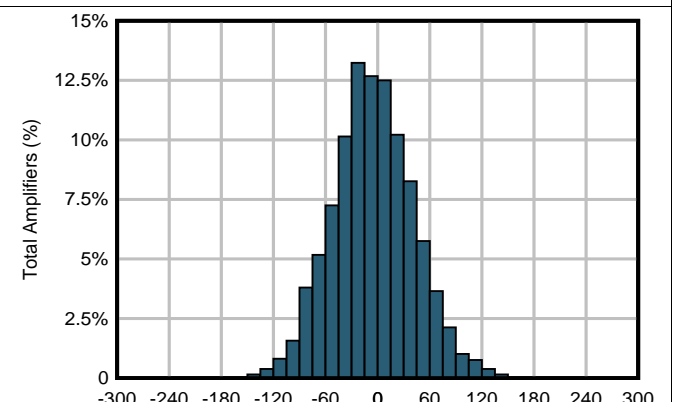

Figure 6. Offset Voltage Production Distribution

At  $T_A = 25^\circ\text{C}$ ,  $R_L = 2\text{ k}\Omega$  connected to midsupply, and  $V_{CM} = V_{OUT} = \text{midsupply}$ ,  $V_S = \pm 18\text{V}$ , unless otherwise noted.

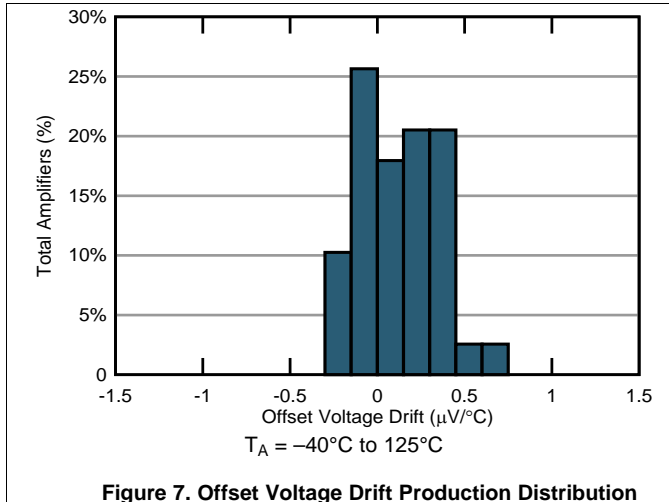

Figure 7. Offset Voltage Drift Production Distribution

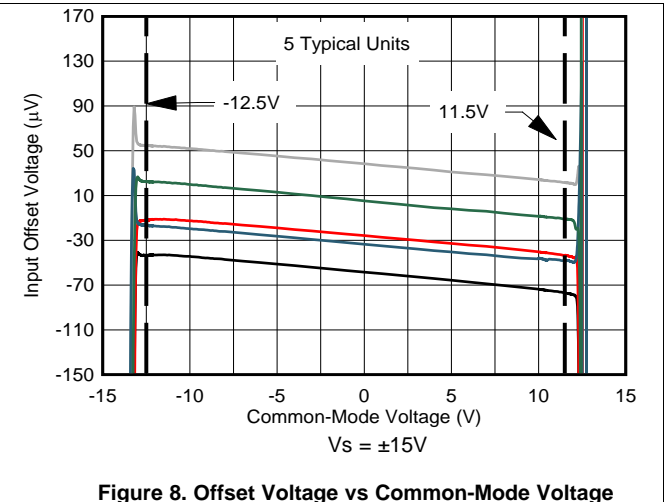

Figure 8. Offset Voltage vs Common-Mode Voltage

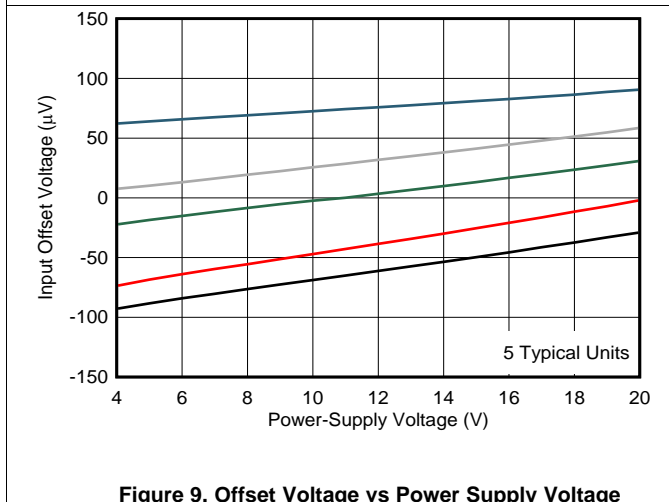

Figure 9. Offset Voltage vs Power Supply Voltage

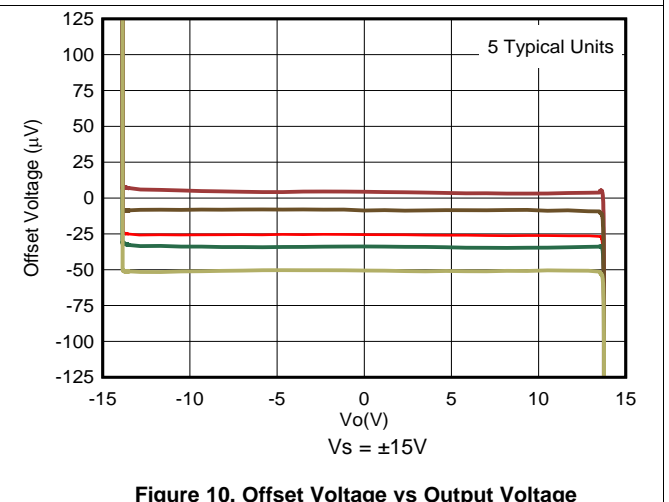

Figure 10. Offset Voltage vs Output Voltage

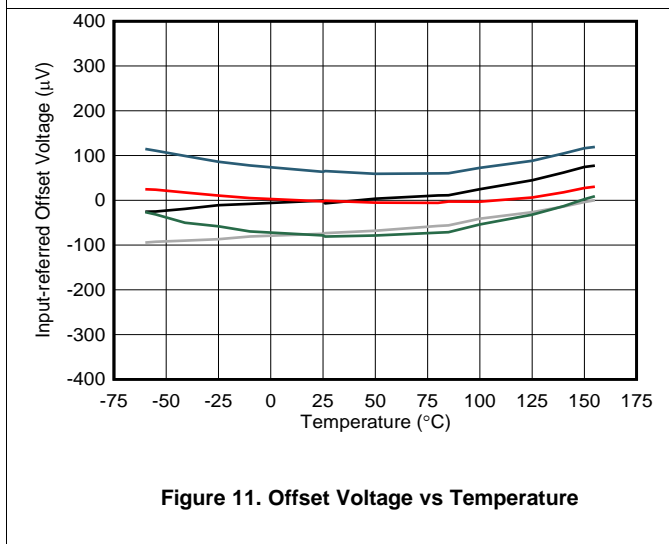

Figure 11. Offset Voltage vs Temperature

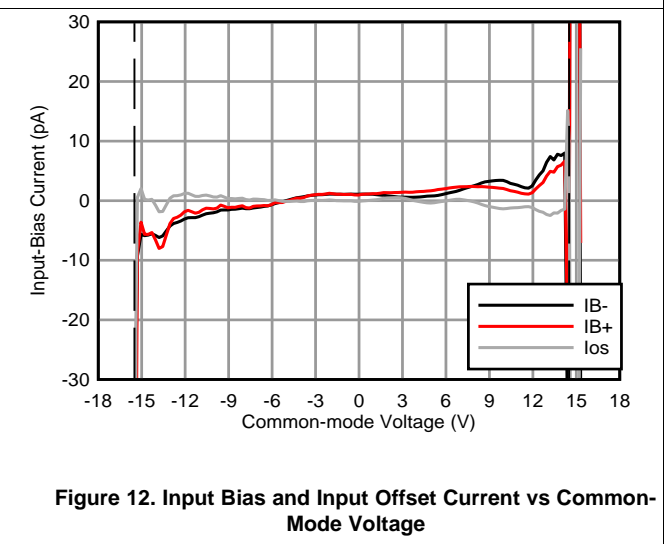

Figure 12. Input Bias and Input Offset Current vs Common-Mode Voltage

At  $T_A = 25^\circ\text{C}$ ,  $R_L = 2\text{ k}\Omega$  connected to midsupply, and  $V_{CM} = V_{OUT} = \text{midsupply}$ ,  $V_s = \pm 18\text{V}$ , unless otherwise noted.

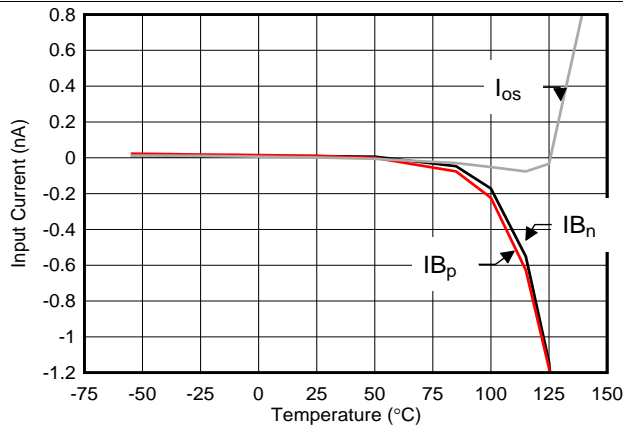

Figure 13. Input Bias and Input Offset Current vs Temperature

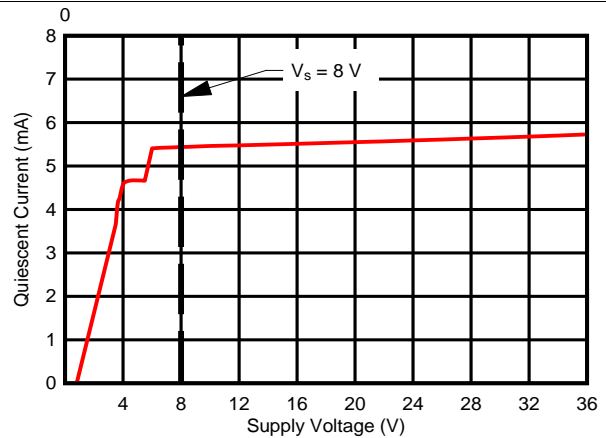

Figure 14. Quiescent Current vs Output Voltage

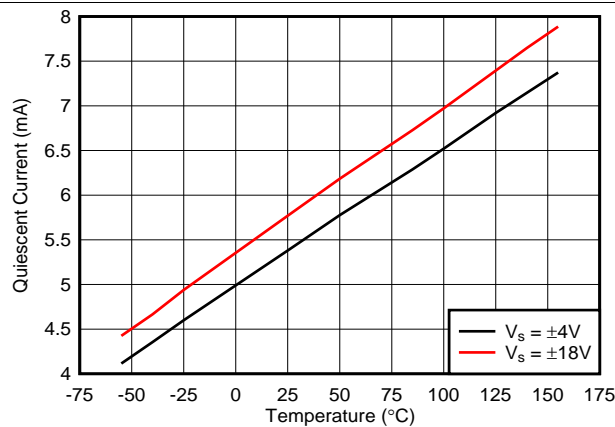

Figure 15. Quiescent Current vs Temperature

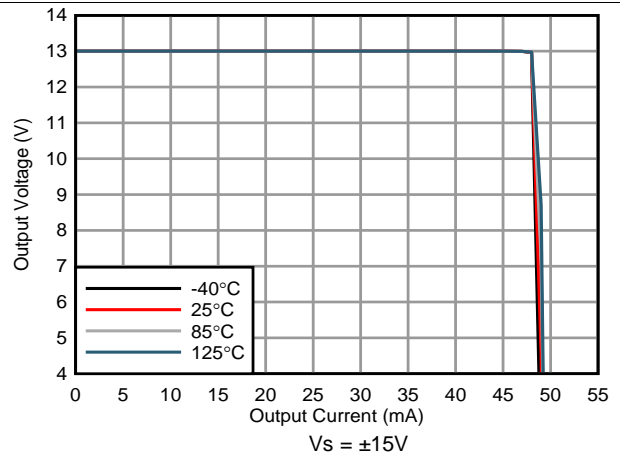

Figure 16. Output Voltage Swing vs Output Sourcing Current

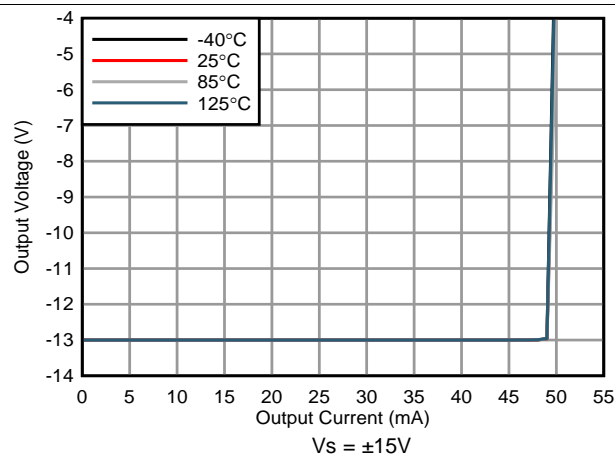

Figure 17. Output Voltage Swing vs Output Sinking Current

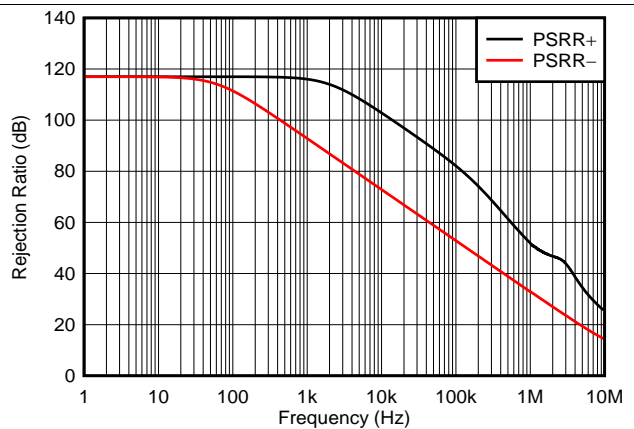

Figure 18. Power-Supply Rejection Ratio vs Frequency

At  $T_A = 25^\circ\text{C}$ ,  $R_L = 2\text{ k}\Omega$  connected to midsupply, and  $V_{CM} = V_{OUT} = \text{midsupply}$ ,  $V_S = \pm 18\text{V}$ , unless otherwise noted.

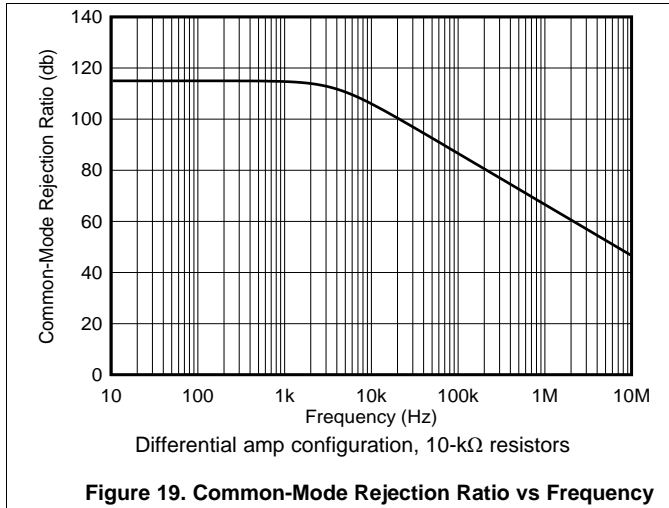

Figure 19. Common-Mode Rejection Ratio vs Frequency

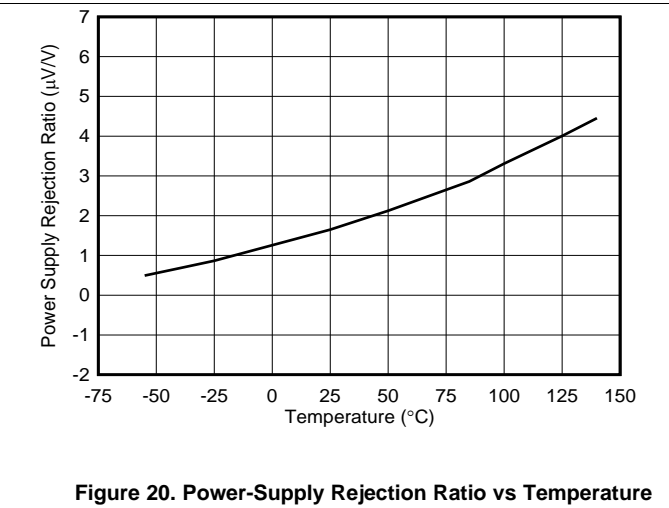

Figure 20. Power-Supply Rejection Ratio vs Temperature

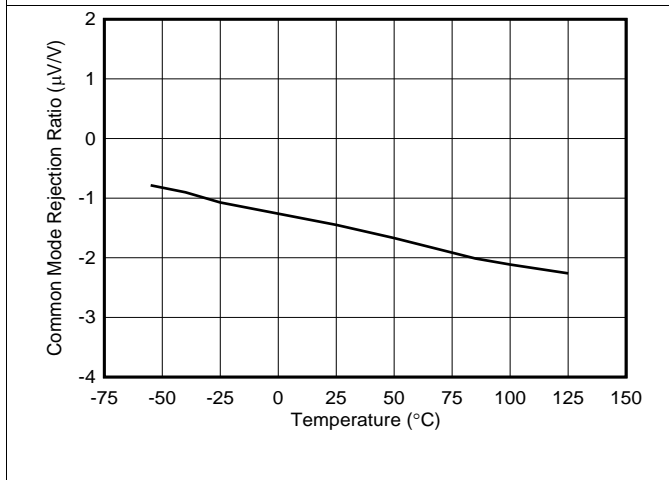

Figure 21. Common-Mode Rejection Ratio vs Temperature

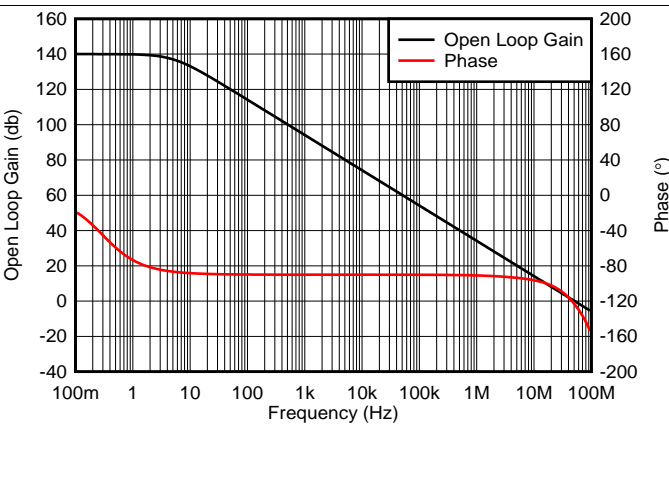

Figure 22. Open-Loop Gain and Phase vs Frequency

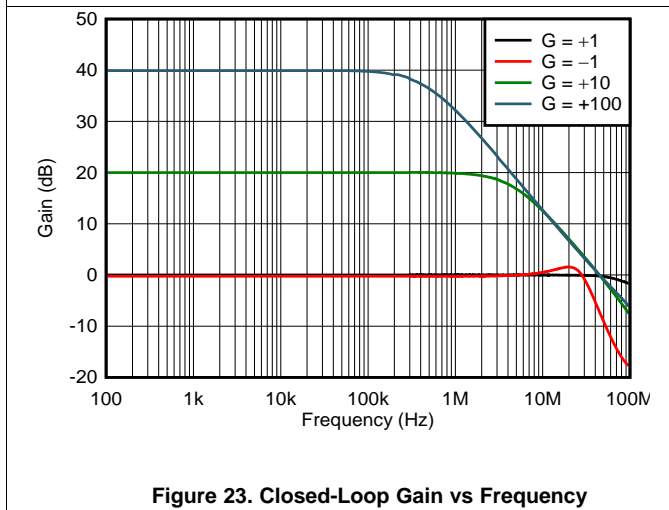

Figure 23. Closed-Loop Gain vs Frequency

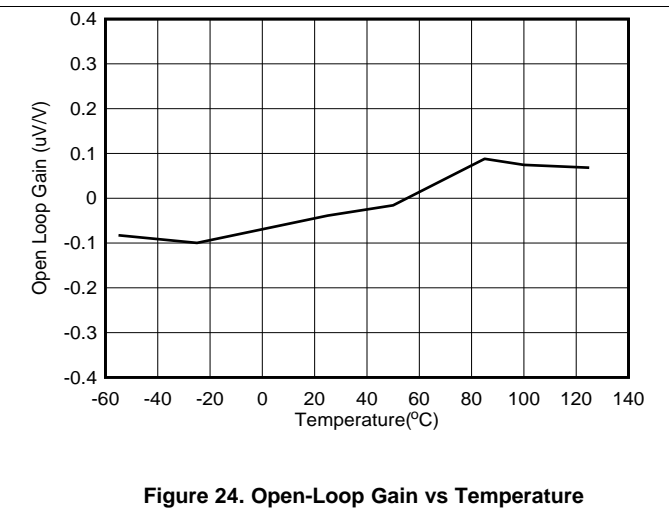

Figure 24. Open-Loop Gain vs Temperature

At  $T_A = 25^\circ\text{C}$ ,  $R_L = 2\text{ k}\Omega$  connected to midsupply, and  $V_{CM} = V_{OUT} = \text{midsupply}$ ,  $V_s = \pm 18\text{V}$ , unless otherwise noted.

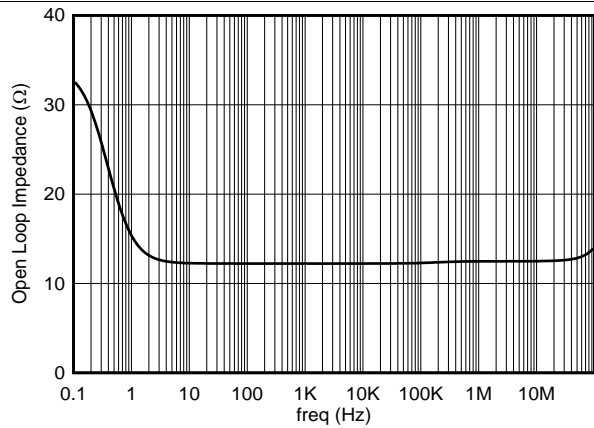

Figure 25. Open-Loop Output Impedance vs Frequency

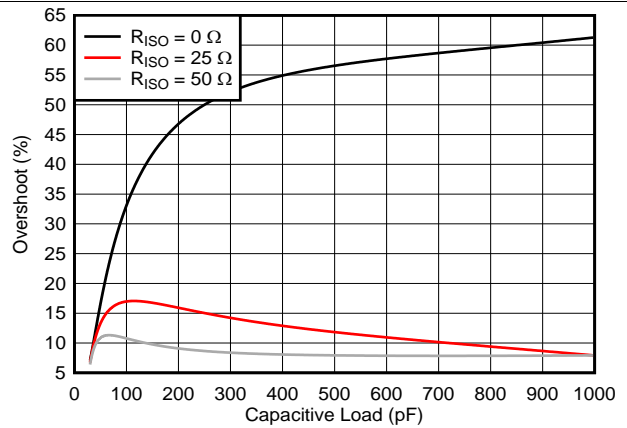

Figure 26. Small-Signal Overshoot vs Capacitive Load, Gain = +1

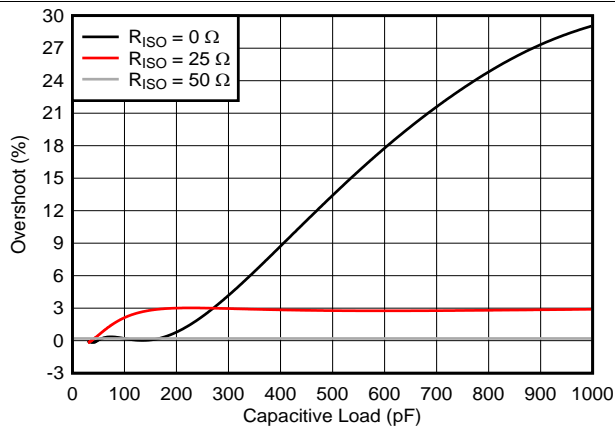

Figure 27. Small-Signal Overshoot vs Capacitive Load, Gain = -1

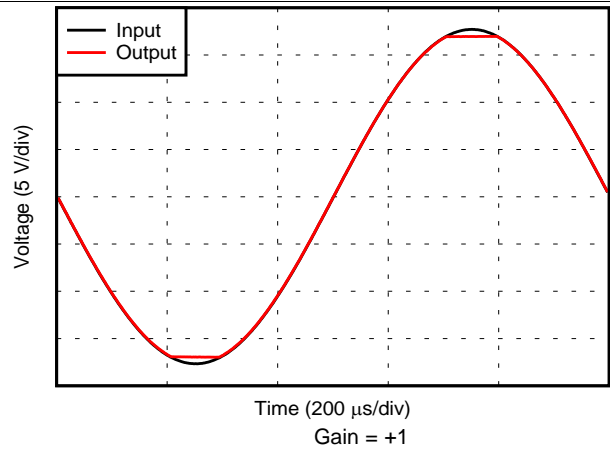

Figure 28. No Phase Reversal

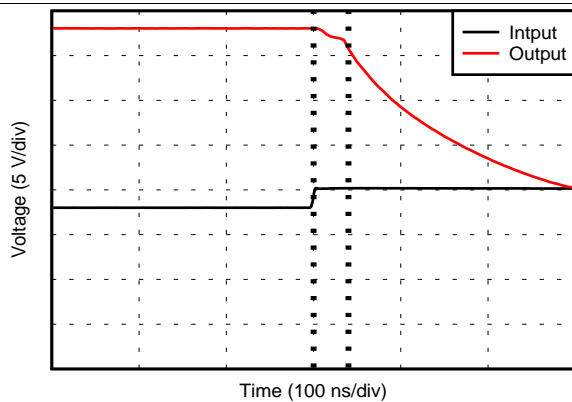

Figure 29. Positive Overload Recovery

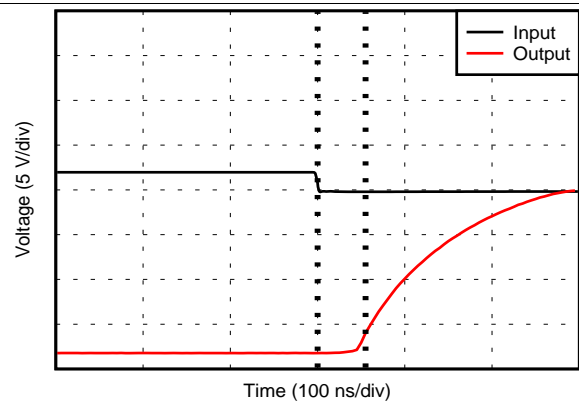

Figure 30. Negative Overload Recovery

At  $T_A = 25^\circ\text{C}$ ,  $R_L = 2\text{ k}\Omega$  connected to midsupply, and  $V_{CM} = V_{OUT} = \text{midsupply}$ ,  $V_s = \pm 18\text{V}$ , unless otherwise noted.

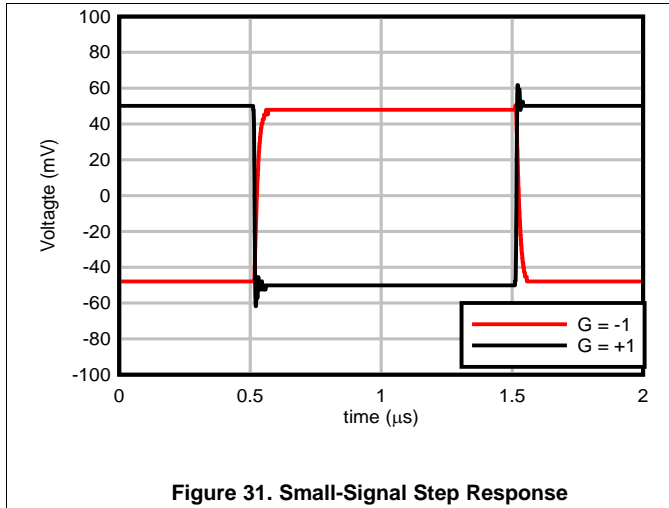

Figure 31. Small-Signal Step Response

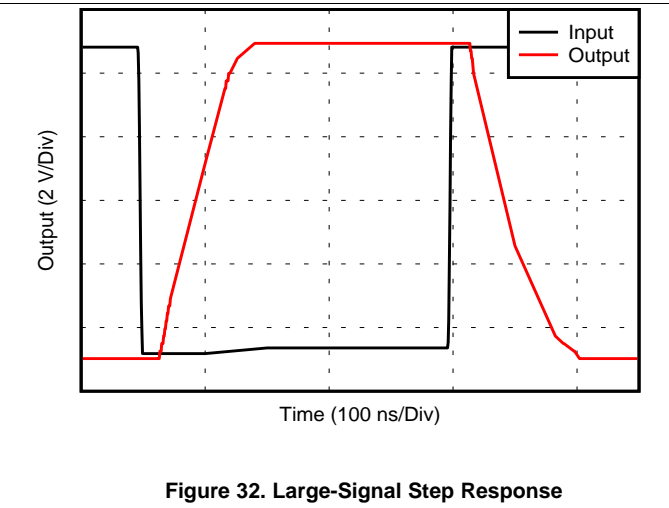

Figure 32. Large-Signal Step Response

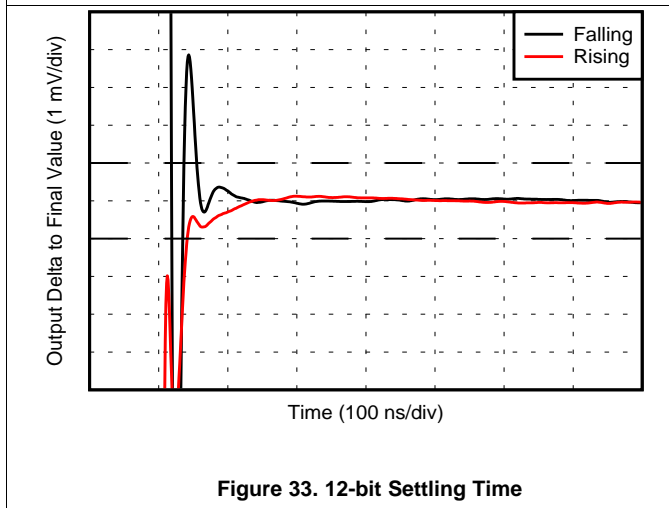

Figure 33. 12-bit Settling Time

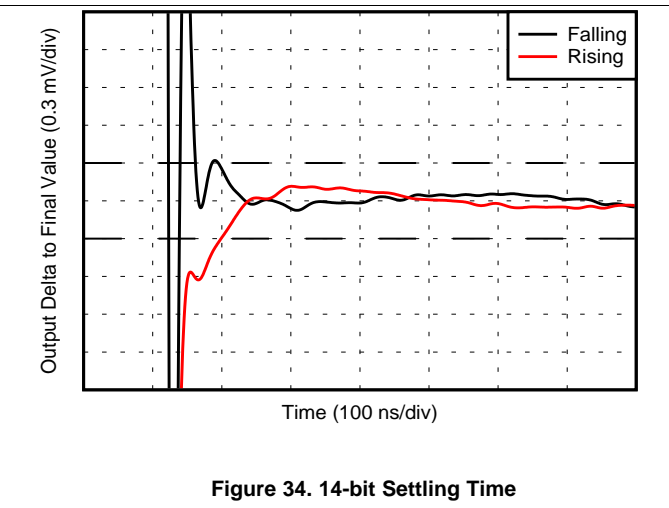

Figure 34. 14-bit Settling Time

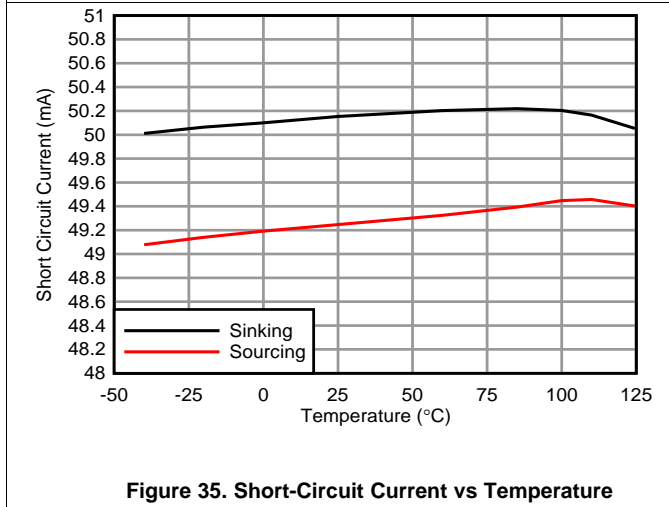

Figure 35. Short-Circuit Current vs Temperature

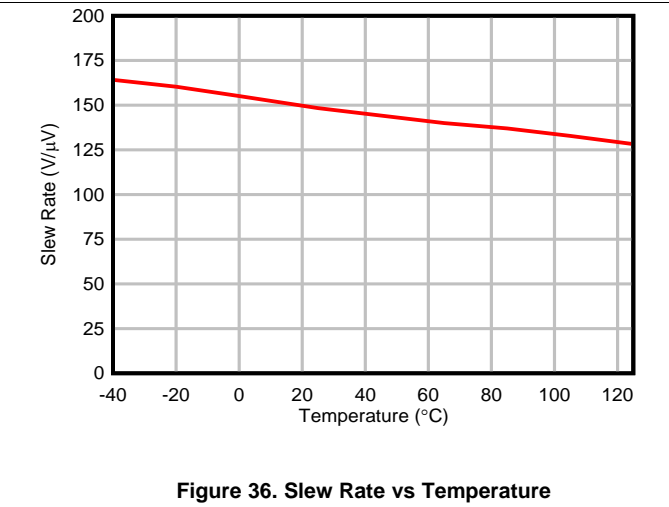
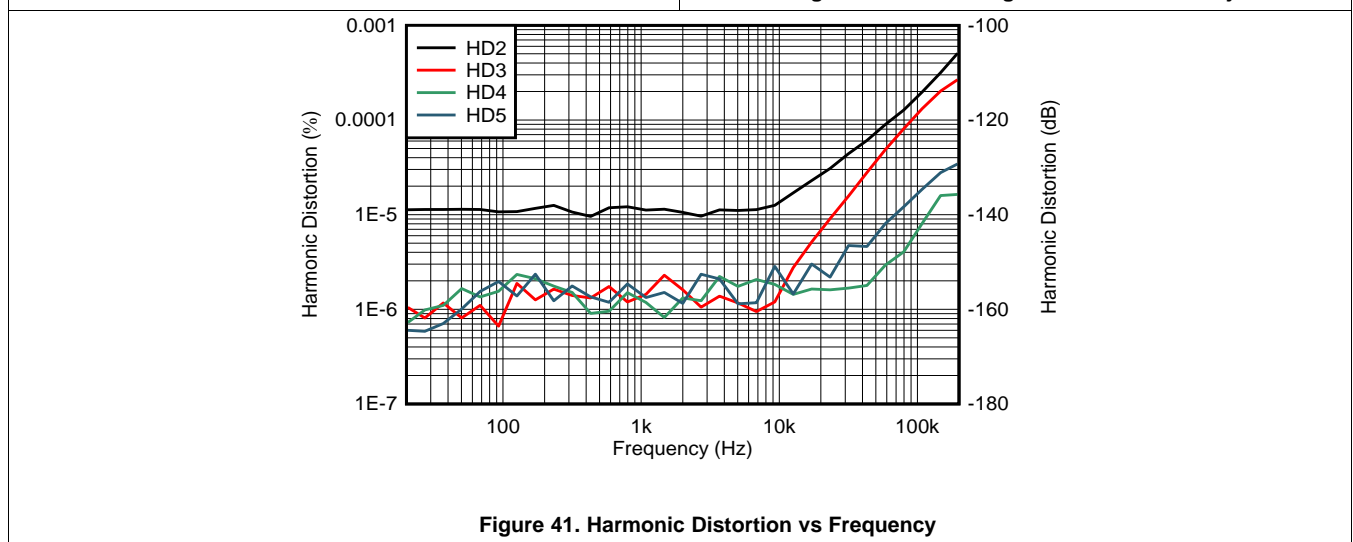
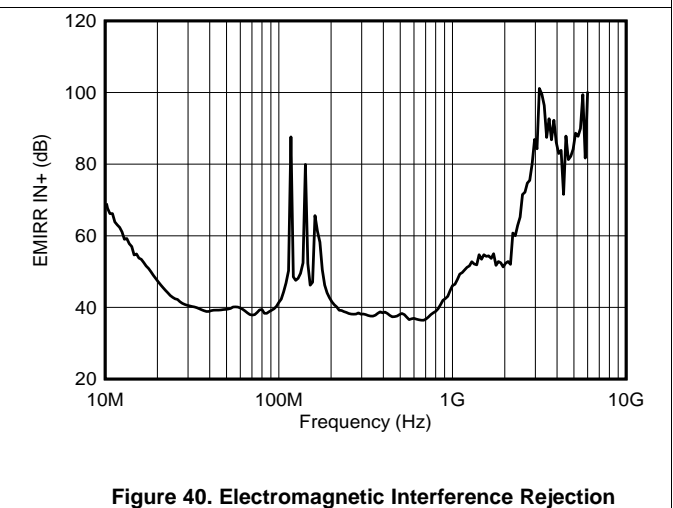
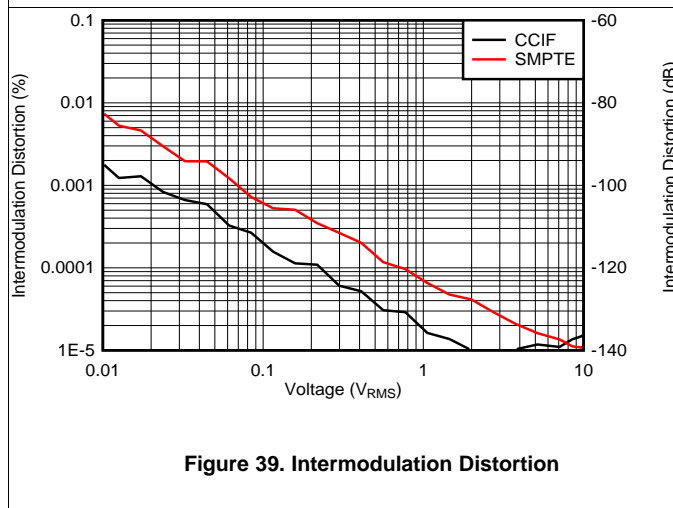
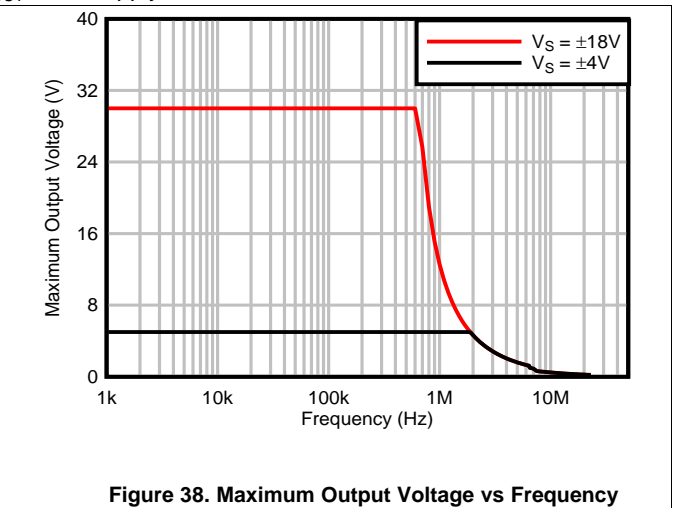
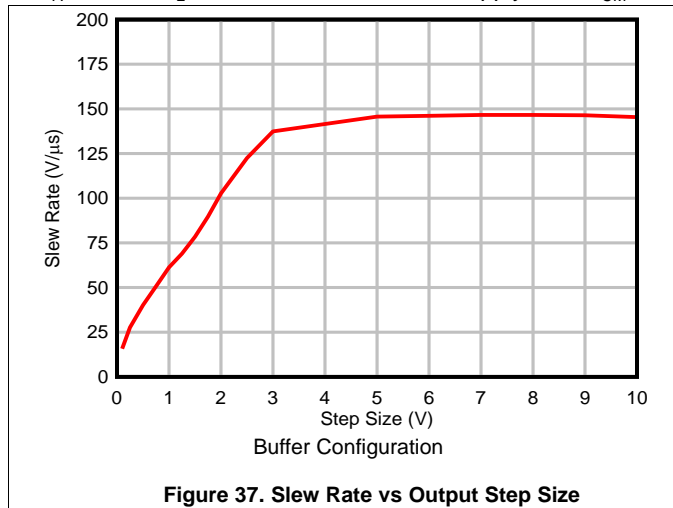

Figure 36. Slew Rate vs Temperature

At  $T_A = 25^\circ\text{C}$ ,  $R_L = 2\text{ k}\Omega$  connected to midsupply, and  $V_{CM} = V_{OUT} = \text{midsupply}$ ,  $V_S = \pm 18\text{V}$ , unless otherwise noted.



## 7 Detailed Description

### 7.1 Overview

The OPA828 is a low-noise, high-speed JFET input amplifier providing the highest levels of precision and accuracy. Each device is laser trimmed in production to ensure the lowest input referred offset voltage. Likewise, input referred offset voltage drift is trimmed and guaranteed over the specified junction temperature range from  $-40^{\circ}\text{C}$  to  $+125^{\circ}\text{C}$ . Additionally each device has its quiescent current laser trimmed to minimize part-to-part variations for dynamic parameters such as input referred noise voltage, gain-bandwidth product, slew rate, and settling time. The combination of low-noise, DC precision, and dynamic performance of the OPA828 is unsurpassed in the industry with the OPA828 taking full advantage of the latest and most advanced high-voltage, SiGe-complementary, JFET/bipolar process technology.

### 7.2 Functional Block Diagram

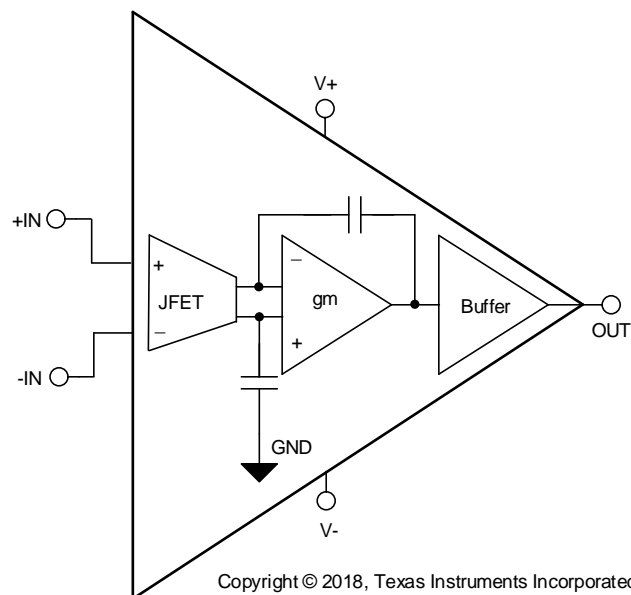



## 7.3 Feature Description

### 7.3.1 Operating Characteristics

The OPA828 operational amplifier is specified for operation from 8 V to 36 V ( $\pm 4$  V to  $\pm 18$  V). Many of the specifications apply from  $-40^{\circ}\text{C}$  to  $+125^{\circ}\text{C}$ . Parameters that can exhibit significant variance with regard to operating voltage or temperature are shown in [Typical Characteristics](#).

### 7.3.2 Phase-Reversal Protection

Many operational amplifiers exhibit a phase reversal when the input drives beyond their specified input common-mode range. This condition is most often encountered in non-inverting circuits when the input drives beyond the specified common-mode voltage range, which can cause the output to reverse into the opposite rail. The OPA828 has an internal phase-reversal protection circuitry. The input architecture of the OPA828 prevents phase reversal with input common-mode voltages that exceed the specified maximum and minimum values. The OPA828 output limits to the appropriate rail. This performance is shown in [Figure 42](#). When input voltages can exceed the minimum or maximum specified limits, care must be taken to limit the maximum input current through internal ESD protection diodes.

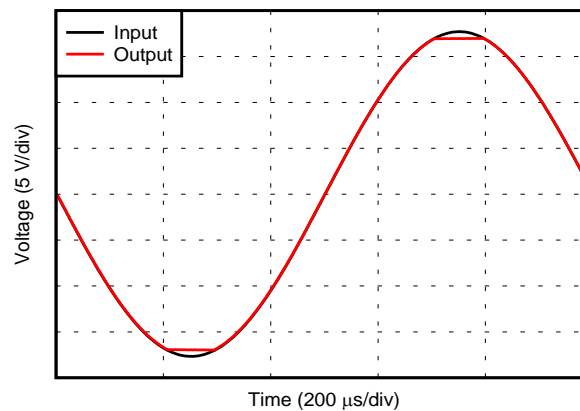
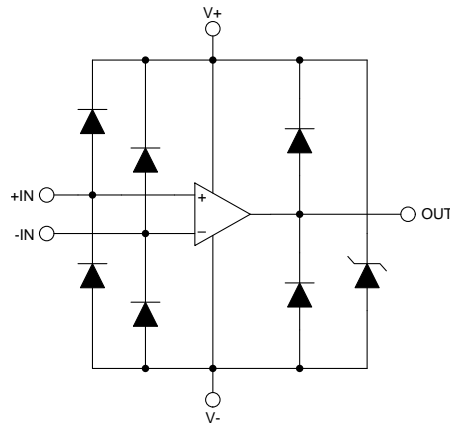

Figure 42. No Phase Reversal

### 7.3.3 Electrical Overstress

The OPA828 is internally protected against ESD events which can occur during manufacturing, handling, or printed-circuit-board assembly. The internal ESD protection diodes are not intended to protect the OPA828 during normal operation when the device is operating under power. The ESD protection circuitry involves several current-steering diodes connected from the input and output pins and routed back to the internal power-supply lines, where the diodes meet at the power-supply ESD cell, an absorption device, internal to the operational amplifier. This protection circuitry is intended to remain inactive during normal circuit operation. In cases where the inputs or output can be driven above the positive power supply or below the negative power supply care must be taken to limit the current through the internal diodes to 10 mA or less. In harsh electrical environments external protection circuitry may be required and is dependant upon the application requirements and environmental conditions.

## Feature Description (continued)



Copyright © 2018, Texas Instruments Incorporated

**Figure 43. Equivalent Internal ESD Circuitry**

One example of protecting the OPA828 inputs against an input over-voltage condition is illustrated in Figure 44. In this example the non-inverting input to the OPA828 is protected with the addition of an external resistor. If the input voltage,  $V_{IN}$ , exceeds either power supply voltage, the input ESD diodes become forward biased at approximately 0.5 V. It is recommended to limit the current through the forward-biased internal ESD diodes under such conditions; see [Absolute Maximum Ratings](#). In this specific example illustrated in Figure 44, the addition of the input resistor provides the necessary current limiting and allows for input voltages at  $V_{IN}$  up to  $\pm 25.5$  V. Assuming a symmetrical, dual power supply configuration, the maximum input voltage for this circuit configuration can be determined from Equation 1:

$$\pm |V_{IN}| = |V_S| + 0.5V + 10mA \times R_{IN} \quad (1)$$

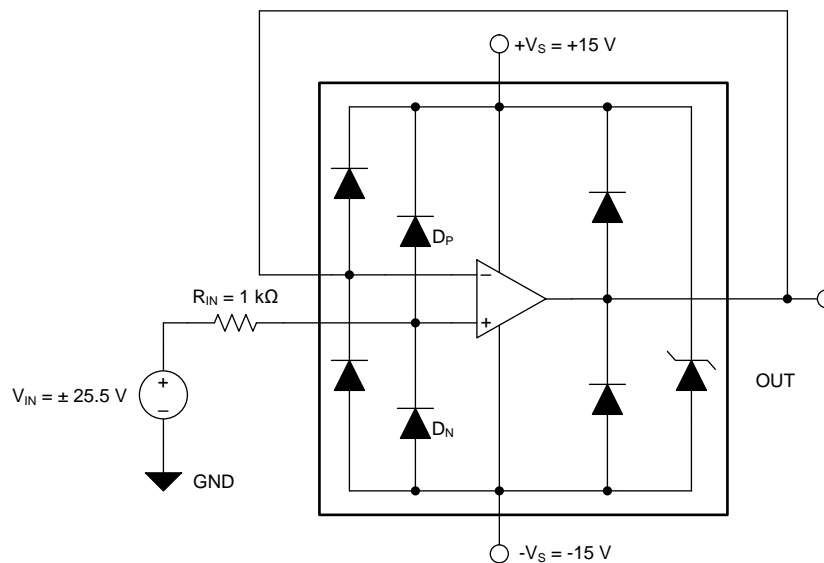

Copyright © 2018, Texas Instruments Incorporated

**Figure 44. Limiting the Input Current**

Adding the series input protection resistor as described above will add an additional source of noise to the circuit. Resistance values below 250  $\Omega$  contribute less than 10% of additional noise. A resistance value of 1 k $\Omega$  increases the noise by approximately by 40%. The OPA828 has an equivalent input noise resistance of approximately 1 k $\Omega$ .

## Feature Description (continued)

### 7.3.4 MUX Friendly Inputs

Multiplexing is a frequently-used technique to perform data acquisition in multi-channel systems with minimal signal-chain requirements. In this context, the role of the multiplexer (MUX) in an acquisition system is to switch between channels and send each signal as fast as possible to a single data converter — maximizing system throughput and minimizing delay. To ensure accurate processing, a precision amplifier is placed downstream from the multiplexer to precisely drive the analog-to-digital converter (ADC). This concept is illustrated in Figure 45.

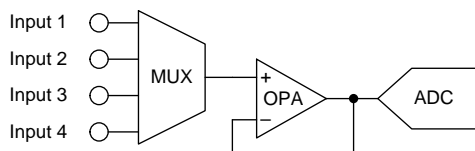

Copyright © 2018, Texas Instruments Incorporated

**Figure 45. Typical Multiplexed System Block Diagram**

In a typical multiplexed application it is common that large transient voltages can be presented to the input of the op amp driving the ADC. Large input differential voltages are commonly seen during slewing or open-loop operation, which is especially common when switching from one MUX input to another. Traditional precision amplifiers often consist of a differential transistor pair that is protected from large differential transient input voltages with anti-parallel diodes between the inputs of the amplifier. These anti-parallel diodes are effective at limiting the voltage differential between the inputs to one or two forward diode voltage drops, which protects the precision input devices from damage. However, the anti-parallel diodes do have considerable drawbacks such as large inrush currents when they are turned on. If passive filtering or high source impedance is present, large inrush current can disturb settling time, limiting the throughput of the system and degrading signal-chain precision. The OPA828 does not need anti-parallel diodes to protect the input JFET transistors and is free from large inrush currents even with differential input voltages as large as  $\pm 18$  V. These concepts are illustrated in Figure 46:

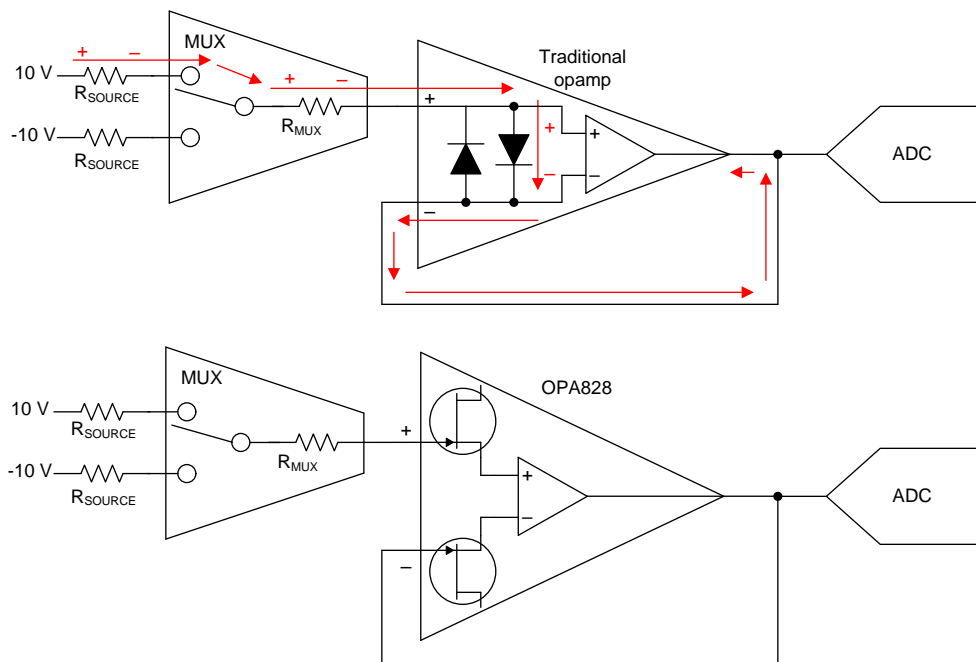

Copyright © 2018, Texas Instruments Incorporated

**Figure 46. Typical Multiplexed System Block Diagram**

## Feature Description (continued)

### 7.3.5 Overload Power Limiter

In many applications, tight limits on opamp power consumption exist and it is therefore highly desirable that the amplifier's power consumption remains constant even during fault conditions, such as a large voltage across the inputs or the output hitting the rail. In particular, high slew-rate amplifiers, such as the OPA828 temporarily increase the supply current when the amplifier is slewing. In slew-boosted amplifiers, the presence of a large input signal can present a specific problem, since it applies a large voltage across the amplifier's inputs. This will activate the slew-boost and can lead to a significant increase in current consumption. In addition, at high supply voltages the large current consumption can lead to significant amplifier self-heating.

OPA828 offers a high slew rate of 150 V/us in combination with a comparably low supply current of 5.5 mA. Like many other amplifiers, this is achieved by a so called slew-boosting method, which temporarily increases the amplifier's current consumption when the amplifier is slewing. Such a slewing condition is detected by measuring the voltage across the input pins. In quiescent condition, this voltage is very small (equal to the amplifier's offset). If, on the other hand, an input voltage is changed rapidly, a large voltage will be applied across the inputs and the amplifier output needs to slew. On OPA828, the supply current increase is gradual and proportional to the applied input voltage, ensuring a well-behaved large step response and excellent THD. Because the high slew rate ensures the output re-settles in less than about 300ns, the increased power consumption is absorbed by the decoupling capacitors, and therefore does not additionally load the power supplies.

In OPA828, such an increase in current consumption is avoided by an additional protection circuit, which continuously monitors both the amplifier's inputs and output. If a large input voltage is detected, the protection circuit checks for the presence of a rapid change in voltage at the output. If the output voltage is not changing, for instance because the output is at a supply rails, the protection circuit will disable the slew-boost circuit after a delay of about 300ns. After the overload condition is removed, the amplifier rapidly recovers to a normal operating condition. This is indicated in [Figure 47](#), where the amplifiers supply current is measured with its decoupling capacitors removed. It can be observed that after 300 ns, the power consumption of the amplifier goes back to quiescent levels. At the same time, the amplifier still has an excellent overload recovery time of less than 55 ns.

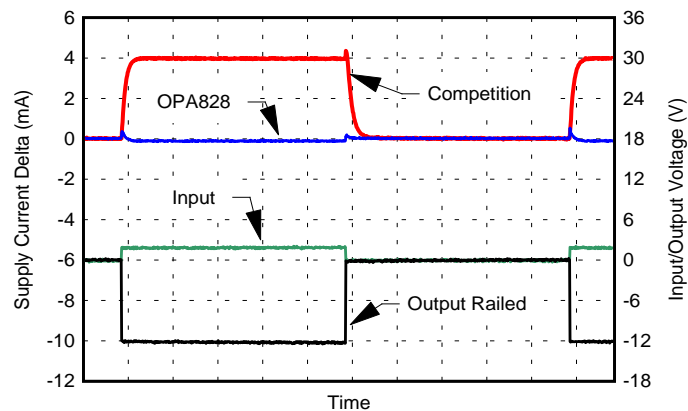

**Figure 47. Supply Current Change with Overloaded Output**

### 7.3.6 Capacitive Load and Stability

[Figure 48](#) shows the total circuit noise for varying source impedances with the operational amplifier in a unity-gain configuration (with no feedback resistor network and therefore no additional noise contributions). The OPA828 and OPA211 are shown with total circuit noise calculated. The op amp itself contributes both a voltage noise component and a current noise component. The voltage noise is commonly modeled as a time-varying component of the offset voltage. The current noise is modeled as the time-varying component of the input bias current and reacts with the source resistance to create a voltage component of noise. Therefore, the lowest noise

### Feature Description (continued)

op amp for a given application depends on the source impedance. For low source impedance, current noise is negligible, and voltage noise generally dominates. The OPA828 device has both low voltage noise and extremely low current noise because of the FET input of the op amp. As a result, the current noise contribution of the OPA828 is negligible for any practical source impedance, which makes it the better choice for applications with high source impedance.

The equation in shows the calculation of the total circuit noise, with these parameters:

- $e_n$  = voltage noise
- $i_n$  = current noise
- $R_S$  = source impedance
- $k$  = Boltzmann's constant =  $1.38 \times 10^{-23}$  J/K
- $T$  = temperature in degrees Kelvin (K)

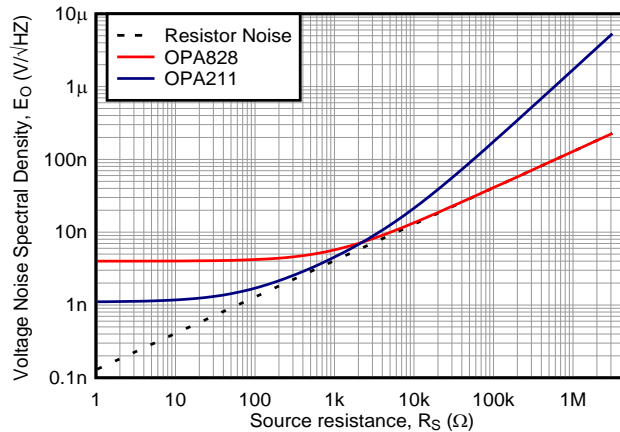

Figure 48. Noise Performance of the OPA828 and OPA211 in Unity-Gain Buffer Configuration

### 7.3.7 Capacitive Load and Stability

The dynamic characteristics of the OPA828 are optimized for common operating conditions. The combination of low closed-loop gain and high capacitive loads decreases the phase margin of the amplifier and can lead to gain peaking or oscillations. As a result, heavier capacitive loads must be isolated from the output. The simplest way to achieve this isolation is to add a small resistor (for example,  $R_{OUT}$  equal to  $50 \Omega$ ) in series with the output. The Figure 49 graph show small-signal overshoot versus capacitive load. See [Feedback Plots Define Op Amp AC Performance](#) for details of analysis techniques and application circuits.

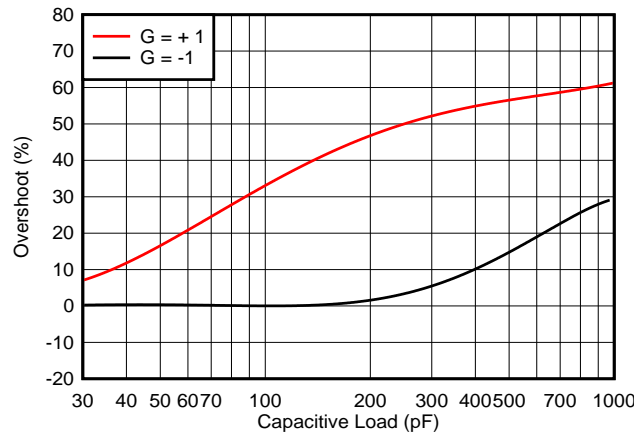
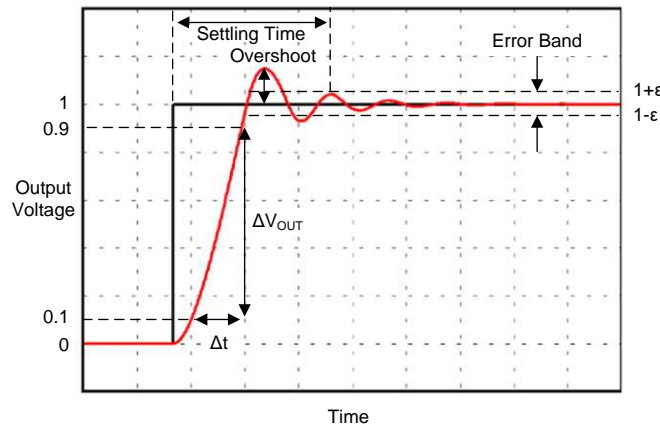

Figure 49. Small-Signal Overshoot vs Capacitive Load

## Feature Description (continued)

### 7.3.8 Settling Time

Settling time is a measure of an amplifiers output to settle to within some percentage (error band) of the input amplitude and is used to describe an amplifiers response to a step input. An amplifiers settling time is comprised of both a large signal response and small signal response. The large signal response is characterized by the rise and fall times while the small signal response is characterized by overshoot and ringing. Figure 50 illustrates the concepts and terminology associated with an amplifiers settling time. Specifically the settling time is defined as the time it takes the output to settle to within a specified error band from the time the input signal was applied.



**Figure 50. Settling Time**

The OPA828 minimizes settling time for high-resolution systems by incorporating an internal slew boost circuit which minimizes rise and fall times and having wide bandwidth with excellent phase margin with low ringing, enabling small signal settling in minimal time. The OPA828 is trimmed in laser production that will minimize part-to-part variation in the device slew rate, bandwidth and phase margin thus mainlining excellent unit-to-unit variations across all manufacturing lots.

### 7.3.9 Slew Rate

The parameter of an amplifier that best describes the large signal dynamic behavior is the slew rate. Slew rate is a measure the maximum rate of change of the output voltage with respect to time and is generally expressed in units of volts-per-microsecond, (V/μs). Typically the slew rate is measured as the time it takes for the output to swing from 10% of its final value to 90% of its final value. The slew rate for the signal illustrated in Figure 50 is given by Equation 2.

$$Slew\ Rate = \frac{\Delta V_{OUT}}{\Delta t} = \frac{(V_{OUT_{90}} - V_{OUT_{10}})}{(t_{90} - t_{10})} \quad (2)$$

The slew rate of an amplifier is limited by the internal architecture of the amplifier, the amplifiers quiescent power and internal capacitances. The OPA828 maximizes slew rate by incorporating a slew-boost circuit. The proprietary slew boost circuit used in the OPA828 results in a very high slew rate while maintaining low quiescent power levels. The internal slew boost circuit measures the input differential voltage present between +IN and –IN input pins. If this input differential voltage is sufficiently large enough, the internal slew boost circuit increases the internal biasing currents of the amplifier thereby increasing the ability of the output to slew faster. TI recommends placing power supply bypass capacitors close to the OPA828 to make sure of optimum dynamic performance.

Should the inputs of the amplifier have a large static or DC differential voltage present, the OPA828 recognizes that condition, not as an indicator of the need to slew faster, but rather as an overload condition. In this case the OPA828 internal biasing currents do not increase, and the quiescent current remains unchanged from normal operation.

## Feature Description (continued)

### 7.3.10 Full Power Bandwidth

The full power bandwidth of an amplifier describes the frequency at which the largest sinusoidal signal the amplifier can provide at its output before slew rate induced distortion becomes a dominant source of error. This concept is illustrated in Figure 51.

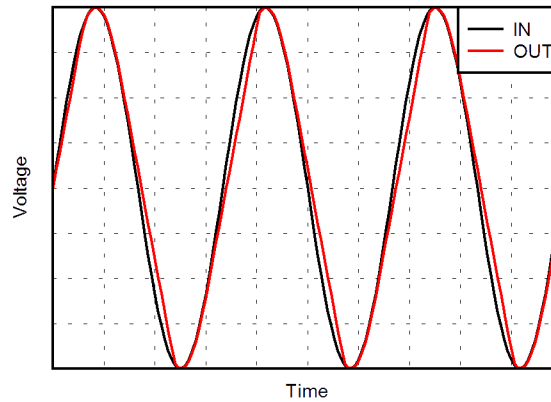

Figure 51. Slew Rate Induced Distortion

If the inputs of the amplifier are driven too far apart, such as when a multiplexer connected to the inverting input changes channels, a slew boost circuit is enabled to help settling time but can distort the signal. If low distortion is needed, avoid driving the inputs too far apart from each other. The OPA828 has a full power bandwidth of 1.2 MHz with  $10 \cdot V_{PEAK}$  output voltage. The maximum output voltage as a function of frequency is illustrated in Figure 52.

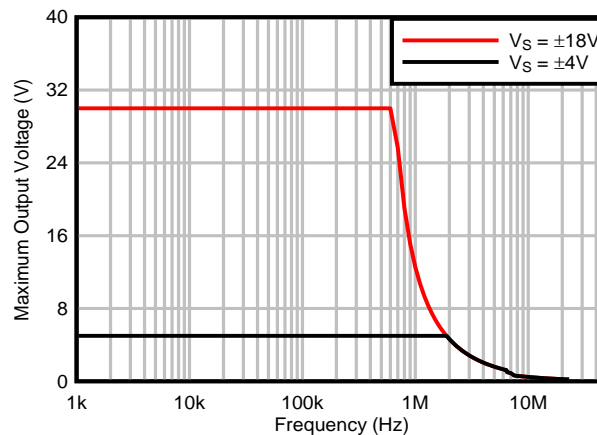

Figure 52. Maximum Output Voltage vs Frequency

### 7.3.11 Small Signal Response

The parameters of an amplifier that best describes the small signal dynamic behaviour are the gain-bandwidth product (GBP), unity gain frequency (UGF) and phase margin (PM) of an amplifier. The GBP is a useful parameter to determine the bandwidth of an application in closed loop configurations. Equation 3 can be used to approximate the closed loop bandwidth for the OPA828. Typically the GBP is a specified parameter with the amplifier configured in a non-inverting gain of 100 (40 dB). The GBP of an amplifier is generally assumed to be constant over frequency but in some higher speed amplifiers this is not always the case. The OPA828 has a constant GBP all the way to its UGF, as such the OPA828 open-loop gain has a constant  $-20$  dB/decade slope ( $-6$  dB/octave). The UGF is defined as the frequency at which the gain of the amplifier crosses  $1V/V$  (0 dB). Figure 53 illustrates the concept of GBP and UGF. The OPA828 has both a GBP and UGF of 45 MHz.

## Feature Description (continued)

$$\text{Bandwidth} = \frac{GBP}{A_{CL}} = \frac{45\text{MHz}}{A_{CL}} \quad (3)$$

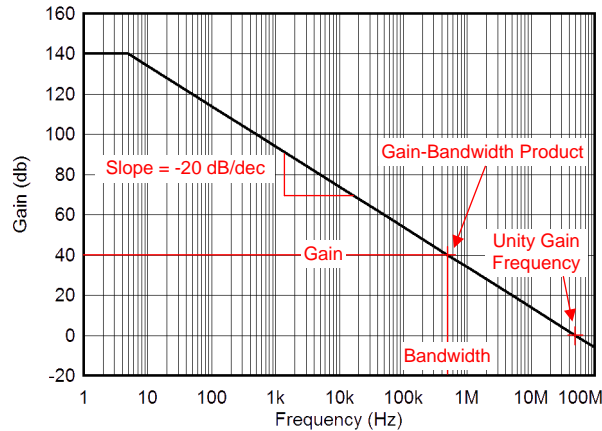

**Figure 53. Gain-Bandwidth Product and Unity Gain Frequency**

### 7.3.12 Thermal Considerations

Through normal operation the OPA828 experiences self-heating, a natural increase in the die junction temperature which occurs in every amplifier. This is a result of several factors including the quiescent power consumption, the package's thermal resistance, PCB layout and the device operating conditions.

To fully ensure the amplifier will operate without entering thermal shutdown it is important to calculate the approximate junction (die) temperature which can be done using [Equation 4](#).

$$T_j = P_D * \Theta_{JA} + T_A \quad (4)$$

[Equation 5](#) shows the approximate junction temperature for the OPA828 while unloaded with an ambient temperature of 25°C.

$$T_j = (36V * 5.5mA) * 121.5^\circ C / W + 25^\circ C$$

$$T_j = 49^\circ C \quad (5)$$

For high voltage, high precision amplifiers such as the OPA828 the junction temperature can easily be 10s of degrees higher than the ambient temperature in a quiescent (unloaded) condition. If the device then begins to drive a heavy load the junction temperature may rise and trip the thermal shutdown circuit. The [Figure 54](#) shows the maximum output voltage of the OPA828 without entering thermal shutdown vs ambient temperature in both a loaded and unloaded condition.



## Feature Description (continued)

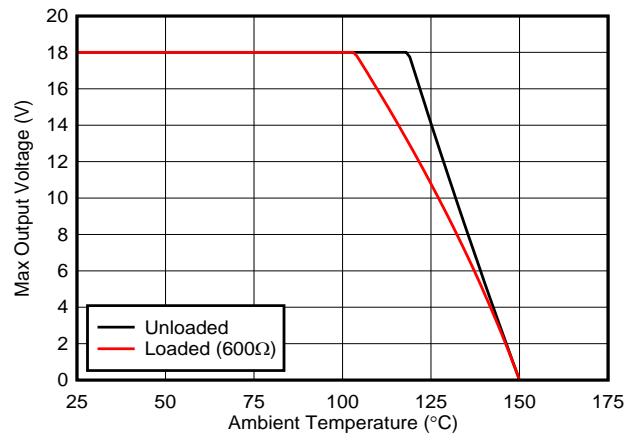

Figure 54. OPA828 Thermal Safe Operating Area

### 7.3.13 Thermal Shutdown

The OPA828 is protected from thermal overloads due to an internal thermal shutdown feature. The shutdown design assures thermal protection when operated in demanding, high-temperature industrial environments. The device accurately measures the die junction temperature at the hottest spot on the die. As the junction temperature reaches the thermal shutdown temperature the device is disabled by placing the output into a high impedance state — this prevents further power dissipation by the OPA828 and allows the OPA828 to begin cooling. Once the junction temperature reduces by the thermal hysteresis amount, the OPA828 resumes normal operation. If the output condition that caused the OPA828 to heat up is still present the device may enter thermal shutdown again. The OPA828 quiescent current during shutdown reduces to approximately 20  $\mu$ A. Identify the cause of any thermal shutdown, and correct for normal device operation. Thermal shutdown occurs when the OPA828 junction temperature exceeds approximately 165°C. Once in thermal shutdown, the OPA828 returns to normal operation when the junction temperature cools to approximately 145°C.

### 7.3.14 Low Noise

The OPA828 is fabricated on a state-of-the-art SiGe Precision, High-Speed, High-Voltage, BiFET wafer process. Patented wafer processing techniques are used to reduce the noise associated with the JFET gate regions. The OPA828 noise spectral density is shown in Figure 55.

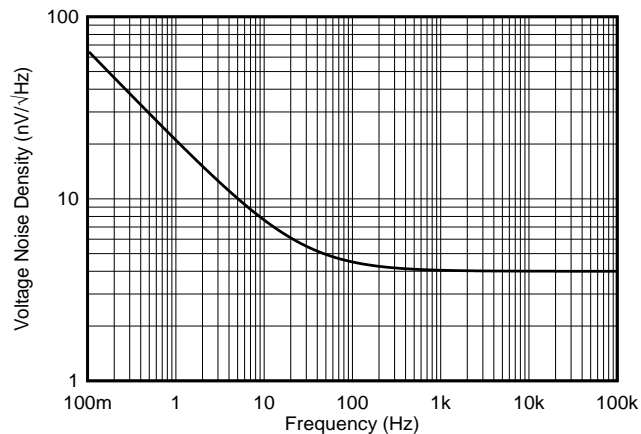
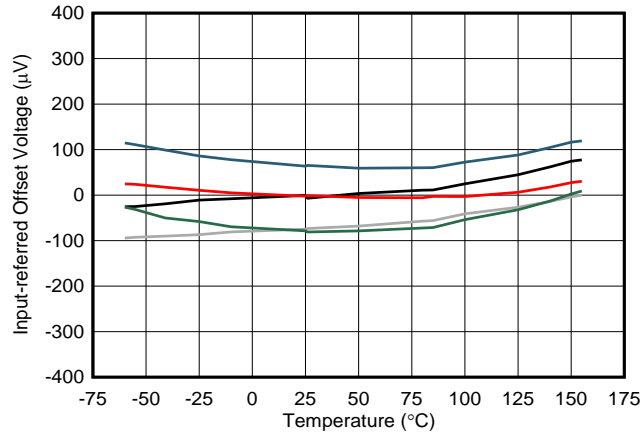

Figure 55. Noise Spectral Density vs Frequency

## Feature Description (continued)

### 7.3.15 Low Offset Voltage Drift

Each OPA828 is laser trimmed in production. Input offset voltage is trimmed at two temperatures assuring low input offset voltage drift across the full temperature range.



**Figure 56. Input Offset Voltage vs Temperature**

### 7.3.16 Overload Recovery

Overload recovery is defined as the time required for the op amp output to recover from the saturated state to the linear state. The output devices of the op amp enter the saturation region when the output voltage exceeds the rated operating voltage resulting from the high input voltage or the high gain. After the device enters the saturation region, the charge carriers in the output devices must have time to return back to the normal state. After the charge carriers return back to the equilibrium state, the device begins to slew at the normal slew rate. As a result, the propagation delay (in case of an overload condition) is the sum of the overload recovery time and the slew time. The overload recovery time for the OPA828 is approximately 55 ns.

## 7.4 Device Functional Modes

### 7.4.1 Functional Modes

The OPA828 is operational when the applied power supply voltage is between  $\pm 4$  V and  $\pm 18$  V. When operating the OPA828 device self-heating occurs. Device self-heating is a function of the power-supply voltage and power delivered to the load. Under heavy loading conditions and elevated ambient temperatures the OPA828 may enter thermal shutdown. Thermal shutdown occurs when the OPA828 junction temperature exceeds approximately  $165^{\circ}\text{C}$ . Once in thermal shutdown, the OPA828 returns to normal operation when the junction temperature cools to approximately  $145^{\circ}\text{C}$ .

## 8 Application and Implementation

### NOTE

Information in the following applications sections is not part of the TI component specification, and TI does not warrant its accuracy or completeness. TI's customers are responsible for determining suitability of components for their purposes. Customers should validate and test their design implementation to confirm system functionality.

### 8.1 Application Information

The OPA828 combines low offset and offset drift with low noise across a wide bandwidth, making it well suited for a variety of test equipment and data acquisition systems.

### 8.2 Typical Applications

#### 8.2.1 Typical Application: SAR ADC Driver

The high DC precision and AC performance of the OPA828 along with the 45-MHz bandwidth enable it to quickly and accurately drive a 16-bit successive approximate register (SAR) analog-to-digital converter (ADC).

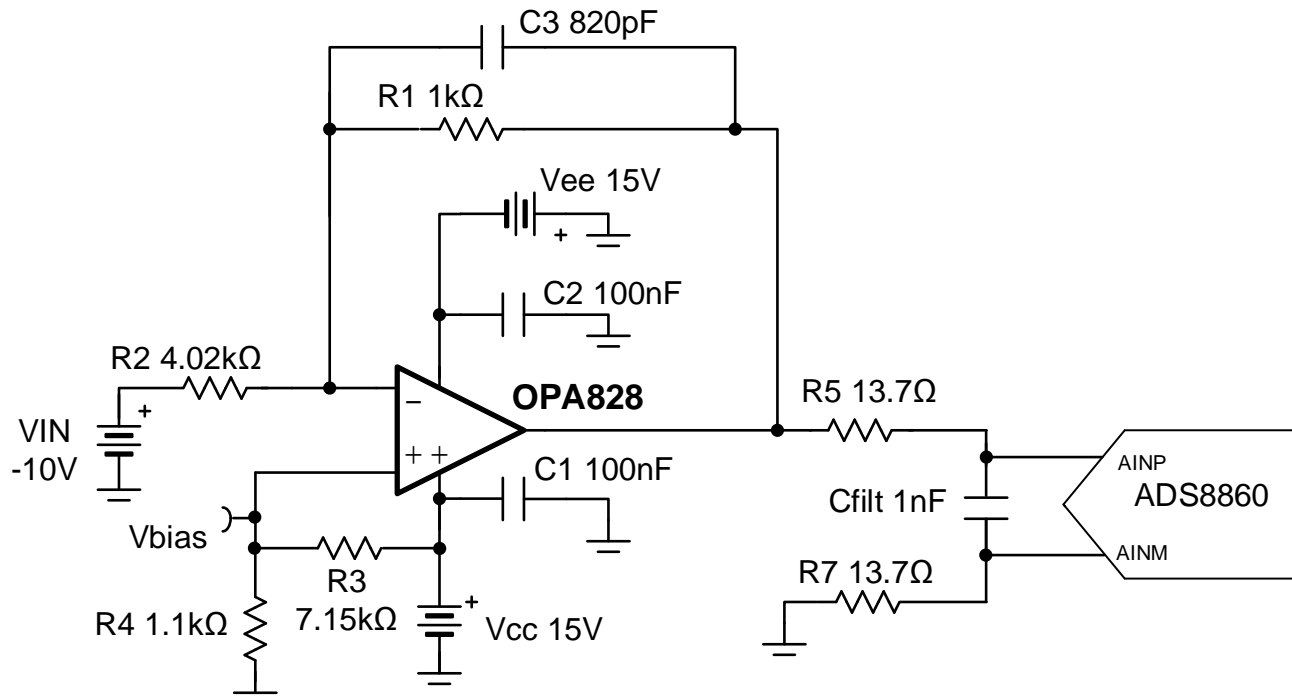

Figure 57. OPA828 Configured as a SAR Driver

#### 8.2.1.1 Design Requirements

The design requirements for this example include:

- Power the OPA828 from  $\pm 15$ -V power supplies
- Amplifier output must settle to 16-bit accuracy in less than 290 ns
- Gain =  $-1/4$
- Amplifier output is biased to 2V
- Amplifier input =  $\pm 10$  V, Output = 0 V to 5 V

## Typical Applications (continued)

### 8.2.1.2 Detailed Design Procedure

The OPA828 is configured as shown in to enable a wide input voltage range of  $\pm 10$  V to be attenuated to 0 V to 5 V. The output range of the amplifier is selected based on the full scale input range of the ADS8860, a 16-bit, 1 MSPS SAR ADC. Supply rails of  $\pm 15$  V are used so the amplifier can achieve linear swing across the full input range. This design allows the amplifier output to settle to 16-bits within the 290-ns acquisition time of the selected ADC.

The [Analog Engineer's Calculator](#) is used to select the resistors and capacitors used to set the signal attenuation as well as the charge bucket between the amplifier and ADC. The input and feedback resistors are chosen to provide a gain of  $-1/4$  (for example, a  $4\times$  attenuation in an inverting configuration).  $V_{BIAS}$  is fixed at 2 V to enable the output to swing from 0 V to 5 V. shows the simulated settling time of this circuit. To function properly the output of the amplifier must settle to within  $\pm 1/2$  LSB before the end of the ADC's acquisition cycle. In this example using the OPA8860, the output of the amplifier must settle to within  $\pm 38.15$   $\mu$ V.  $V_{error}$  is the difference between the expected output and the actual output of the amplifier.

An 820 pF capacitor is added to the feedback to create a lowpass filter with a cutoff frequency of 194 kHz. This filter reduces the noise seen by the ADC and improves the accuracy of the system. The DC transfer function of this circuit is shown in [Figure 59](#) and the AC response in shown in [Figure 60](#).

See [TI Precision Labs](#) for more details and training on configuring an amplifier for ADC drive, selecting the resistors and capacitor for the charge bucket and other signal chain topics.

### 8.2.1.3 Application Curves

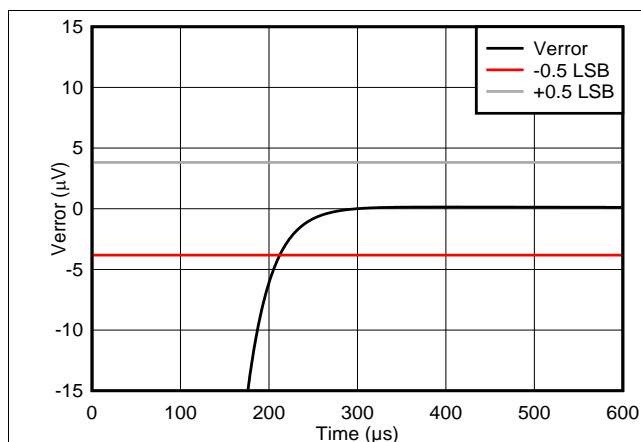

Figure 58. OPA828 Output Settling Time

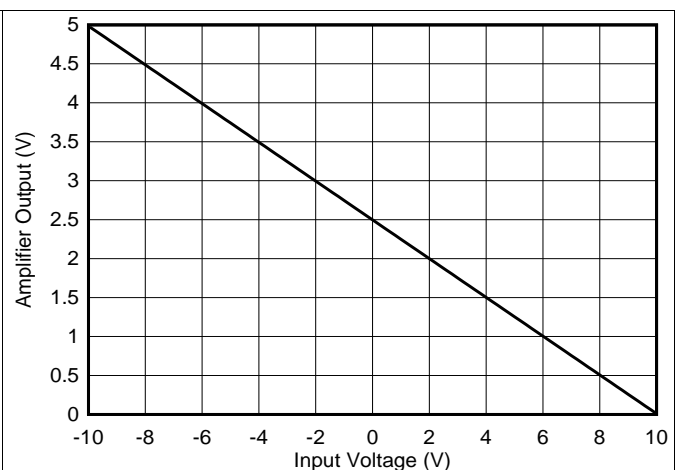
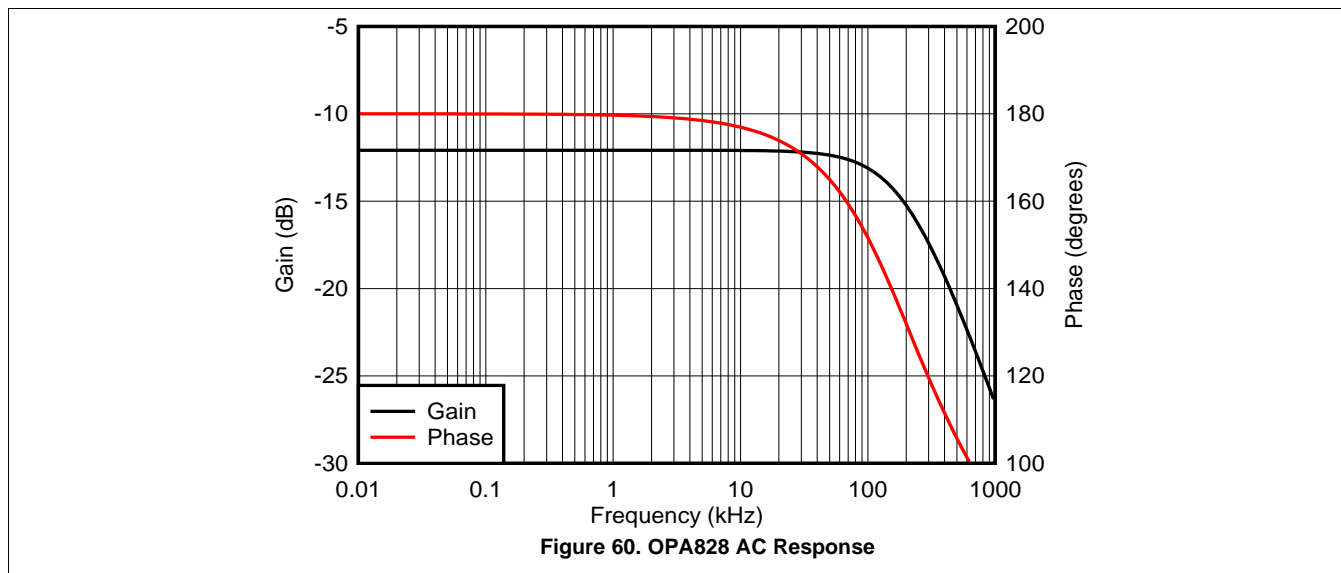
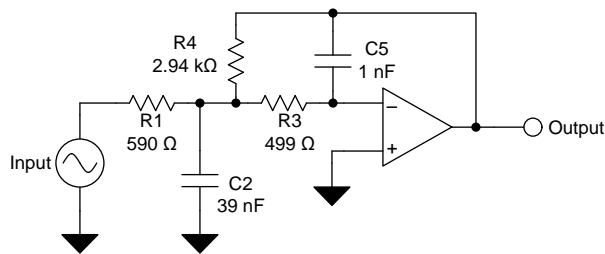

Figure 59. OPA828 DC Transfer Function

Typical Applications (continued)



8.2.2 Typical Application: Low-Pass Filter



Copyright © 2016, Texas Instruments Incorporated

Figure 61. Typical OPA828 Application Schematic

8.2.2.1 Design Requirements

Use the following parameters for this design example:

- Gain = 5 V/V (inverting gain)
- Low-pass cutoff frequency = 25 kHz
- Second-order Chebyshev filter response with 3-dB gain peaking in the passband

8.2.2.2 Detailed Design Procedure

The infinite-gain multiple-feedback circuit for a low-pass network function is shown in Figure 61. Use Equation 6 to calculate the voltage transfer function.

$$\frac{\text{Output}}{\text{Input}}(s) = \frac{-1/R_1R_3C_2C_5}{s^2 + (s/C_2)(1/R_1 + 1/R_3 + 1/R_4) + 1/R_3R_4C_2C_5} \tag{6}$$

This circuit produces a signal inversion. For this circuit, the gain at dc and the low-pass cutoff frequency are calculated by Equation 7:

$$\text{Gain} = \frac{R_4}{R_1}$$

$$f_c = \frac{1}{2\pi} \sqrt{(1/R_3R_4C_2C_5)} \tag{7}$$

## Typical Applications (continued)

Software tools are readily available to simplify filter design. [WEBENCH® Filter Designer](#) is a simple, powerful, and easy-to-use active filter design program. The WEBENCH Filter Designer lets designers create optimized filter designs using a selection of TI operational amplifiers and passive components from TI's vendor partners.

Available as a web-based tool from the WEBENCH® Design Center, [WEBENCH® Filter Designer](#) allows to design, optimize, and simulate complete multi-stage active filter solutions within minutes.

### 8.2.2.3 Application Curve

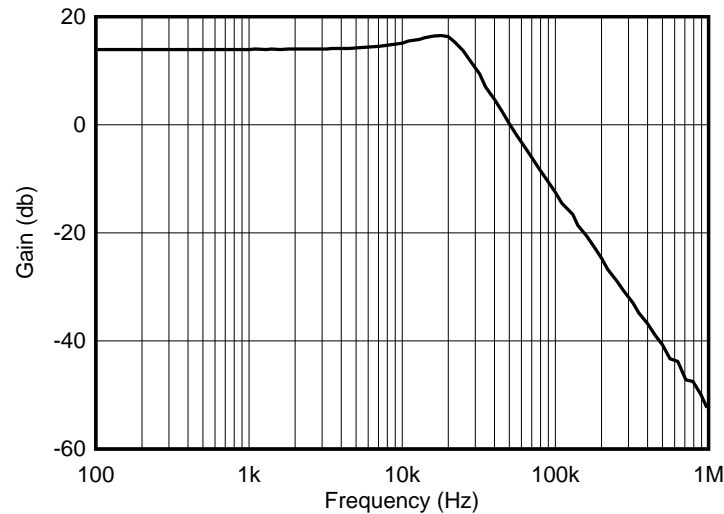

**Figure 62. Low-Pass Filter Transfer Function**

## 9 Power Supply Recommendations

The OPA828 is specified to operate from 8 V to 36 V ( $\pm 4$  V to  $\pm 18$  V); many specifications apply from  $-40^{\circ}\text{C}$  to  $+125^{\circ}\text{C}$ . Parameters that can exhibit significant variance with regard to operating voltage or temperature are presented in the typical curves.

Place 0.1- $\mu\text{F}$  bypass capacitors close to the power-supply pins to reduce errors coupling in from noisy or highimpedance power supplies. For more detailed information on bypass capacitor placement, refer to the [Layout](#) section.

## 10 Layout

### 10.1 Layout Guidelines

For best operational performance of the device, use good printed circuit board (PCB) layout practices, including the following guidelines:

- Noise can propagate into analog circuitry through the power pins of the circuit as a whole and op amp itself. Use bypass capacitors to reduce the coupled noise by providing low-impedance power sources local to the analog circuitry.
- Connect low-ESR, 0.1- $\mu$ F ceramic bypass capacitors between each supply pin and ground, placed as close as possible to the device. A single bypass capacitor from V+ to ground is applicable for single-supply applications.
- Separate grounding for analog and digital portions of circuitry is one of the simplest and most-effective methods of noise suppression. One or more layers on multilayer PCBs are usually devoted to ground planes. A ground plane helps distribute heat and reduces EMI noise pickup. Make sure to physically separate digital and analog grounds paying attention to the flow of the ground current.
- To reduce parasitic coupling, run the input traces as far away from the supply or output traces as possible. If these traces cannot be kept separate, crossing the sensitive trace perpendicular is much better as opposed to in parallel with the noisy trace.
- Place the external components as close as possible to the device.
- Keep the length of input traces as short as possible. Always remember that the input traces are the most sensitive part of the circuit.
- Consider a driven, low-impedance guard ring around the critical traces. A guard ring can significantly reduce leakage currents from nearby traces that are at different potentials.
- TI recommends cleaning the PCB following board assembly for best performance.
- Any precision integrated circuit may experience performance shifts due to moisture ingress into the plastic package. Following any aqueous PCB cleaning process, baking the PCB assembly is recommended to remove moisture introduced into the device packaging during the cleaning process. A low-temperature, post-cleaning bake at 85°C for 30 minutes is sufficient for most circumstances.



## 10.2 Layout Example

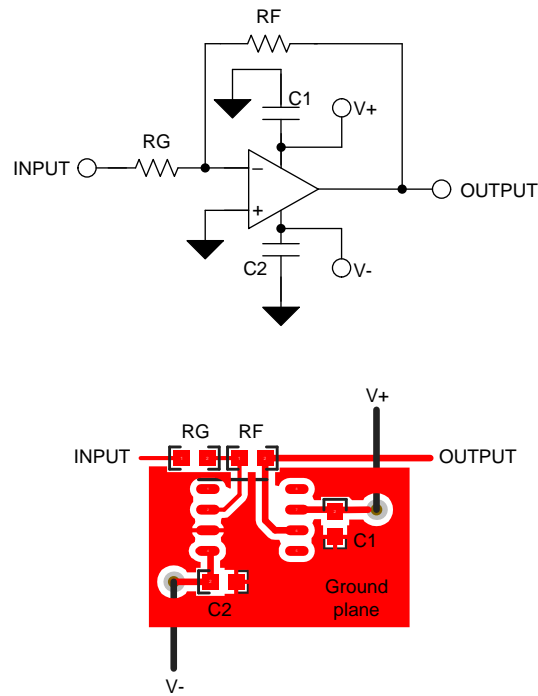

Copyright © 2017, Texas Instruments Incorporated

**Figure 63. OPA828 PCB Example**

## 11 Device and Documentation Support

### 11.1 Device Support

#### 11.1.1 Development Support

For development support see the following:

[WEBENCH® Filter Designer](#)

### 11.2 Documentation Support

#### 11.2.1 Related Documentation

For related documentation see the following:

[Compensate Transimpedance Amplifiers Intuitively](#)

### 11.3 Receiving Notification of Documentation Updates

To receive notification of documentation updates, navigate to the device product folder on ti.com. In the upper right corner, click on *Alert me* to register and receive a weekly digest of any product information that has changed. For change details, review the revision history included in any revised document.

### 11.4 Community Resource

The following links connect to TI community resources. Linked contents are provided "AS IS" by the respective contributors. They do not constitute TI specifications and do not necessarily reflect TI's views; see TI's [Terms of Use](#).

**TI E2E™ Online Community** *TI's Engineer-to-Engineer (E2E) Community*. Created to foster collaboration among engineers. At e2e.ti.com, you can ask questions, share knowledge, explore ideas and help solve problems with fellow engineers.

**Design Support** *TI's Design Support* Quickly find helpful E2E forums along with design support tools and contact information for technical support.

### 11.5 Trademarks

E2E is a trademark of Texas Instruments.

All other trademarks are the property of their respective owners.

### 11.6 Electrostatic Discharge Caution



These devices have limited built-in ESD protection. The leads should be shorted together or the device placed in conductive foam during storage or handling to prevent electrostatic damage to the MOS gates.

### 11.7 Glossary

[SLYZ022](#) — *TI Glossary*.

This glossary lists and explains terms, acronyms, and definitions.

## 12 Mechanical, Packaging, and Orderable Information

The following pages include mechanical, packaging, and orderable information. This information is the most current data available for the designated devices. This data is subject to change without notice and revision of this document. For browser-based versions of this data sheet, refer to the left-hand navigation.

**PACKAGING INFORMATION**

Orderable Device	Status (1)	Package Type	Package Drawing	Pins	Package Qty	Eco Plan (2)	Lead finish/ Ball material (6)	MSL Peak Temp (3)	Op Temp (°C)	Device Marking (4/5)	Samples
OPA828ID	ACTIVE	SOIC	D	8	75	RoHS & Green	NIPDAU	Level-2-260C-1 YEAR	-40 to 125	OPA828	<a href="#">Samples</a>
OPA828IDR	ACTIVE	SOIC	D	8	2500	RoHS & Green	NIPDAU	Level-2-260C-1 YEAR	-40 to 125	OPA828	<a href="#">Samples</a>

(1) The marketing status values are defined as follows:

**ACTIVE:** Product device recommended for new designs.

**LIFEBUY:** TI has announced that the device will be discontinued, and a lifetime-buy period is in effect.

**NRND:** Not recommended for new designs. Device is in production to support existing customers, but TI does not recommend using this part in a new design.

**PREVIEW:** Device has been announced but is not in production. Samples may or may not be available.

**OBSELETE:** TI has discontinued the production of the device.

(2) **RoHS:** TI defines "RoHS" to mean semiconductor products that are compliant with the current EU RoHS requirements for all 10 RoHS substances, including the requirement that RoHS substance do not exceed 0.1% by weight in homogeneous materials. Where designed to be soldered at high temperatures, "RoHS" products are suitable for use in specified lead-free processes. TI may reference these types of products as "Pb-Free".

**RoHS Exempt:** TI defines "RoHS Exempt" to mean products that contain lead but are compliant with EU RoHS pursuant to a specific EU RoHS exemption.

**Green:** TI defines "Green" to mean the content of Chlorine (Cl) and Bromine (Br) based flame retardants meet JS709B low halogen requirements of <=1000ppm threshold. Antimony trioxide based flame retardants must also meet the <=1000ppm threshold requirement.

(3) MSL, Peak Temp. - The Moisture Sensitivity Level rating according to the JEDEC industry standard classifications, and peak solder temperature.

(4) There may be additional marking, which relates to the logo, the lot trace code information, or the environmental category on the device.

(5) Multiple Device Markings will be inside parentheses. Only one Device Marking contained in parentheses and separated by a "~" will appear on a device. If a line is indented then it is a continuation of the previous line and the two combined represent the entire Device Marking for that device.

(6) Lead finish/Ball material - Orderable Devices may have multiple material finish options. Finish options are separated by a vertical ruled line. Lead finish/Ball material values may wrap to two lines if the finish value exceeds the maximum column width.

**Important Information and Disclaimer:**The information provided on this page represents TI's knowledge and belief as of the date that it is provided. TI bases its knowledge and belief on information provided by third parties, and makes no representation or warranty as to the accuracy of such information. Efforts are underway to better integrate information from third parties. TI has taken and continues to take reasonable steps to provide representative and accurate information but may not have conducted destructive testing or chemical analysis on incoming materials and chemicals. TI and TI suppliers consider certain information to be proprietary, and thus CAS numbers and other limited information may not be available for release.

In no event shall TI's liability arising out of such information exceed the total purchase price of the TI part(s) at issue in this document sold by TI to Customer on an annual basis.



**TAPE AND REEL INFORMATION**

**QUADRANT ASSIGNMENTS FOR PIN 1 ORIENTATION IN TAPE**

\*All dimensions are nominal

Device	Package Type	Package Drawing	Pins	SPQ	Reel Diameter (mm)	Reel Width W1 (mm)	A0 (mm)	B0 (mm)	K0 (mm)	P1 (mm)	W (mm)	Pin1 Quadrant
OPA828IDR	SOIC	D	8	2500	330.0	12.4	6.4	5.2	2.1	8.0	12.0	Q1

**TAPE AND REEL BOX DIMENSIONS**

\*All dimensions are nominal

Device	Package Type	Package Drawing	Pins	SPQ	Length (mm)	Width (mm)	Height (mm)
OPA828IDR	SOIC	D	8	2500	853.0	449.0	35.0



D0008A

# PACKAGE OUTLINE

SOIC - 1.75 mm max height

SMALL OUTLINE INTEGRATED CIRCUIT



4214825/C 02/2019

NOTES:

- Linear dimensions are in inches [millimeters]. Dimensions in parenthesis are for reference only. Controlling dimensions are in inches. Dimensioning and tolerancing per ASME Y14.5M.
- This drawing is subject to change without notice.
- This dimension does not include mold flash, protrusions, or gate burrs. Mold flash, protrusions, or gate burrs shall not exceed .006 [0.15] per side.
- This dimension does not include interlead flash.
- Reference JEDEC registration MS-012, variation AA.

# EXAMPLE BOARD LAYOUT

D0008A

SOIC - 1.75 mm max height

SMALL OUTLINE INTEGRATED CIRCUIT



LAND PATTERN EXAMPLE  
 EXPOSED METAL SHOWN  
 SCALE:8X



SOLDER MASK DETAILS

4214825/C 02/2019

NOTES: (continued)

- 6. Publication IPC-7351 may have alternate designs.
- 7. Solder mask tolerances between and around signal pads can vary based on board fabrication site.



# EXAMPLE STENCIL DESIGN

D0008A

SOIC - 1.75 mm max height

SMALL OUTLINE INTEGRATED CIRCUIT



SOLDER PASTE EXAMPLE  
BASED ON .005 INCH [0.125 MM] THICK STENCIL  
SCALE:8X

4214825/C 02/2019

NOTES: (continued)

8. Laser cutting apertures with trapezoidal walls and rounded corners may offer better paste release. IPC-7525 may have alternate design recommendations.
9. Board assembly site may have different recommendations for stencil design.

## IMPORTANT NOTICE AND DISCLAIMER

TI PROVIDES TECHNICAL AND RELIABILITY DATA (INCLUDING DATASHEETS), DESIGN RESOURCES (INCLUDING REFERENCE DESIGNS), APPLICATION OR OTHER DESIGN ADVICE, WEB TOOLS, SAFETY INFORMATION, AND OTHER RESOURCES "AS IS" AND WITH ALL FAULTS, AND DISCLAIMS ALL WARRANTIES, EXPRESS AND IMPLIED, INCLUDING WITHOUT LIMITATION ANY IMPLIED WARRANTIES OF MERCHANTABILITY, FITNESS FOR A PARTICULAR PURPOSE OR NON-INFRINGEMENT OF THIRD PARTY INTELLECTUAL PROPERTY RIGHTS.

These resources are intended for skilled developers designing with TI products. You are solely responsible for (1) selecting the appropriate TI products for your application, (2) designing, validating and testing your application, and (3) ensuring your application meets applicable standards, and any other safety, security, or other requirements. These resources are subject to change without notice. TI grants you permission to use these resources only for development of an application that uses the TI products described in the resource. Other reproduction and display of these resources is prohibited. No license is granted to any other TI intellectual property right or to any third party intellectual property right. TI disclaims responsibility for, and you will fully indemnify TI and its representatives against, any claims, damages, costs, losses, and liabilities arising out of your use of these resources.

TI's products are provided subject to TI's Terms of Sale (<https://www.ti.com/legal/termsofsale.html>) or other applicable terms available either on [ti.com](https://www.ti.com) or provided in conjunction with such TI products. TI's provision of these resources does not expand or otherwise alter TI's applicable warranties or warranty disclaimers for TI products.

Mailing Address: Texas Instruments, Post Office Box 655303, Dallas, Texas 75265  
Copyright © 2021, Texas Instruments Incorporated