

Front view and mounting

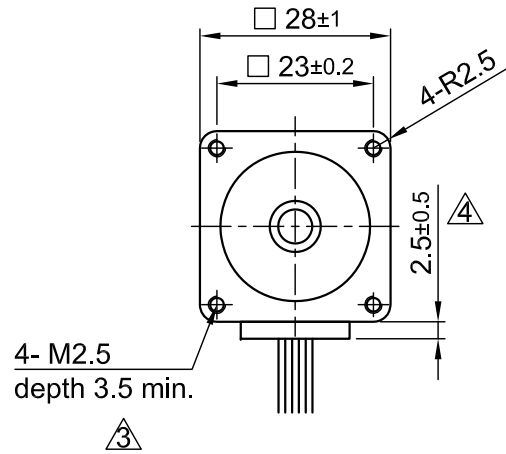

Side view

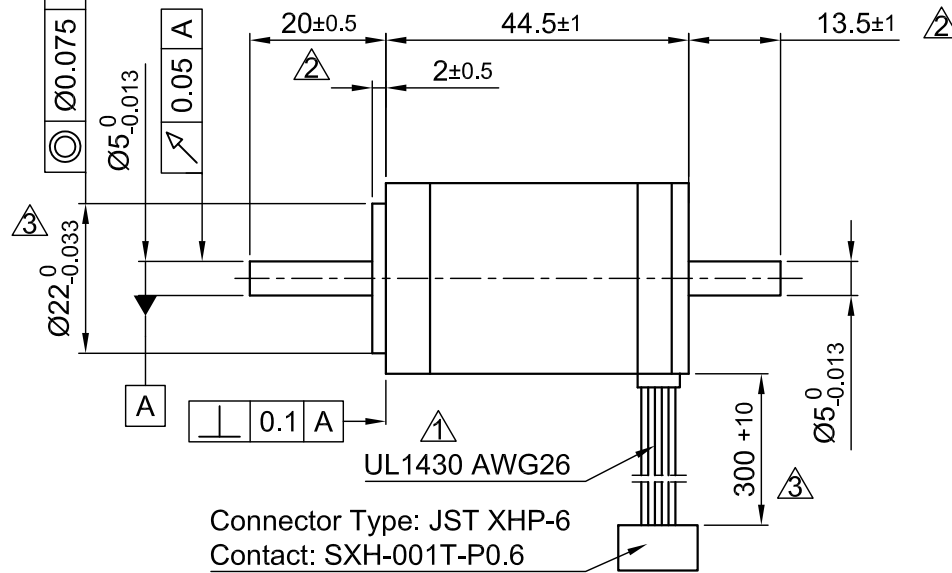

Rear view

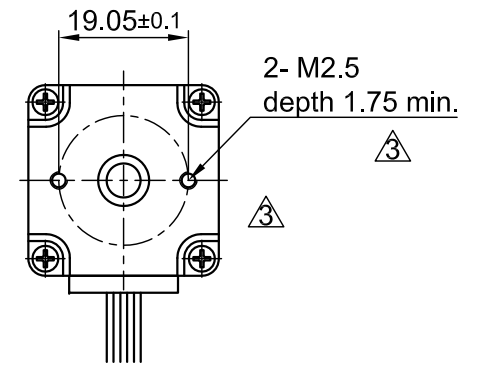

SPECIFICATION	UNIPOLAR OR BIPOLAR-1 WINDING	BIPOLAR SERIES
VOLTAGE (VDC)	3.23	4.56
AMPS/PHASE	0.95	0.67
RESISTANCE/PHASE (Ohms)@25°C	3.4±15%	6.8±15%
INDUCTANCE/PHASE (mH) @1KHz	1.2±20%	4.8±20%
HOLDING TORQUE (Nm) [lb-in]	0.075 [0.664]	0.106 [0.938]
DETENT TORQUE (Nm) [lb-in]	3.75x10 ⁻³ [3.3x10 ⁻²]	
STEP ANGLE (°)	1.8	
STEP ACCURACY (NON-ACCUM)	±5%	
ROTOR INERTIA (Kg-m ²) [lb-in ²]	1.2x10 ⁻⁶ [4.1x10 ⁻³]	
WEIGHT (Kg) [lb]	0.176 [0.388]	

PERMISSIBLE RADIAL+AXIAL FORCE

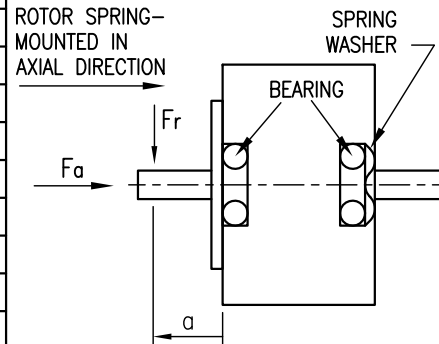

TEMPERATURE RISE: MAX.80°C (MOTOR STANDSTILL; FOR 2 PHASE ENERGIZED)	AXIAL-FORCE Fa (N)	Fa=7			
AMBIENT TEMPERATURE -10~ 50°C [14°F ~ 122°F]	DISTANCE a (mm)	5	10	15	20
INSULATION RESISTANCE 100 MOhm (UNDER NORMAL TEMPERATURE AND HUMIDITY)	RADIAL-FORCE Fr (N)	58	36	26	20
INSULATION CLASS B 130° [266°F]		AXIAL		RADIAL	
DIELECTRIC STRENGTH 500VAC FOR 1 MIN. (BETWEEN THE MOTOR COILS AND THE MOTOR CASE)	SHAFT PLAY (mm)	0.075		0.025	
AMBIENT HUMIDITY MAX. 85% (NO CONDENSATION)	AT LOAD MAX: (N)	10		5.0	

TYPE OF CONNECTION (EXTERN)			MOTOR		
UNIPOLAR	BIPOLAR		CONNECTOR PIN NO.	LEADS	WINDING
	1WINDING	SERIES			
A ---	A ---	A ---	1	BLK	A
COM ---	COM ---	---	5	YEL	COM
A\ ---	---	A\ ---	3	GRN	A\
B ---	B ---	B ---	2	RED	B
COM ---	COM ---	---	6	WHT	COM
B\ ---	---	B\ ---	4	BLU	B\

for >speed ←
for <speed →

FULL STEP 2 PHASE-Ex.,
WHEN FACING MOUNTING END (X)

STEP	A	B	A\	B\	CCW	CW
1	+	+	-	-	↓	↑
2	-	+	+	-	↑	↓
3	-	-	+	+	↓	↑
4	+	-	-	+	↑	↓

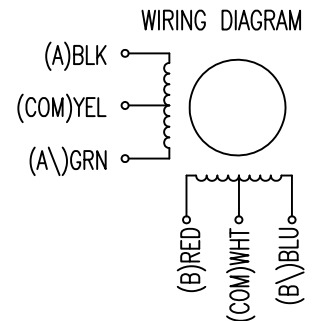

4	change tolerance/ revise drawing	11.01.17	A.S.
3	CHANGE TOL. M2.5/Ø22/ rework draw	17.12.15	A.S.
2	CHANGE TOLERANCE	21.02.14	J.D.
REV	DESCRIPTION	DATE	DRN



Surface specification DIN ISO 1302	General tolerances DIN ISO 2768- cH	Work piece edge DIN ISO 13715
---------------------------------------	--	----------------------------------

APVD	S.K.	06.06.06
CHKD		
DRN	J.W.	06.06.06
SIGNATURE	DATE	

STEPPING MOTOR

DWG.NO

ST2818M1006-B