



# STP11NM80 - STF11NM80 STB11NM80 - STW11NM80

N-CHANNEL 800V - 0.35  $\Omega$  - 11 A TO-220 /FP/D<sup>2</sup>PAK/TO-247  
MDmesh™ MOSFET

**Table 1: General Features**

TYPE	V <sub>DSS</sub>	R <sub>DS(on)</sub>	R <sub>DS(on)</sub> *Q <sub>g</sub>	I <sub>D</sub>
STP11NM80	800 V	< 0.40 $\Omega$	14 $\Omega$ *nC	11 A
STF11NM80	800 V	< 0.40 $\Omega$	14 $\Omega$ *nC	11 A
STB11NM80	800 V	< 0.40 $\Omega$	14 $\Omega$ *nC	11 A
STW11NM80	800 V	< 0.40 $\Omega$	14 $\Omega$ *nC	11 A

- TYPICAL R<sub>DS(on)</sub> = 0.35  $\Omega$
- LOW GATE INPUT RESISTANCE
- LOW INPUT CAPACITANCE AND GATE CHARGE
- BEST R<sub>DS(on)</sub>\*Q<sub>g</sub> IN THE INDUSTRY

## DESCRIPTION

The MDmesh™ associates the Multiple Drain process with the Company's PowerMesh™ horizontal layout assuring an outstanding low on-resistance. The adoption of the Company's proprietary strip technique yields overall dynamic performance that is significantly better than that of similar competitor's products.

## APPLICATIONS

The 800 V MDmesh™ family is very suitable for single switch applications in particular for Flyback and Forward converter topologies and for ignition circuits in the field of lighting.

**Table 2: Order Codes**

SALES TYPE	MARKING	PACKAGE	PACKAGING
STP11NM80	P11NM80	TO-220	TUBE
STF11NM80	F11NM80	TO-220FP	TUBE
STB11NM80T4	B11NM80	D <sup>2</sup> PAK	TAPE & REEL
STW11NM80	W11NM80	TO-247	TUBE

**Figure 1: Package**

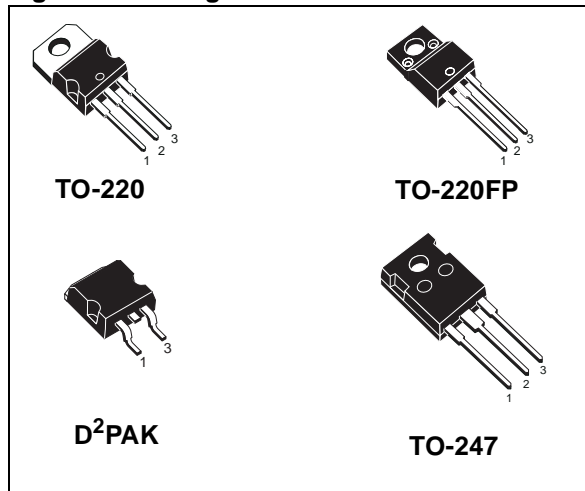

**Figure 2: Internal Schematic Diagram**

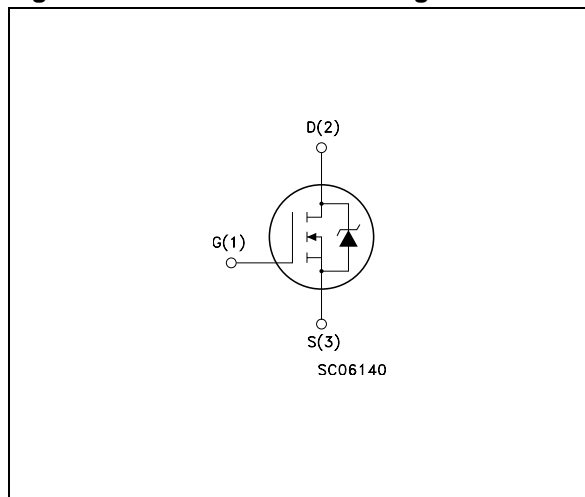

**Table 3: Absolute Maximum ratings**

Symbol	Parameter	Value		Unit
		TO-220/D <sup>2</sup> PAK TO-247	TO-220FP	
V <sub>DS</sub>	Drain-source Voltage (V <sub>GS</sub> = 0)	800		V
V <sub>DGR</sub>	Drain-gate Voltage (R <sub>GS</sub> = 20 kΩ)	800		V
V <sub>GS</sub>	Gate- source Voltage	± 30		V
I <sub>D</sub>	Drain Current (continuous) at T <sub>C</sub> = 25°C	11	11 (*)	A
I <sub>D</sub>	Drain Current (continuous) at T <sub>C</sub> = 100°C	4.7	4.7 (*)	A
I <sub>DM</sub> (•)	Drain Current (pulsed)	44	44 (*)	A
P <sub>TOT</sub>	Total Dissipation at T <sub>C</sub> = 25°C	150	35	W
	Derating Factor	1.2	0.28	W / °C
T <sub>j</sub> T <sub>stg</sub>	Operating Junction Temperature Storage Temperature	-65 to 150		°C

(•) Pulse width limited by safe operating area

(\*) Limited only by the Maximum Temperature Allowed

**Table 4: Thermal Data**

		TO-220/D <sup>2</sup> PAK TO-247	TO-220FP	Unit
R <sub>thj-case</sub>	Thermal Resistance Junction-case Max	0.83	3.6	°C/W
R <sub>thj-amb</sub>	Thermal Resistance Junction-ambient Max	62.5		°C/W
T <sub>l</sub>	Maximum Lead Temperature For Soldering Purpose	300		°C

**Table 5: Avalanche Characteristics**

Symbol	Parameter	Max Value	Unit
I <sub>AR</sub>	Avalanche Current, Repetitive or Not-Repetitive (pulse width limited by T <sub>j</sub> max)	2.5	A
E <sub>AS</sub>	Single Pulse Avalanche Energy (starting T <sub>j</sub> = 25 °C, I <sub>D</sub> = 2.5A, V <sub>DD</sub> = 50 V)	400	mJ

**ELECTRICAL CHARACTERISTICS** ( $T_{CASE} = 25^{\circ}C$  UNLESS OTHERWISE SPECIFIED)**Table 6: On/Off**

Symbol	Parameter	Test Conditions	Min.	Typ.	Max.	Unit
$V_{(BR)DSS}$	Drain-source Breakdown Voltage	$I_D = 250 \mu A, V_{GS} = 0$	800			V
$I_{DSS}$	Zero Gate Voltage Drain Current ( $V_{GS} = 0$ )	$V_{DS} = \text{Max Rating}$ $V_{DS} = \text{Max Rating}, T_C = 125^{\circ}C$			10 100	$\mu A$ $\mu A$
$I_{GSS}$	Gate-body Leakage Current ( $V_{DS} = 0$ )	$V_{GS} = \pm 30V$			100	nA
$V_{GS(th)}$	Gate Threshold Voltage	$V_{DS} = V_{GS}, I_D = 250 \mu A$	3	4	5	V
$R_{DS(on)}$	Static Drain-source On Resistance	$V_{GS} = 10V, I_D = 5.5 A$		0.35	0.40	$\Omega$

**Table 7: Dynamic**

Symbol	Parameter	Test Conditions	Min.	Typ.	Max.	Unit
$g_{fs} (1)$	Forward Transconductance	$V_{DS} > I_{D(on)} \times R_{DS(on)max},$ $I_D = 7.5 A$		8		S
$C_{iss}$ $C_{oss}$ $C_{rss}$	Input Capacitance Output Capacitance Reverse Transfer Capacitance	$V_{DS} = 25 V, f = 1 \text{ MHz}, V_{GS} = 0$		1630 750 30		pF pF pF
$R_G$	Gate Input Resistance	f=1 MHz Gate DC Bias = 0 Test Signal Level = 20mV Open Drain		2.7		$\Omega$
$t_{d(on)}$ $t_r$ $t_{d(off)}$ $t_f$	Turn-on Delay Time Rise Time Turn-off Delay Time Fall Time	$V_{DD} = 400 V, I_D = 5.5 A$ $R_G = 4.7\Omega, V_{GS} = 10 V$ (Resistive Load see, Figure 4)		22 17 46 15		ns ns ns ns
$Q_g$ $Q_{gs}$ $Q_{gd}$	Total Gate Charge Gate-Source Charge Gate-Drain Charge	$V_{DD} = 640 V, I_D = 11 A,$ $V_{GS} = 10V$		43.6 11.6 21		nC nC nC

**Table 8: Source Drain Diode**

Symbol	Parameter	Test Conditions	Min.	Typ.	Max.	Unit
$I_{SD}$ $I_{SDM} (2)$	Source-drain Current Source-drain Current (pulsed)				11 44	A A
$V_{SD} (1)$	Forward On Voltage	$I_{SD} = 11 A, V_{GS} = 0$			0.86	V
$t_{rr}$ $Q_{rr}$ $I_{RRM}$	Reverse Recovery Time Reverse Recovery Charge Reverse Recovery Current	$I_{SD} = 11 A, di/dt = 100 A/\mu s$ $V_{DD} = 50 V, T_j = 25^{\circ}C$ (see test circuit, Figure 5)		612 7.22 23.6		ns $\mu C$ A
$t_{rr}$ $Q_{rr}$ $I_{RRM}$	Reverse Recovery Time Reverse Recovery Charge Reverse Recovery Current	$I_{SD} = 11 A, di/dt = 100 A/\mu s$ $V_{DD} = 50 V, T_j = 150^{\circ}C$ (see test circuit, Figure 5)		970 11.25 23.2		ns $\mu C$ A

Note: 1. Pulsed: Pulse duration = 300  $\mu s$ , duty cycle 1.5 %.  
2. Pulse width limited by safe operating area.

Figure 3: Safe Operating Area For D<sup>2</sup>PAK/ TO-247 / TO-220

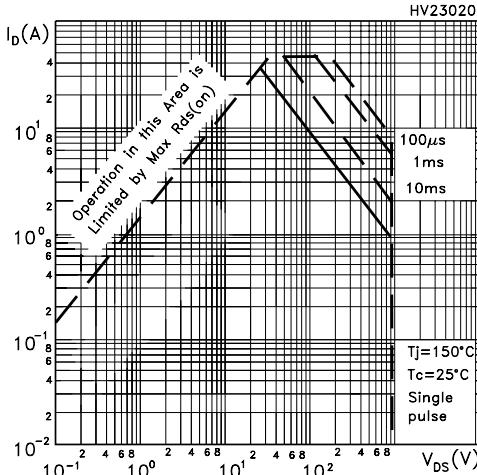

Figure 4: Thermal Impedance For D<sup>2</sup>PAK/ TO-247 / TO-220

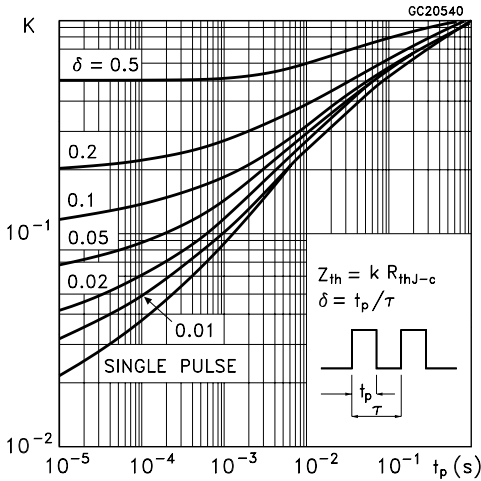

Figure 5: Output Characteristics

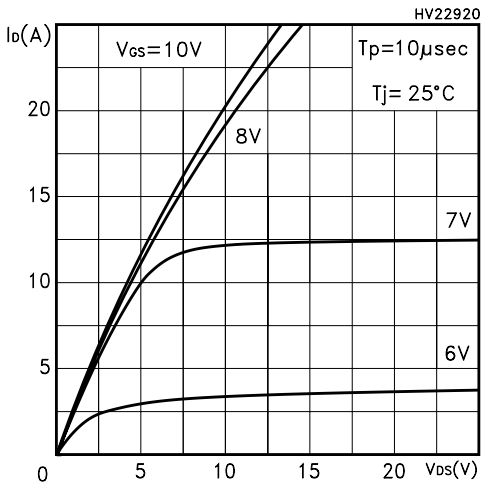

Figure 6: Safe Operating Area For TO-220FP

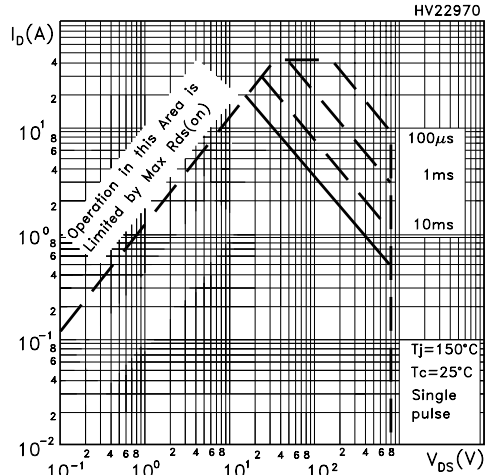

Figure 7: Thermal Impedance For TO-220FP

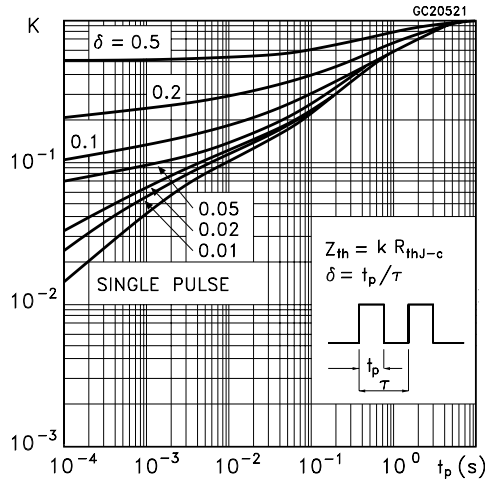

Figure 8: Output Characteristics

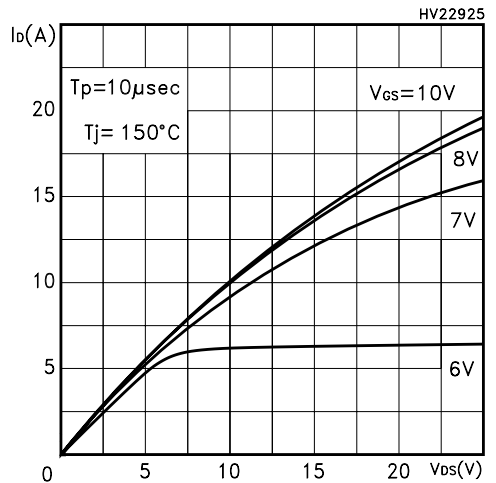

Figure 9: Transfer Characteristics

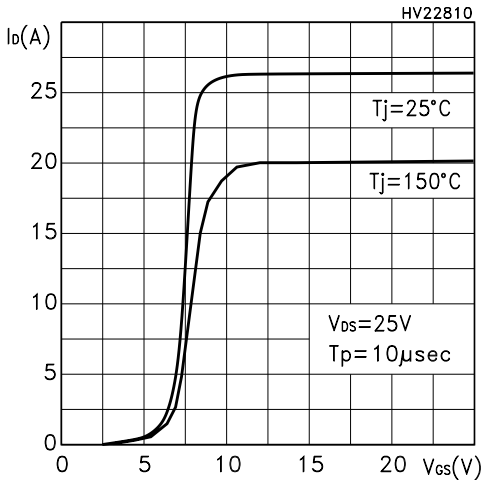

Figure 10: Transconductance

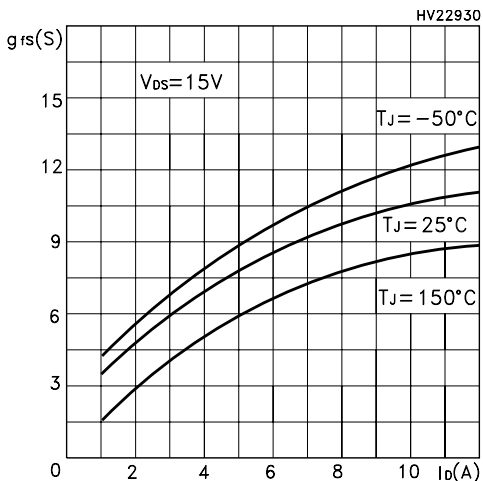

Figure 11: Gate Charge vs Gate-source Voltage

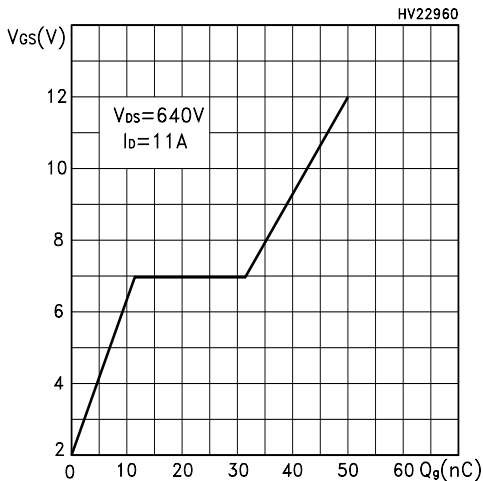

Figure 12: Normalized Gate Threshold Voltage vs Temperature

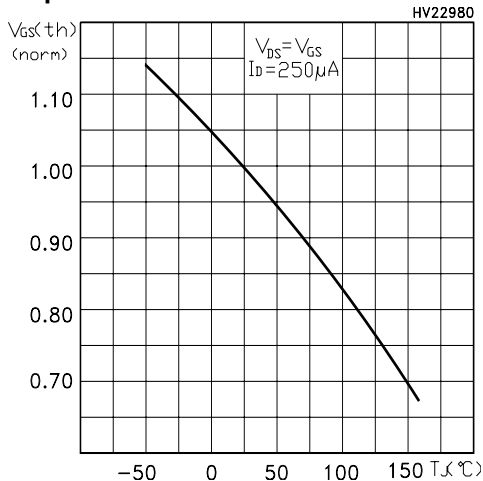

Figure 13: Static Drain-Source On Resistance

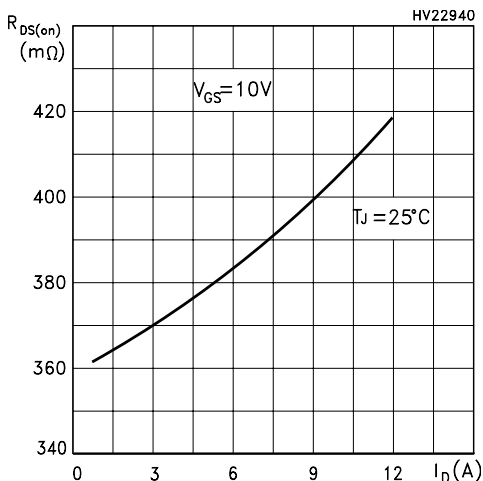

Figure 14: Capacitance Variations

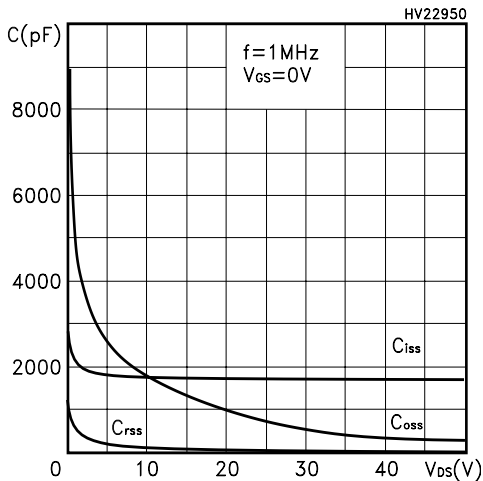

Figure 15: Normalized On Resistance vs Temperature

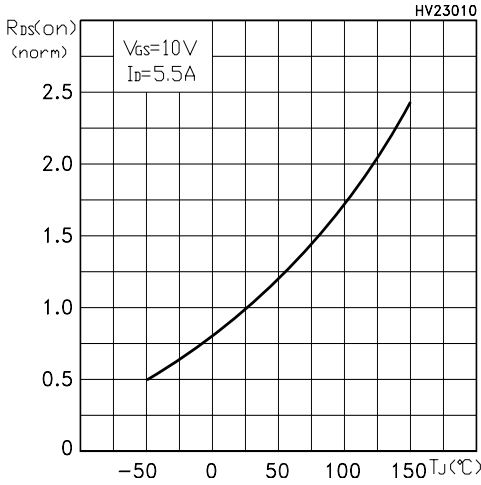

Figure 17: Normalized  $BV_{DSS}$  vs Temperature

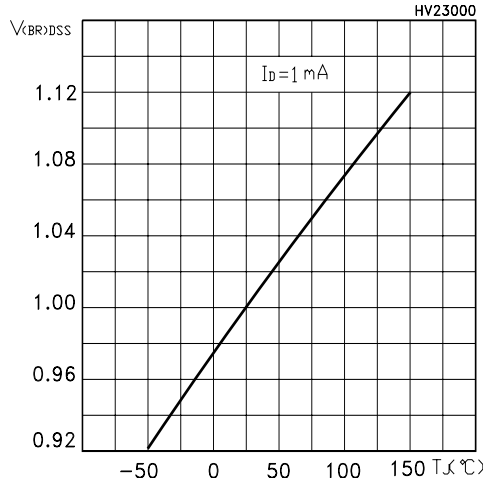

Figure 16: Source-Drain Forward Characteristics

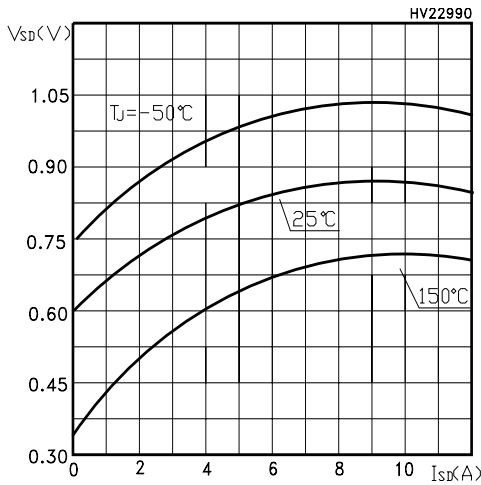

Figure 18: Unclamped Inductive Load Test Circuit

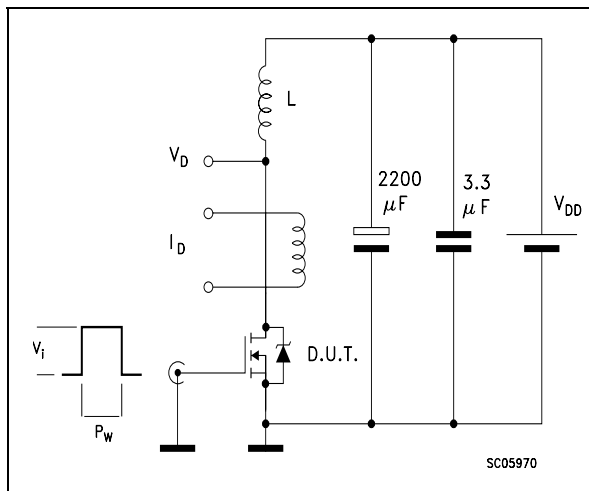

Figure 19: Switching Times Test Circuit For Resistive Load

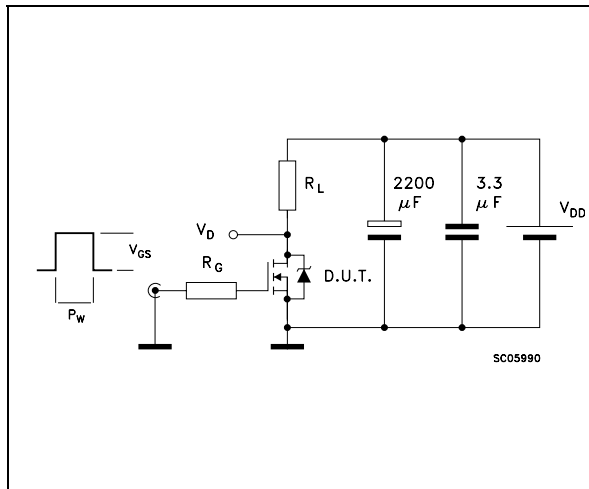

Figure 20: Test Circuit For Inductive Load Switching and Diode Recovery Times

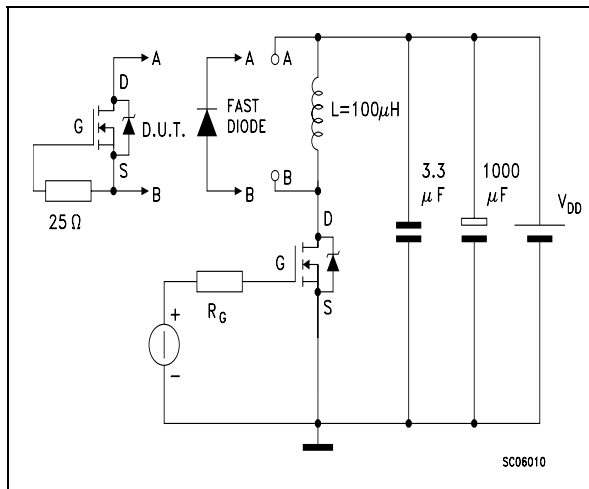

Figure 21: Unclamped Inductive Waferform

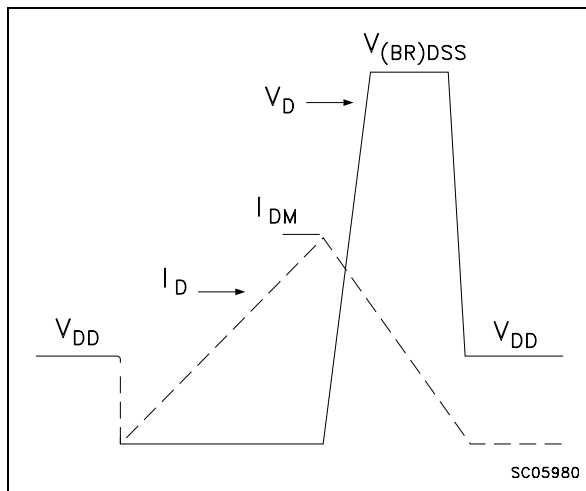
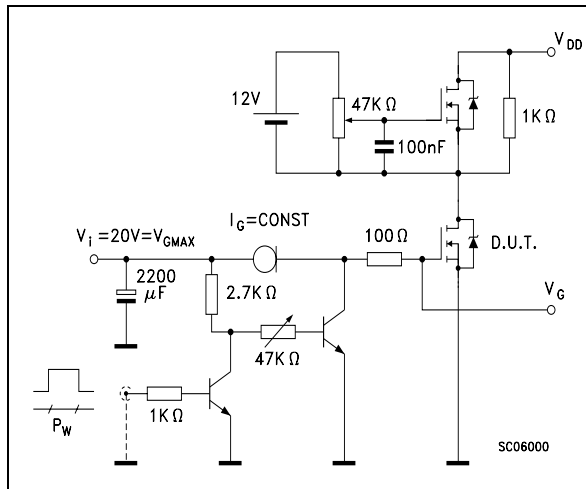
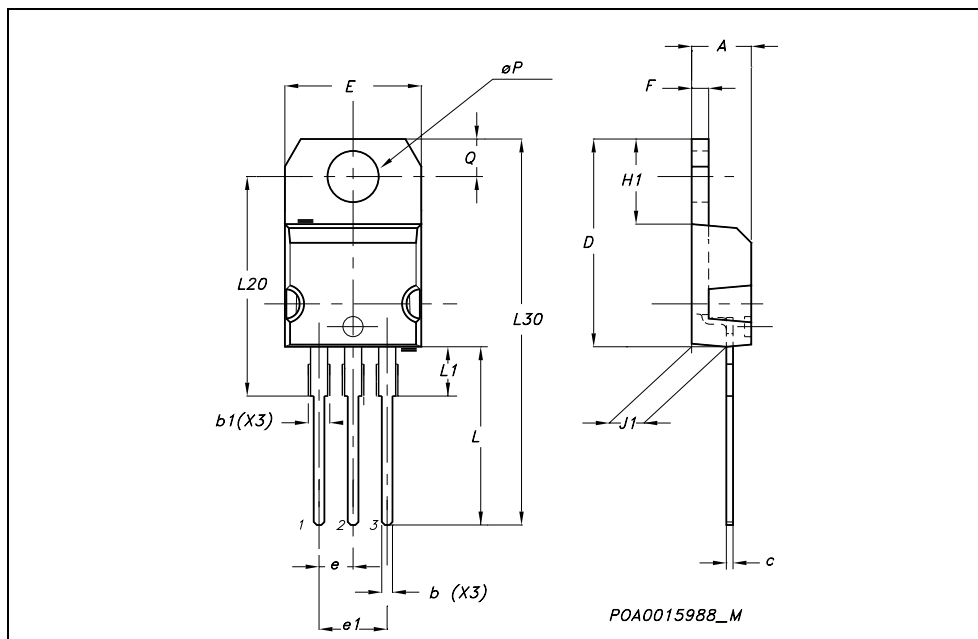

Figure 22: Gate Charge Test Circuit



**TO-220 MECHANICAL DATA**

DIM.	mm.			inch		
	MIN.	TYP.	MAX.	MIN.	TYP.	MAX.
A	4.40		4.60	0.173		0.181
b	0.61		0.88	0.024		0.034
b1	1.15		1.70	0.045		0.066
c	0.49		0.70	0.019		0.027
D	15.25		15.75	0.60		0.620
E	10		10.40	0.393		0.409
e	2.40		2.70	0.094		0.106
e1	4.95		5.15	0.194		0.202
F	1.23		1.32	0.048		0.052
H1	6.20		6.60	0.244		0.256
J1	2.40		2.72	0.094		0.107
L	13		14	0.511		0.551
L1	3.50		3.93	0.137		0.154
L20		16.40			0.645	
L30		28.90			1.137	
øP	3.75		3.85	0.147		0.151
Q	2.65		2.95	0.104		0.116





TO-220FP MECHANICAL DATA

DIM.	mm.			inch		
	MIN.	TYP.	MAX.	MIN.	TYP.	MAX.
A	4.4		4.6	0.173		0.181
B	2.5		2.7	0.098		0.106
D	2.5		2.75	0.098		0.108
E	0.45		0.7	0.017		0.027
F	0.75		1	0.030		0.039
F1	1.15		1.7	0.045		0.067
F2	1.15		1.7	0.045		0.067
G	4.95		5.2	0.195		0.204
G1	2.4		2.7	0.094		0.106
H	10		10.4	0.393		0.409
L2		16			0.630	
L3	28.6		30.6	1.126		1.204
L4	9.8		10.6	.0385		0.417
L5	2.9		3.6	0.114		0.141
L6	15.9		16.4	0.626		0.645
L7	9		9.3	0.354		0.366
Ø	3		3.2	0.118		0.126

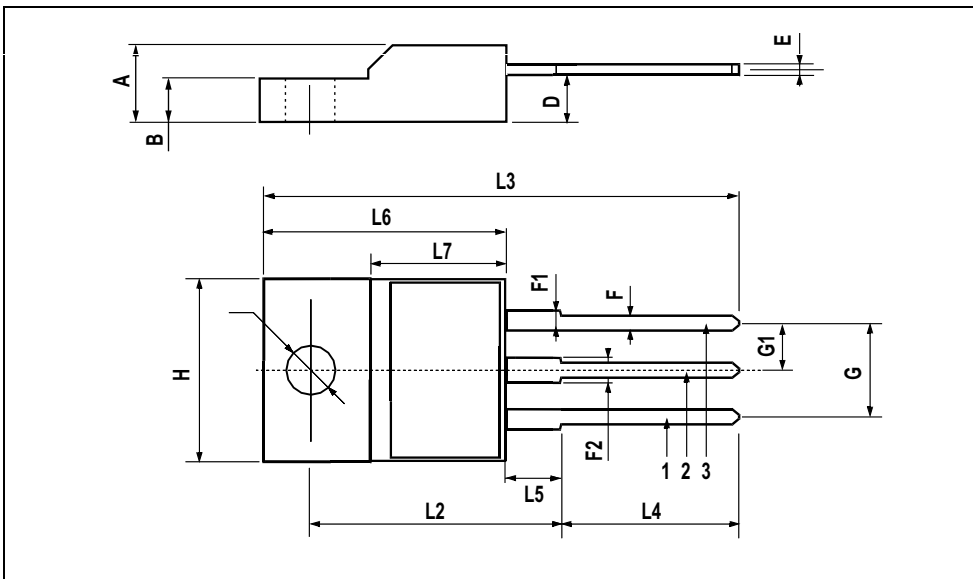

TO-263 (D<sup>2</sup>PAK) MECHANICAL DATA

DIM.	mm.			inch		
	MIN.	TYP.	MAX.	MIN.	TYP.	MAX.
A	4.32		4.57	0.178		0.180
A1	0.00		0.25	0.00		0.009
b	0.71		0.91	0.028		0.350
b2	1.15		1.40	0.045		0.055
c	0.46		0.61	0.018		0.024
c2	1.22		1.40	0.048		0.055
D	8.89	9.02	9.40	0.350	0.355	0.370
D1	8.01			0.315		
E	10.04		10.28	0.395		0.404
e		2.54			0.010	
H	13.10		13.70	0.515		0.540
L	1.30		1.70	0.051		0.067
L1	1.15		1.39	0.045		0.054
L2	1.27		1.77	0.050		0.069
L4	2.70		3.10	0.106		0.122
V2	0°		8°	0°		8°

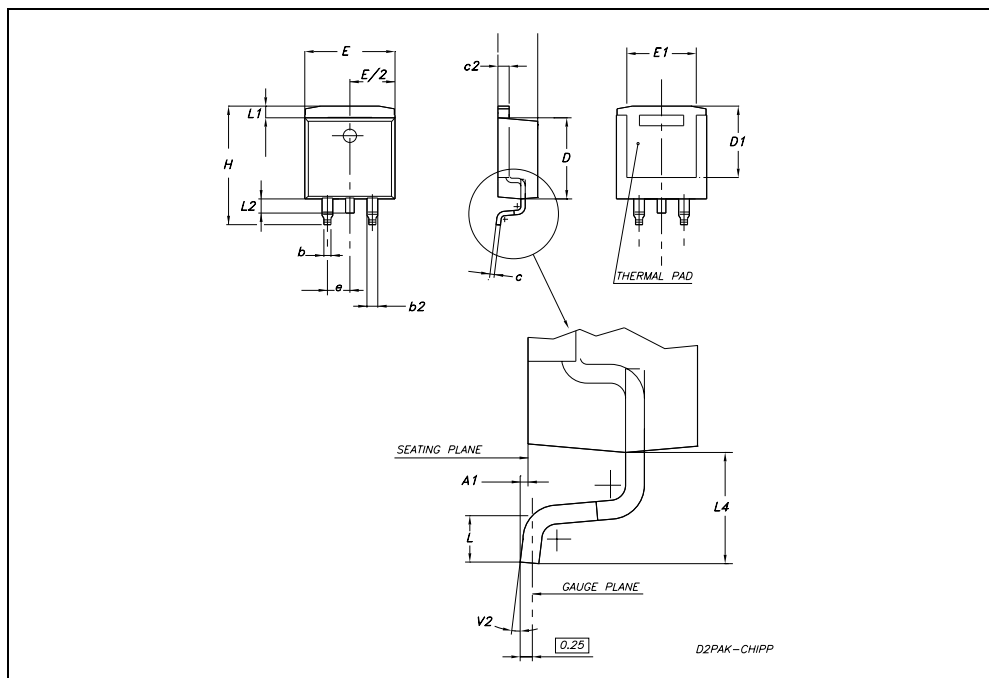

TO-247 MECHANICAL DATA

DIM.	mm.			inch		
	MIN.	TYP.	MAX.	MIN.	TYP.	MAX.
A	4.85		5.15	0.19		0.20
A1	2.20		2.60	0.086		0.102
b	1.0		1.40	0.039		0.055
b1	2.0		2.40	0.079		0.094
b2	3.0		3.40	0.118		0.134
c	0.40		0.80	0.015		0.03
D	19.85		20.15	0.781		0.793
E	15.45		15.75	0.608		0.620
e		5.45			0.214	
L	14.20		14.80	0.560		0.582
L1	3.70		4.30	0.14		0.17
L2		18.50			0.728	
øP	3.55		3.65	0.140		0.143
øR	4.50		5.50	0.177		0.216
S		5.50			0.216	

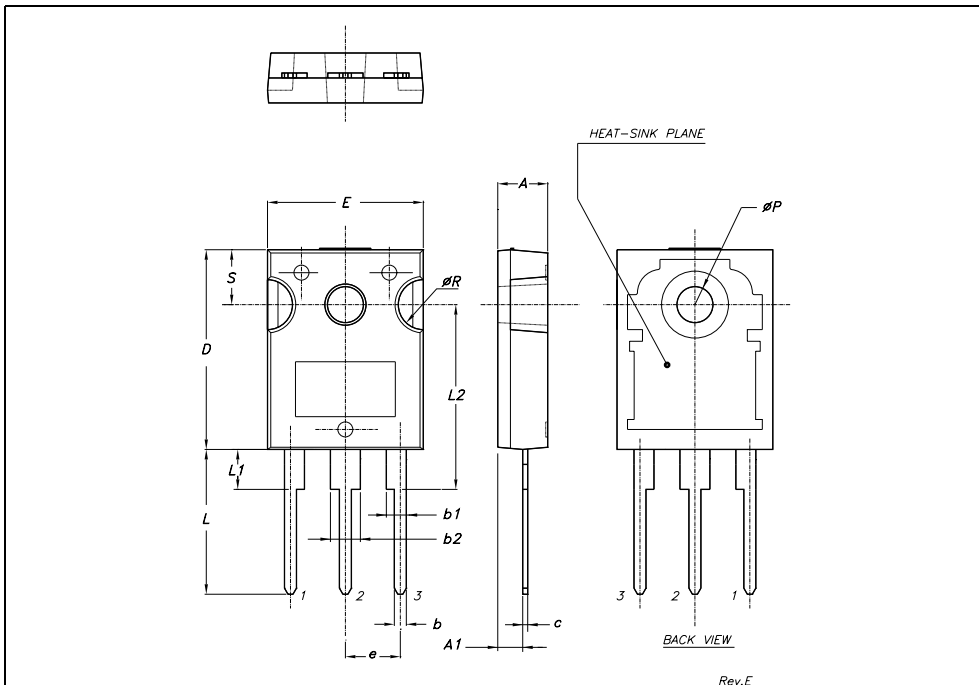

D<sup>2</sup>PAK FOOTPRINT

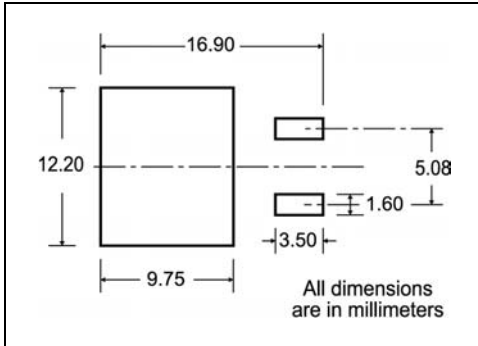

TAPE AND REEL SHIPMENT

**TAPE MECHANICAL DATA**

DIM.	mm		inch	
	MIN.	MAX.	MIN.	MAX.
A0	10.5	10.7	0.413	0.421
B0	15.7	15.9	0.618	0.626
D	1.5	1.6	0.059	0.063
D1	1.59	1.61	0.062	0.063
E	1.65	1.85	0.065	0.073
F	11.4	11.6	0.449	0.456
K0	4.8	5.0	0.189	0.197
P0	3.9	4.1	0.153	0.161
P1	11.9	12.1	0.468	0.476
P2	1.9	2.1	0.075	0.082
R	50		1.574	
T	0.25	0.35	0.0098	0.0137
W	23.7	24.3	0.933	0.956

**REEL MECHANICAL DATA**

DIM.	mm		inch	
	MIN.	MAX.	MIN.	MAX.
A		330		12.992
B	1.5		0.059	
C	12.8	13.2	0.504	0.520
D	20.2		0.795	
G	24.4	26.4	0.960	1.039
N	100		3.937	
T		30.4		1.197

BASE QTY	BULK QTY
1000	1000

\* on sales type

Figure 23: Revision History

Date	Revision	Description of Changes
29-Jul-2004	1	Final Document
20-Oct-2005	2	Modified value on <b>Figure 17</b>

Information furnished is believed to be accurate and reliable. However, STMicroelectronics assumes no responsibility for the consequences of use of such information nor for any infringement of patents or other rights of third parties which may result from its use. No license is granted by implication or otherwise under any patent or patent rights of STMicroelectronics. Specifications mentioned in this publication are subject to change without notice. This publication supersedes and replaces all information previously supplied. STMicroelectronics products are not authorized for use as critical components in life support devices or systems without express written approval of STMicroelectronics.

The ST logo is a registered trademark of STMicroelectronics  
All other names are the property of their respective owners

© 2005 STMicroelectronics - All Rights Reserved

STMicroelectronics group of companies

Australia - Belgium - Brazil - Canada - China - Czech Republic - Finland - France - Germany - Hong Kong - India - Israel - Italy - Japan - Malaysia - Malta - Morocco - Singapore - Spain - Sweden - Switzerland - United Kingdom - United States of America