

TMC428 – DATA SHEET

Intelligent Triple Stepper Motor Controller with
Serial Peripheral Interfaces



TRINAMIC® Motion Control GmbH & Co. KG
Sternstraße 67
D – 20357 Hamburg
GERMANY

www.trinamic.com

1 Features

The TMC428 is a miniaturized high performance stepper motor controller. It controls up to three 2-phase stepper motors. All motors can operate independently. The TMC428 allows up to 6 bit micro step resolution – corresponding to 64 micro steps per full step – individually selectable for each motor. Once initialized, it performs all real time critical tasks autonomously based on target positions and velocities, which can be altered on-the-fly. So, an inexpensive microcontroller together with the TMC428 forms a complete motion control system. The microcontroller is free to do application specific interfacing and high level control functions. Both, the communication with the microcontroller and with one to three daisy chained stepper motor drivers take place via two separate 4 wire serial peripheral interfaces. The TMC428 directly connects to SPI™ smart power stepper motor drivers.

- Controls up to three 2-phase stepper motors
- Serial 4-wire interface for μ C with easy-to-use protocol
- Configurable interface for SPI™ motor drivers
- Different types of SPI™ stepper motor driver chips may be mixed within a single daisy chain
- Communication on demand minimizes traffic to the SPI™ stepper motor driver chain
- Programmable SPI™ data rates up to 1 Mbit/s
- Wide range for clock frequency – can use CPU clock up to 16 MHz
- Internal 24 bit wide position counters
- Full step frequencies up to 20 kHz
- Read-out facility for actual motion parameters (position, velocity, acceleration) and driver status
- Individual micro step resolution of {64, 32, 16, 8, 4, 2, 1} micro steps via built-in sequencer
- Programmable 6 bit micro step table with up to 64 entries for a quarter sine-wave period
- Built-in ramp generators for autonomous positioning and speed control
- On-the-fly change of target motion parameters (like position, velocity, acceleration)
- Automatic acceleration dependent current control (power boost)
- Low power operation: Only 1.25 mA @ 4 MHz (typ.)
- Power down mode with transparent wake-up for normal operation
- 3.3V or 5V operation with CMOS / TTL compatible IOs (all inputs Schmitt-Trigger)
- Available in ultra small 16 pin SSOP package and small 24 pin SOP package

Table of contents, table of figures, table of tables are located at the end of this datasheet.

* SPI is Trademark of Motorola, Inc.

Life support policy

TRINAMIC Motion Control GmbH & Co. KG does not authorize or warrant any of its products for use in life support systems, without the specific written consent of TRINAMIC Motion Control GmbH & Co. KG.

Life support systems are equipment intended to support or sustain life, and whose failure to perform, when properly used in accordance with instructions provided, can be reasonably expected to result in personal injury or death.

© 2004-2010, TRINAMIC Motion Control GmbH & Co. KG

Information given in this data sheet is believed to be accurate and reliable. However no responsibility is assumed for the consequences of its use nor for any infringement of patents or other rights of third parties which may result from its use.

Specifications subject to change without notice.

2 General Description

The TMC428 is a miniaturized high performance stepper motor controller with a unique price / performance ratio for both, high volume automotive and for demanding industrial motion control applications. Once initialized, the TMC428 controls up to three 2-phase stepper motors. Its low price makes it attractive also for applications, where only one or two stepper motors have to be controlled simultaneously.

The TMC428 performs all real time critical tasks autonomously. Thus a low cost microcontroller is sufficient to perform the tasks of initialization, application specific interfacing, and to specify target positions and velocities. The TMC428 allows on-the-fly change of all motion target parameters also during motion. Any other parameter may be changed at any time— also during motion—which does not make sense in any case, but this uniform access to any TMC428 register simplifies application programming. Read-back option for all internal registers simplifies programming. With its internal position counters, the TMC428 can perform up to 2^{23} steps respectively micro steps fully independent from the microcontroller. The step resolution— individually programmable for each stepper motor — ranges from full step (1 “micro step” is one full step), half step (2 “micro steps” per full step), up to 6 bit micro stepping (64 micro steps per full step) for precise positioning and noiseless stepper motor rotation (Table 8-8, page 26). Optionally, the micro step table— common for all motors —can be adapted to motor characteristics to further reduce torque ripple.

The TMC428 has got serial interfaces for communication with the microcontroller and for the stepper motor drivers. The serial interface for the microcontroller uses a fixed length of 32 bits with a simple protocol, directly connecting to SPI™ interfaces. The serial interface to the stepper motor drivers is flexibly configurable for different types— even from different vendors —with up to 64 bit length for the SPI daisy chain. TRINAMIC smart power stepper motor drivers TMC236, TMC239 and TMC246, TMC249 perfectly fit to the TMC428. Without additional hardware, drivers with same serial interface polarities of chip select and clock signals may be mixed in a single chain. To mix drivers with different serial interface polarities, additional inverters (e.g. 74HC04, 74HC14) are required. For those driver chips without serial data output, two additional variants of the TMC428 with two additional chip select outputs are available. The TMC428 sends data to the driver chain on demand only, which minimizes the interface traffic and reduces the power consumption.

Hint: Unused reference switch inputs should be pulled to ground (Figure 2-1). With this one can connect reference switches that connect to +5V resp. +3.3V when pushed. Concerning different reference switch configurations please refer to Figure 9-3, Figure 9-4, Figure 9-5.

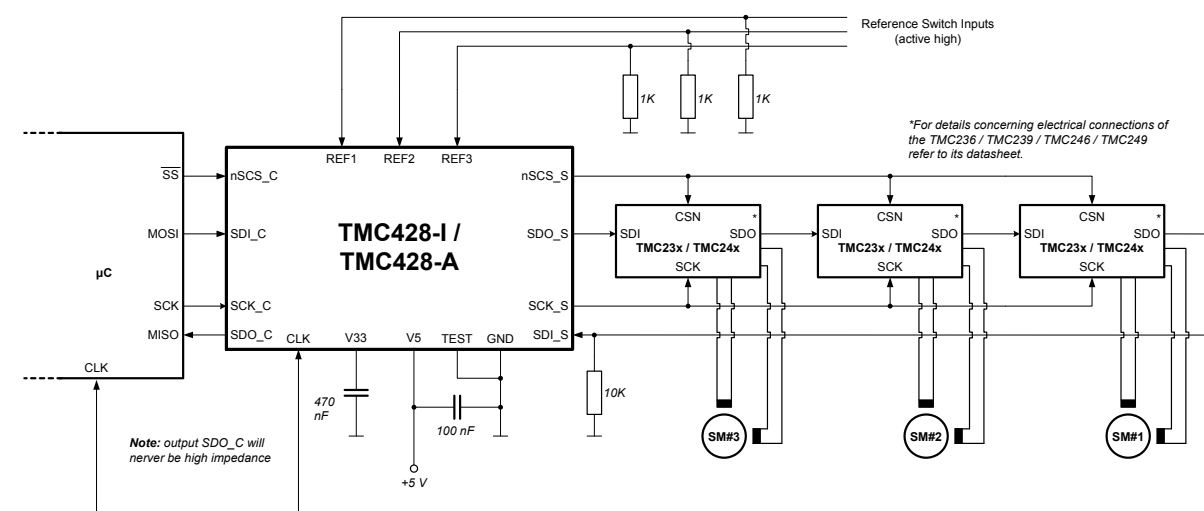

Figure 2-1: TMC428 application environment with TMC428 in SSOP16 package

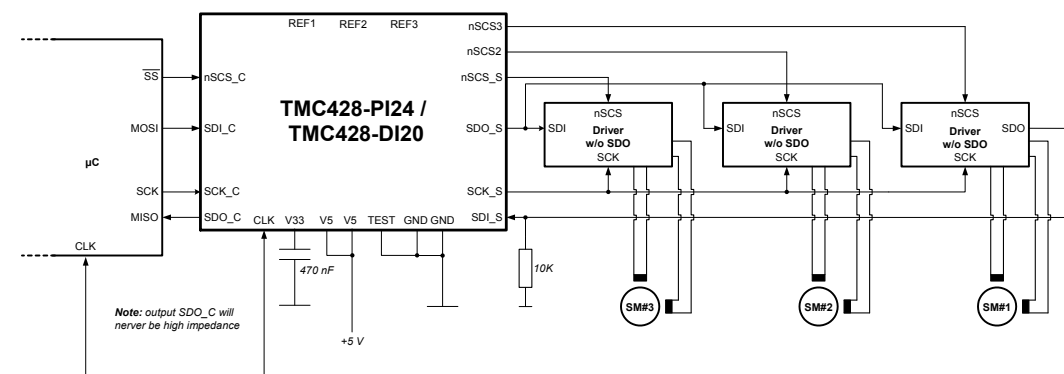

Figure 2-2: Usage of drivers without serial data output (SDO) with TMC428 in larger packages (*the DI20 package variant is not recommended for new designs)

2.1 Step Frequencies

The maximum SPITM data rate is the clock frequency divided by 16. The maximum step frequency depends on the total length of the datagrams sent to the SPITM stepper motor driver chain. At a clock frequency of 16 MHz, with a daisy chain of three SPITM stepper motor drivers of 16 bit datagram length each, the maximum *full step* frequency is $16 \text{ MHz} / 16 / (3 * 16)$. This is approximately 20 kHz and that is much higher than needed for typical stepper motors. But, the micro step rate may be higher, even if the stepper motor driver does not see all micro steps due to SPITM data rate limit, as long as the number of skipped micro steps is less than a full step. In this respect, one should remember, that at high step rates— respectively pulse rates —the differences between micro stepping and full step excitation vanishes.

2.2 Modes of Motion

The TMC428 has four different modes of motion, programmable individually for each stepper motor, named RAMP_MODE, SOFT_MODE, VELOCITY_MODE, and HOLD_MODE. For positioning applications the RAMP_MODE is most suitable, whereas for constant velocity applications the VELOCITY_MODE is. In RAMP_MODE, the user just sets the position and the TMC428 calculates a trapezoidal velocity profile and drives autonomously to the target position. During motion, the position may be altered arbitrarily. The SOFT_MODE is similar to the RAMP_MODE, but the decrease of the velocity during deceleration is done with a soft, exponentially shaped velocity profile. In VELOCITY_MODE, a target velocity is set by the user and the TMC428 takes into account user defined limits of velocity and acceleration. In HOLD_MODE, the user sets target velocities, but the TMC428 ignores any limits of velocity and acceleration, to realize arbitrary velocity profiles, controlled completely by the user. The TMC428 has capabilities to generate interrupts depending on different stepper motor conditions chosen by an interrupt mask. However, status bits sent back automatically to the microcontroller each time it sends data to the TMC428 are sufficient for polling techniques.

The TMC428 provides different modes for reference switch handling. In the default reference switch mode, the three reference switch inputs (**REF1**, **REF2**, **REF3**) are defined as left side reference switches, one for each stepper motor. In another mode, the 1st reference input (**REF1**) is defined as left reference switch input of motor number one, the 2nd reference input (**REF2**) is defined as left reference switch input of motor number two, and the 3rd reference input (**REF3**) is defined as right reference switch of stepper motor number one. In that mode, there is no reference switch input available for stepper motor three. With an external multiplexer 74HC157 any stepper motor may have a left and a right reference switch.

Many serial stepper motor drivers provide different status bits (driver active, inactive, ...) and error bits (short to ground, wire open, ...). To have access to those error bits, datagrams with a total length up to 48 bits sent back from the stepper motor driver chain to the TMC428 are buffered within two 24 bit wide registers. The microcontroller has direct access to these registers. Although, the TMC428 provides datagrams with up to 64 bits, only the last 48 bits sent back from the driver chain are buffered for read out by the microcontroller. This is because buffering of 3 times 16 bits is sufficient for a chain of three stepper motor drivers (see Figure 2-1, page 3) and most other drivers sending back up to 16 bits. For a chain of three TMC236 / TMC239 / TMC246 / TMC249 all status bits are accessible. From

the software point of view, the TMC428 provides a set of registers, accessed by a microcontroller (μC) via a serial interface in an uniform way. Each datagram contains address bits, a read-write selection bit, and data bits, to access the registers and the on-chip memory. Each time, the μC sends a datagram to the TMC428, it simultaneously receives a datagram from the TMC428. This simplifies the communication with the TMC428 and makes the programming easy. Most microcontrollers have an SPITM hardware interface, which directly connects to the serial four wire microcontroller interface of the TMC428. For microcontrollers without SPITM hardware, a software doing the serial communication is completely sufficient and can easily be implemented.

2.3 Notation of Number Systems & Notation of Two to the Power of n

Decimal numbers are used as usual without additional identification. Binary numbers are identified by a prefixed % character. Hexadecimal numbers are identified by a prefixed \$ character. So, for example the decimal number 42 in the decimal system is written as %101010 in the binary number system, and it is written as \$2A in the hexadecimal number system. With this, TMC428 datagrams are written as 32 bit numbers (e.g. \$1234ABCD = %00010010001101001010101111001101). In addition to the basic arithmetic operators (+, -, *, /) the operator *two to the power of n* is required at different sections of this data sheet. For better readability instead of 2^n the notation $2^{\wedge}n$ is used.

2.4 Signal Polarities

Per default, signals— external and internal —are high active, but the polarity of some signals is programmable to be inverted. A pre-fixed lower case 'n' indicates low active signals (e.g. nSCS_C, nSCS_S). For example the polarity of nSCS_S can be inverted by programming, but also the polarity of datagram bits can be inverted by programming (see section 9, page 27).

2.5 Units of Motion Parameters

Motion parameters position, velocity, and acceleration are given as integer values within TMC428 specific units. Section 8.14 page 26 explains how to calculate steps, steps per second, steps per second square from given TMC428 integer values. With a given stepper motor resolution one can calculate physical units for angle, angular velocity, angular acceleration.

2.6 Representation of Signed Values by Two's Complement

Those motion parameters that have to cover negative and positive motion direction as well are processed as signed numbers represented by two's complement as usual. Signed motion parameters are x_target, x_actual, v_target, v_actual, a_actual, a_threshold (pls. refer section 8.9, page 18). Limit motion parameters as v_min, v_max, a_max, are represented as unsigned binary numbers.

2.7 Tables of Contents

A table of contents, a table of figures, and a table of tables are located at the end of the data sheet.

3 Package Variants

The TMC428 is available in three different package variants, qualified for the industrial temperature range. An additional variant is available for the automotive temperature range. The package outlines and dimensions are included within this data sheet (page 45-47.)

| part number | Package | JEDEC Drawing |
|-------------|--|-------------------|
| TMC428-I | SSOP16 – 150 mils, 16 pins, plastic package, industrial (-40°C ... +85°C) RoHS compliant since date code 0424 (YYWW = WW 24 / 2004) | MO-137 (150 mils) |
| TMC428-PI24 | SOP24 – 300 mils, 24 pins, plastic package, industrial (-40°C ... +85°C) RoHS compliant since date code 0518 (YYWW = WW 18 / 2005) | MS-013 (300 mils) |
| TMC428-A | SSOP16 – 150 mils, 16 pins, plastic package, automotive (-40°C ... +125°C) | MO-137 (150 mils) |
| TMC428-DI20 | DIL20 – 300 mils, 20 pins, plastic package, industrial (-40°C ... +85°C) [This package variant is not recommended for new designs] | MS-001 (300 mils) |

Table 3-1: TMC428 package variants

4 Pinning

There are three package variants of the TMC428 available. The smaller SSOP16 package is sufficient for TRINAMIC stepper motor drivers (TMC236 / TMC239 / TMC246 / TMC249) with up to three drivers in a chain and for most SPI™ stepper motor drivers from other vendors. Some SPI™ stepper motor drivers from other vendors have no serial data output and cannot simply be arranged in a daisy chain to drive more than one motor. The two package variants SOP24 and DIL20 have two additional driver selection outputs (**nSCS2**, **nSCS3**) for those stepper motor drivers without serial data output. All inputs are Schmitt-Trigger. Possibly unused inputs (**REF1**, **REF2**, **REF3**, **SDI_S**) need to be connected to ground.

Hint: Preferably, long wires to the reference switch inputs (REF1, REF2, REF3) should be avoided. For long wires, a low pass filter for spike suppression should be provided (pls. refer the TMC428 evaluation board schematic as an example).

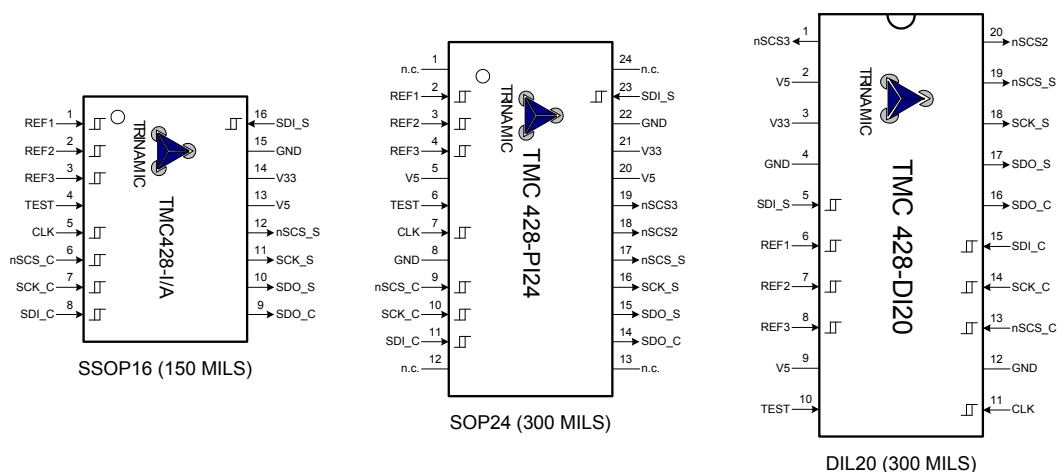

Figure 4-1: TMC428 pin out (**the DIL20 package variant is not recommended for new designs*)

| Pin | SSOP16 | SOP24 | DIL20* | In/Out | Description |
|--------------|--------|---------------|--------|--------|--|
| Reset | - | - | - | - | internal power-on reset |
| CLK | 5 | 7 | 11 | I | clock input |
| nSCS_C | 6 | 9 | 13 | I | low active SPI chip select input driven from μ C |
| SCK_C | 7 | 10 | 14 | I | serial data clock input driven from μ C |
| SDI_C | 8 | 11 | 15 | I | serial data input driven from μ C |
| SDO_C / nINT | 9 | 14 | 16 | O | serial data output to μ C input / multiplexed nINTERRUPT output if communication with μ C is idle (resp. nSCS_C = 1) Important Note: SDO_C will never be high impedance, but this function can added with a single gate 74HCT1G125 (pls. refer Figure 4, page 9) |
| nSCS_S | 12 | 17 | 19 | O | SPI chip select signal to stepper motor driving chain |
| nSCS2 | - | 18 | 20 | O | SPI chip select signal (SOP24 & DIL20 package only) |
| nSCS3 | - | 19 | 1 | O | SPI chip select signal (SOP24 & DIL20 package only) |
| SCK_S | 11 | 16 | 18 | O | serial data clock output to SPI stepper motor driver chain |
| SDO_S | 10 | 15 | 17 | O | serial data output to SPI stepper motor driver chain |
| SDI_S | 16 | 23 | 5 | I | serial data input from SPI stepper motor driver chain Note: pull-up/-down resistor at SDI_S avoids high impedance |
| REF1 | 1 | 2 | 6 | I | reference switch input 1 |
| REF2 | 2 | 3 | 7 | I | reference switch input 2 |
| REF3 | 3 | 4 | 8 | I | reference switch input 3 |
| V5 | 13 | 5, 20 | 2, 9 | | +5V supply / +3.3V supply |
| V33 | 14 | 21 | 3 | | 470 nF ceramic capacitor pin / +3.3V supply |
| GND | 15 | 8, 22 | 4, 12 | | ground |
| TEST | 4 | 6 | 10 | I | must be connected to GND as close as possible to the chip |
| n.c. | - | 1, 12, 13, 24 | - | - | not connected |

Table 4-1: TMC428 pin out (**the DIL20 package variant is not recommended for new designs*)

5 Functional Description and Block Diagram

From the software point of view, the TMC428 provides a set of registers of different units and on-chip RAM (see Figure 5-1), accessed via the serial μ C interface in an uniform way. The serial interface uses just a simple protocol with fixed length datagrams for read and write access. The serial interface to the stepper motor driver chain has to be configured by an initialization sequence which writes the configuration into the on-chip RAM. Once configured the serial driver interface works autonomously. The internal multiple port RAM controller of the TMC428 takes care of access scheduling. So, the user may read and write registers and on-chip RAM at any time. The registers hold global configuration parameters and the motion parameters. The on-chip RAM stores the configuration of the serial driver interface and the micro step table.

The ramp generator monitors the motion parameters stored in its registers and calculates velocity profiles controlling the pulse generator. The pulse generator then generates step pulses taking into account user defined motion parameter limits. The serial driver interface sends datagrams to the stepper motor driver chain whenever a step pulse comes. The micro step unit (including sequencer) processes step pulses from the pulse generator— representing micro steps, half steps, or full steps depending on the selected step resolution —and makes the results available to the serial driver interface. The ramp generator also interfaces the reference switch inputs. Unused reference switches have to be connected to ground. A pull-down resistor is necessary at the SDI_S input of the TMC428 for those serial peripheral interface stepper motor drivers that set their serial data output to high impedance 'Z' while inactive.

The interrupt controller continuously watches reference switches and ramp generator conditions and generates an interrupt if required. To save pins, the interrupt signal is multiplexed to the SDO_C signal. This output becomes the low active interrupt signal called **nINT** while **nSCS_C** is high (see Figure 6-1, page 8). So, if the microcontroller disables the interrupt during access to the TMC428 and enables the interrupt otherwise, the multiplexed interrupt output of the TMC428 behaves like a dedicated interrupt output. For polling, the TMC428 sends the status of the interrupt signal to the microcontroller with each datagram.

To drive a stepper motor to a new target position, one just has to write the target position into the associated register by sending a datagram to the TMC428. To run a stepper motor with a target velocity, one just has to write the velocity into the register assigned to the stepper motor.

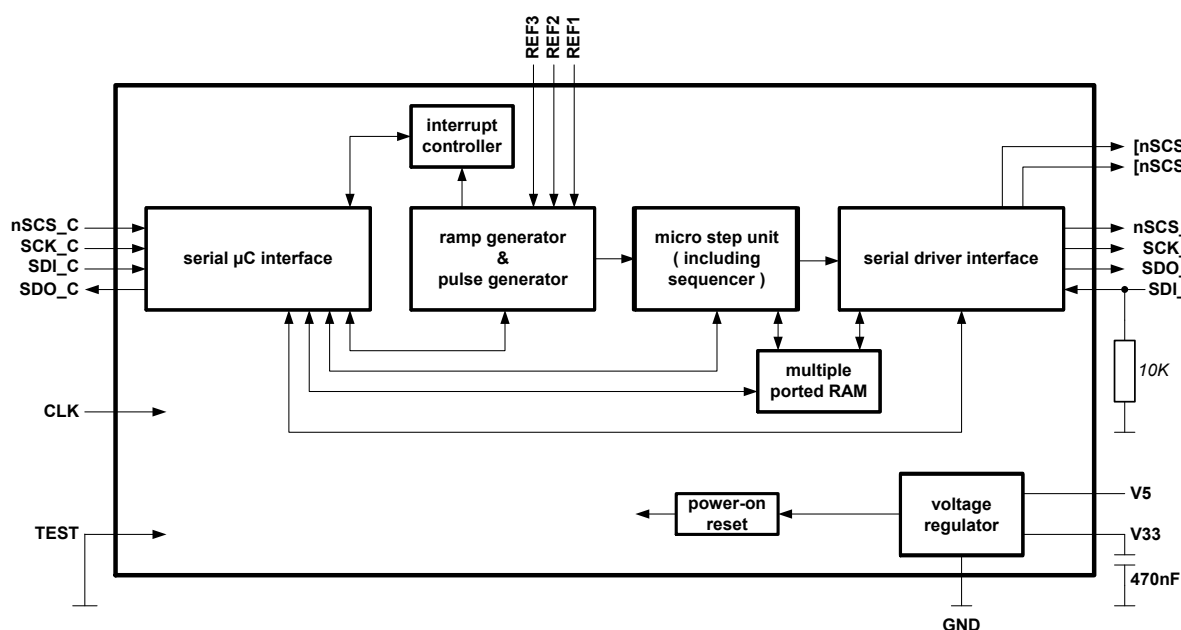

Figure 5-1: TMC428 functional block diagram

6 Serial Peripheral Interfaces

The four pins named SCS_C, SCK_C, SDI_C, SDO_C form the serial microcontroller interface of the TMC428. The communication between the microcontroller and the TMC428 takes place via 32 bit datagrams of fixed length. Concerning communication, the μ C is the master and the TMC428 is the slave, with the TMC428 in turn being the master for the stepper motor driver daisy chain. Similar to the microcontroller interface, the TMC428 uses a four wire serial interface for communication with the stepper motor driver daisy chain. The four pins named SCS_S, SCK_S, SDO_S, SDI_S form the serial stepper motor driver interface. Stepper motor drivers with parallel inputs can be used in connection with the TMC428 with some additional glue logic.

6.1 Automatic Power-On Reset

The TMC428 performs an automatic power-on reset. For details see section Power-On-Reset, page 50. The TMC428 cannot be accessed before the power-on-reset is completed and the clock is stable. All register bits are initialized with '0' during power on reset, except the SPI clock pre-divider `clk2_div` (see section 9.7, page 29) that is initialized with 15.

6.2 Serial Peripheral Interface for μ C

The serial microcontroller interface of the TMC428 behaves as a simple 32 bit shift register. It shifts serial data SDI_C in with the rising edge of the clock signal SCK_C and copies the content of the 32 bit shift register with the rising edge of the selection signal nSCS_C into a buffer register. The serial interface of the TMC428 immediately sends back data read from registers or read from internal RAM via the signal SDO_C. The signal SDO_C can be sampled with the rising edge of SCK_C, but SDO_C becomes valid at least four CLK clock cycles after SCK_C becomes low as outlined in the timing diagram Figure 6-1. For detailed timing parameters see Table 6-1, page 10. The SPI signals from the μ C interface may be asynchronous to the clock signal CLK of the TMC428.

Because of on-the-fly processing of the input data stream, the serial microcontroller interface of the TMC428 requires the serial data clock signal SCK_C to have a minimum low / high time of three clock cycles. The data signal SDI_C driven by the microcontroller has to be valid at the rising edge of the serial data clock input SCK_C. The maximum duration of the serial data clock period is unlimited. While the μ C interface of the TMC428 is idle, the SDO_C signal is the (active low) interrupt status nINT of the integrated interrupt controller of the TMC428. The timing of the multiplexed interrupt status signal nINT is characterized by the parameters tIS as tSI (see Table 6-1, page 10).

Hint: If the microcontroller and the TMC428 work on different clock domains that run asynchronous to each other, the timing of the SPI interface of the microcontroller should be made conservative in the way that the length of one SPI clock cycle equals 8 or more clock cycles of the TMC428 clock CLK. This make the system robust concerning frequency drift, jitter, etc.

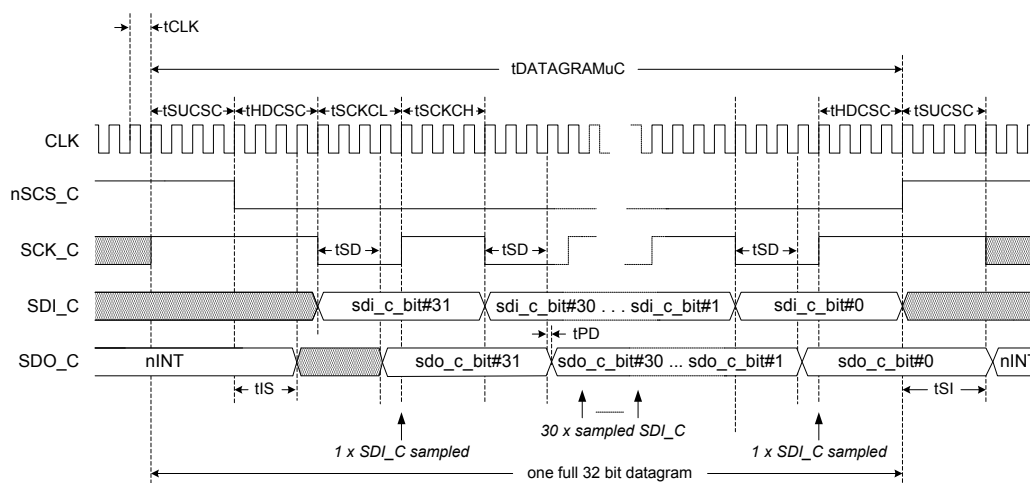

Figure 6-1: Timing diagram of the serial μ C interface

A complete serial datagram frame has a fixed length of 32 bit. While the data transmission from the microcontroller to the TMC428 is idle, the low active serial chip select input nSCS_C and also the serial data clock signal SCK_C are set to high. While the signal nSCS_C is high, the TMC428 assigns the status of the internal low active interrupt signal named nINT to the serial data output SDO_C (see Figure 6-1). The serial data input SDI_C of the TMC428 has to be driven by the microcontroller.

Important Hint: In contrast to most other SPITM compatible devices, the SDO_C signal of the TMC428 is always driven. So, it will never be high impedance 'Z'. If high impedance is required for the SDO_C connected to the microcontroller, it can simply be realized using a single gate 74HCT1G125.

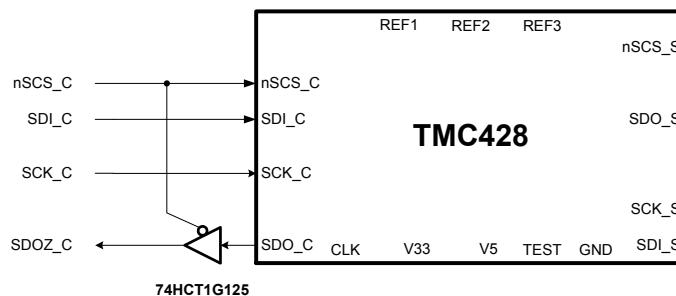

Figure 4 : Making the TMC428 SDO_C output high impedance with single gate 74HCT1G125

The signal nSCS_C has to be high for at least three clock cycles before starting a datagram transmission. To initiate a transmission, the signal nSCS_C has to be set to low. Three clock cycles later the serial data clock may go low. The most significant bit (MSB) of a 32 bit wide datagram comes first and the least significant bit (LSB) is transmitted as the last one. A data transmission is finished by setting nSCS_C high three or more CLK cycles after the last rising SCK_C slope. So, nSCS_C and SCK_C change in opposite order from low to high at the end of a data transmission as these signals change from high to low at the beginning. The timing of the serial microcontroller interface is outlined in Figure 6-1.

6.3 Serial Peripheral Interface to Stepper Motor Driver Chain

The timing of the serial stepper motor interface is similar to that of the microcontroller interface. It directly connects to SPITM smart power stepper motor drivers. The SPITM datagram is configurable individually for each stepper motor driver chip of the daisy chain. It is simply configurable by sending a fixed sequence of datagrams to the TMC428 to initialize it after power-up. Once initialized, the TMC428 autonomously generates the datagrams for the stepper motor driver daisy chain without any additional interventions of the microcontroller.

The SPITM datagram for each stepper motor driver is composed of so called *primary signal bits* provided by the micro step unit of the TMC428 individually for each stepper motor. Each primary signal bit is represented by a five bit code word called *primary signal code*. The order of primary signal bits forming the SPITM datagrams for the stepper motor driver daisy chain is defined by the order of primary signal code words in the configuration RAM area.

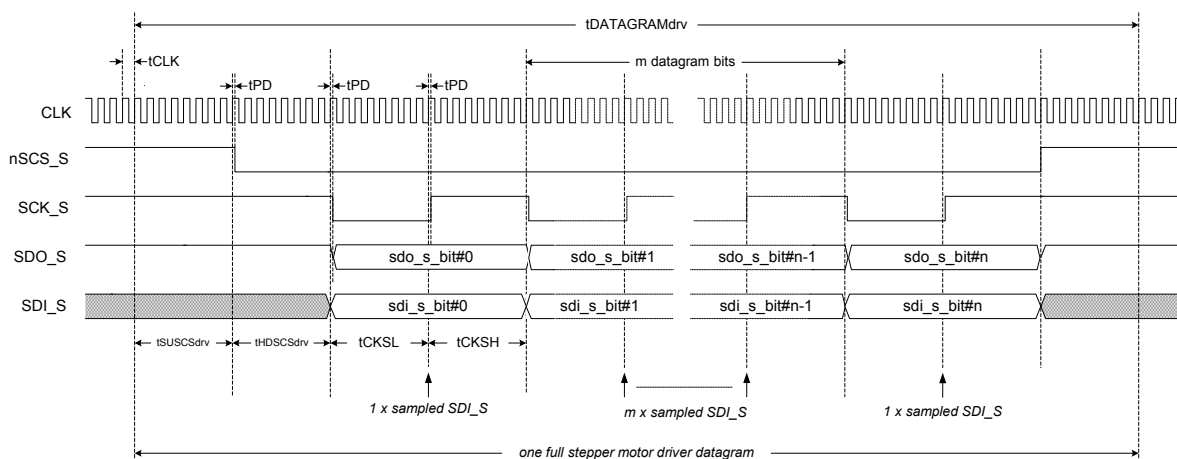

Figure 6-3: Timing diagram of the serial stepper motor driver interface

To switch to the next motor, an additional bit called *next motor bit* (NxM-Bit) is prefixed to the five bit wide primary signal code words. So, the total data word width is six bit. Each NxM-Bit effects an increment of an internal stepper motor address until the processing for all stepper motors within the daisy chain is completed. A parameter called **LSMD** (last stepper motor driver) defines the total number of stepper motors within the daisy chain. So, the codes written into the serial interface configuration RAM area represent the mapping of control signals provided by the micro step units to control bits of the drivers. It might be noted here, that configuring the serial driver interface is much easier as it might seem here. It is explained in detail, illustrated by examples below (see section 11 Stepper Motor Driver Datagram Configuration, page 36).

| Symbol | Parameter | Min | Typ | Max | Unit |
|-------------|---|--------------------|-----|----------|-------------|
| tSUCSC | Setup Clocks for nSCS_C | 3 | | ∞ | CLK periods |
| tHDCSC | Hold Clocks for nSCS_C | 3 | | ∞ | CLK periods |
| tSCKCL | Serial Clock Low | 3 | | ∞ | CLK periods |
| tSCKCH | Serial Clock High | 3 | | ∞ | CLK periods |
| tSD | SDO_C valid after SCK_C low | 2.5 | | 3.5 | CLK periods |
| tIS | nINTERRUPT status valid after nSCS_C low | 2.5 | | | CLK periods |
| tSI | SDO_C valid after nSCS_C high | | | 4.5 | CLK periods |
| tDAMAGRAMuC | Datagram Length | $3+3 + 32*6 = 198$ | | ∞ | CLK periods |
| tDAMAGRAMuC | Datagram Length | 12.375 | | ∞ | μ s |
| fCLK | Clock Frequency | 0 | | 16 | MHz |
| tCLK | Clock Period $tCLK = 1 / fCLK$ | 62.5 | | ∞ | ns |
| tPD | CLK-rising-edge-to-Output Propagation Delay | | 5 | | ns |

Table 6-1: Timing characteristics of the serial microcontroller interface

| Symbol | Parameter | Min | Typ | Max | Unit |
|--------------|----------------------------------|-------------------|-----|-------------------------|-------------|
| tSUSCSdrv | | 8 | 16 | 256 | CLK periods |
| tHDCSdrv | | 8 | 16 | 256 | CLK periods |
| tCKSL | | 8 | 16 | 256 | CLK periods |
| tCKSH | | 8 | 16 | 256 | CLK periods |
| tDAMAGRAMdrv | Datagram Length | $8+8+1*16+8+8=48$ | | $512+64*512+512= 33792$ | CLK periods |
| tDAMAGRAMdrv | Datagram Length @ fCLK = 16 MHz | 3 | | 2112 | μ s |
| tPD | CLK-rising-edge to Outputs Delay | | 5 | | ns |

Table 6-2: Timing characteristics of the serial stepper motor driver interface

| MSB | | 32 bit DATAGRAM sent back from the TMC428 to μ C via pin SDO_C | | | | | | | | | | | | | | | | | | | | | | | | LSB | | | | | | | | | | | |
|-------------|------|--|-----|-----|-------|-------|-------|---|---|-----------|---|---|---|---|---|---|---|---|---|---|---|---|---|---|---|-----|---|---|---|---|---|---|---|---|---|---|--|
| 3 | 3 | 2 | 2 | 2 | 2 | 2 | 2 | 2 | 2 | 2 | 2 | 2 | 1 | 1 | 1 | 1 | 1 | 1 | 1 | 1 | 1 | 1 | 1 | 1 | 1 | 1 | 9 | 8 | 7 | 6 | 5 | 4 | 3 | 2 | 1 | 0 | |
| STATUS BITS | | | | | | | | | | DATA BITS | | | | | | | | | | | | | | | | | | | | | | | | | | | |
| INT | CDGW | SM3 | SM2 | SM1 | | | | | | | | | | | | | | | | | | | | | | | | | | | | | | | | | |
| | | RS3 | RS2 | RS1 | xEQt3 | xEQt2 | xEQt1 | | | | | | | | | | | | | | | | | | | | | | | | | | | | | | |

Table 6-4: 32 bit DATAGRAM structure received by μ C (MSB received first)

The status bit **INT** is the internal high active interrupt controller status output signal. Handling of interrupt conditions without using interrupt techniques is possible by polling this status bit. The interrupt signal is also directly available at the SDO_C pin of the TMC428 if nSCS_C is high. The pin SDO_C may directly be connected to an interrupt input of the microcontroller. Since the SDO_C / nINT output is multiplexed, the microcontroller has to disable its interrupt input while it sends a datagram to the TMC428, because the SDO_C signal— driven by the TMC428 —alternates during datagram transmission. For initialization purposes, the TMC428 enables direct communication between the microcontroller and the stepper motor driver chain by sending a so called *cover datagram* (see sections 9.2 and 9.3). The position **cover_position** and actual length **cover_len** of a cover datagram is specified by writing them into a common register. Writing an up to 24 bit wide cover datagram to the register **cover_datagram** will fade in that cover datagram into the next datagram sent to the stepper motor driver chain. As a default setting, the TMC428 only sends datagrams on demand. Optionally, continuous update— periodic sending of datagrams to the stepper motor driver chain —is also possible. So, the status bit named **CDGW** (cover datagram waiting) is a handshake signal for the microcontroller in regard to the datagram covering mechanism. This feature is necessary to enable direct data transmission from a microcontroller to the stepper motor driver chips for initialization purposes. The **CDGW** status bit also gives the status of the **datagram_high_word** and **datagram_low_word** (see section 9.1).

The status bits **RS3**, **RS2**, **RS1** represent the settings of the reference switches. But, the reference switch inputs REF3, REF2, REF1 are not mapped directly to these status bits. Rather, the reference switch inputs may have different functions, depending on programming (see pages 22 – 24). The three status bits **xEQt3**, **xEQt2**, **xEQt1** indicate individually for each stepper motor, if it has reached its target position. The status bits **RS3**, **RS2**, **RS1** and bits **xEQt3**, **xEQt2**, **xEQt1** can trigger an interrupt or enable simple polling techniques.

6.5 Simple Datagram Examples

The % prefix– normally indicating binary representation in this data sheet –is omitted for the following datagram examples. Assuming, one would like to write (RW=0) to a register (RRS=0) at the address %001101 the following data word %0000 0000 0000 0001 0010 0011, one would have to send the following 32 bit datagram

```
000110100000000000000000100100011
```

to the TMC428. With inactive interrupt (INT=0), no cover datagram waiting (CDGW=0), all reference switches inactive (RS3=0, RS2=0, RS1=0), and all stepper motors at target position (xEQt3=1, xEq2=1, xEq1=1) the status bits would be %10010101 the TMC428 would send back the 32 bit datagram:

```
10010101000000000000000000000000
```

To read (RW=1) back the register written before, one would have to send the 32 bit datagram

```
00011011000000000000000000000000
```

to the TMC428 and would get back from it the datagram

```
100101010000000000000000100100011.
```

Write (RW=0) access to on-chip RAM (RRS=1) to an address %111111 occurs similar to register access, but with RRS=1. To write two 6 bit data words %100001 and %100011 to successive pair-wise RAM addresses %1111110 and %1111111 (%100001 to %1111110 and %100011 to %1111111) which are commonly addressed by one datagram (see pages 14 and 35), one would have to send the datagram

```
11111110000000000010001100100001.
```

To read (rw=1) from that on-chip memory address, one would have to send the datagram

```
11111111000000000000000000000000.
```

7 Address Space Partitions

The address space is partitioned in different ranges. Each of the up to three stepper motors has a set of registers individually assigned to it, arranged within a contiguous address space. An additional set of registers within the address space holds some global parameters common for all stepper motors. One dedicated global parameter register is essential for the configuration of the serial four wire stepper motor driver interface. One half of the on-chip RAM address space holds the configuration parameters for the stepper motor driver chain. The other half of the on-chip RAM address space is provided to store a micro step table if required. The first seven datagram bits (*sdi_c_bit#31* and *sdi_c_bit#30* ... *sdi_c_bit#25*, respectively *RRS* and *ADDRESS*) address the whole address space of the TMC428.

| address ranges (incl. RRS) | assignment | |
|----------------------------|--|------------------------------|
| %000 0000 ... %000 1111 | 16 registers for stepper motor #1 | registers with up to 24 bits |
| %001 0000 ... %001 1111 | 16 registers for stepper motor #2 | |
| %010 0000 ... %010 1111 | 16 registers for stepper motor #3 | |
| %011 0000 ... %011 1110 | 15 common registers | |
| | %011 1111 | 1 global parameter register |
| %100 0000 ... %101 1111 | 32 addresses of 2x6 bit for driver chain configuration | RAM 128x6 bit |
| %110 0000 ... %111 1111 | 32 addresses of 2x6 bit for microstep table | |

Table 7-1: TMC428 address space partitions

The stepper motors are controlled directly by writing motion parameters into associated registers. Only one register write access is necessary to change a target motion parameter. E.g. to change the target position of one stepper motor, the microcontroller has to send only one 32 bit datagram to the TMC428. The same is true for changing a target velocity. Some parameters are packed together in a single data word at a single address. Those parameters— initialized once and unchanged during operation —have to be changed commonly. Access to on-chip RAM addresses concern two successive RAM addresses. So, always two data words are modified with each write access to the on-chip RAM. Once initialized after power-up, the content of the RAM is usually left unchanged.

7.1 Read and Write

Read and write access is selected by the RW bit (*sdi_c_bit#24*) of the datagram sent from the μ C to the TMC428. The on-chip configuration RAM and the registers are writeable with read-back option. Some addresses are read-only. Write access (**RW=0**) to some of those read-only registers triggers additional functions, explained in detail later.

7.2 Register Set

The register address mapping is given in Table 7-2 on page 15. These registers are initialized internally during power-up. During power-up initialization, the TMC428 sends no datagrams to the stepper motor driver chain.

Note: The RAM has to be initialized before writing target parameters to the register set.

7.3 RAM Area

The RAM address mapping is given in Table 10-1 page 35. The on-chip RAM is *NOT* initialized internally during power-up. This has to be done by the microcontroller before operation.

Note: There are unused addresses within the address space of the TMC428. Access to these addresses has no effect. However, access should be avoided, because this address space may be used for future devices.

Important Hint: All register bits are initialized with '0' during power on reset, except the SPI clock pre-divider **clk2_div** (see section 9.7, page 29) that is initialized with 15.

| 32 bit DATAGRAM sent from a µC to the TMC428 via pin SDI_C | | | | | | | | | | | | | | | | | | | | | | | | | | | | | | | | | | | | | | | | | | | | | | | | | | | | | | | | | | | | | | | | | | | | | | |
|--|---|---------|---|-----|---|--------------------|------|---|----------|----------------------------|-------------|---|---|---|----|----------|---|---|---|----|----------------|---|------|---|----|-----------------|---|------|---|----|---|---|--|---|----|---|--|---|--|----|--|---|--|---|--|--|--|--|--|--|--|--|--|--|--|--|--|--|--|--|--|--|--|--|--|--|--|--|--|--|
| RRS | | ADDRESS | | | | RW | DATA | | | | | | | | | | | | | | | | | | | | | | | | | | | | | | | | | | | | | | | | | | | | | | | | | | | | | | | | | | | | | | | |
| 3 | 3 | 2 | 2 | 2 | 2 | 2 | 2 | 2 | 2 | 2 | 1 | 1 | 1 | 1 | 1 | 1 | 1 | 1 | 1 | 1 | 1 | 9 | 8 | 7 | 6 | 5 | 4 | 3 | 2 | 1 | 0 | | | | | | | | | | | | | | | | | | | | | | | | | | | | | | | | | | | | | | | |
| 1 | 0 | 9 | 8 | 7 | 6 | 5 | 4 | 3 | 2 | 1 | 0 | 9 | 8 | 7 | 6 | 5 | 4 | 3 | 2 | 1 | 0 | | | | | | | | | | | | | | | | | | | | | | | | | | | | | | | | | | | | | | | | | | | | | | | | | |
| 0 | | smda | | IDX | | | | three stepper motor register sets (SMDA={00, 01, 10}) | | | | | | | | | | | | | | | | | | | | | | | | | | | | | | | | | | | | | | | | | | | | | | | | | | | | | | | | | | | | | | |
| | | 0 | 0 | 0 | 0 | 0 | 0 | x_target | | | | | | | | | | | | | | | | | | | | | | | | | | | | | | | | | | | | | | | | | | | | | | | | | | | | | | | | | | | | | | |
| | | | | 0 | 0 | 0 | 1 | x_actual | | | | | | | | | | | | | | | | | | | | | | | | | | | | | | | | | | | | | | | | | | | | | | | | | | | | | | | | | | | | | | |
| | | | | 0 | 0 | 1 | 0 | v_min | | | | | | | | | | | | | | | | | | | | | | | | | | | | | | | | | | | | | | | | | | | | | | | | | | | | | | | | | | | | | | |
| | | | | 0 | 0 | 1 | 1 | v_max | | | | | | | | | | | | | | | | | | | | | | | | | | | | | | | | | | | | | | | | | | | | | | | | | | | | | | | | | | | | | | |
| | | | | 0 | 1 | 0 | 0 | v_target | | | | | | | | | | | | | | | | | | | | | | | | | | | | | | | | | | | | | | | | | | | | | | | | | | | | | | | | | | | | | | |
| | | | | 0 | 1 | 0 | 1 | v_actual | | | | | | | | | | | | | | | | | | | | | | | | | | | | | | | | | | | | | | | | | | | | | | | | | | | | | | | | | | | | | | |
| | | | | 0 | 1 | 1 | 0 | a_max | | | | | | | | | | | | | | | | | | | | | | | | | | | | | | | | | | | | | | | | | | | | | | | | | | | | | | | | | | | | | | |
| | | | | 0 | 1 | 1 | 1 | a_actual | | | | | | | | | | | | | | | | | | | | | | | | | | | | | | | | | | | | | | | | | | | | | | | | | | | | | | | | | | | | | | |
| | | | | 1 | 0 | 0 | 0 | is_agtat | is_aleat | is_v0 | a_threshold | | | | | | | | | | | | | | | | | | | | | | | | | | | | | | | | | | | | | | | | | | | | | | | | | | | | | | | | | | | |
| | | | | 1 | 0 | 0 | 1 | 1 | | | | | | | | | | | | | | | pmul | | | | | pdiv | | | | | | | | | | | | | | | | | | | | | | | | | | | | | | | | | | | | | | | | | | |
| | | 1 | 0 | 1 | 0 | ip | | | | | | | | | | | | | | | ref_conf | | | | | rm | | | | | | | | | | | | | | | | | | | | | | | | | | | | | | | | | | | | | | | | | | | | |
| | | 1 | 0 | 1 | 1 | | | | | | | | | | | | | | | | interrupt_mask | | | | | interrupt_flags | | | | | | | | | | | | | | | | | | | | | | | | | | | | | | | | | | | | | | | | | | | | |
| | | 1 | 1 | 0 | 0 | pulse_div | | | | | | | | | | ramp_div | | | | | usrs | | | | | | | | | | | | | | | | | | | | | | | | | | | | | | | | | | | | | | | | | | | | | | | | | |
| | | 1 | 1 | 0 | 1 | dx_ref_tolerance | | | | | | | | | | | | | | | | | | | | | | | | | | | | | | | | | | | | | | | | | | | | | | | | | | | | | | | | | | | | | | | | |
| | | 1 | 1 | 1 | 0 | x_latched | | | | | | | | | | | | | | | | | | | | | | | | | | | | | | | | | | | | | | | | | | | | | | | | | | | | | | | | | | | | | | | | |
| | | 1 | | 1 | | JDX | | | | common registers (SMDA=11) | | | | | | | | | | | | | | | | | | | | | | | | | | | | | | | | | | | | | | | | | | | | | | | | | | | | | | | | | | | | |
| | | | | | | datagram_low_word | | | | | | | | | | | | | | | | | | | | | | | | | | | | | | | | | | | | | | | | | | | | | | | | | | | | | | | | | | | | | | | | |
| | | | | | | datagram_high_word | | | | | | | | | | | | | | | | | | | | | | | | | | | | | | | | | | | | | | | | | | | | | | | | | | | | | | | | | | | | | | | | |
| | | | | | | cw | | | | | | | | | | | | | | | cover_position | | | | | cover_len | | | | | | | | | | | | | | | | | | | | | | | | | | | | | | | | | | | | | | | | | | | | |
| cover_datagram | | | | | | | | | | | | | | | | | | | | | | | | | | | | | | | | | | | | | | | | | | | | | | | | | | | | | | | | | | | | | | | | | | | | | | |
| power-down | | | | | | | | | | | | | | | | | | | | | | | | | | | | | | | | | | | | | | | | | | | | | | | | | | | | | | | | | | | | | | | | | | | | | | |
| | | | | | | | | | | | | | | | i3 | | | | | r3 | | | | | i2 | | | | | r2 | | | | | i1 | | | | | r1 | | | | | | | | | | | | | | | | | | | | | | | | | | | | | | |
| 1 | | 1 | | 1 | | 1 | | 1 | | 1 | | 1 | | 1 | | 1 | | 1 | | 1 | | 1 | | 1 | | 9 | | 8 | | 7 | | 6 | | 5 | | 4 | | 3 | | 2 | | 1 | | 0 | | mot1r refmux cont_update clk2_div cs_CoMInd DAC_AB FD_AB PH_AB SCK_S nSCS_S LSMD | | | | | | | | | | | | | | | | | | | | | | | | |
| | | | | | | | | | | | | | | | | | | | | | | | | | | | | | | | | | | | | | | | | | | | | | | polarities | | | | | | | | | | | | | | | | | | | | | | | | |
| | | | | | | | | | | | | | | | | | | | | | | | | | | | | | | | | | | | | | | | | | | | | | | | | | | | | | | | | | | | | | | | | | | | | | | |
| | | | | | | | | | | | | | | | | | | | | | | | | | | | | | | | | | | | | | | | | | | | | | | | | | | | | | | | | | | | | | | | | | | | | | | |
| RRS | | ADDRESS | | | | RW | DATA | | | | | | | | | | | | | | | | | | | | | | | | | | | | | | | | | | | | | | | | | | | | | | | | | | | | | | | | | | | | | | | |
| 3 | 3 | 2 | 2 | 2 | 2 | 2 | 2 | 2 | 2 | 1 | 1 | 1 | 1 | 1 | 1 | 1 | 1 | 1 | 1 | 1 | 1 | 9 | 8 | 7 | 6 | 5 | 4 | 3 | 2 | 1 | 0 | | | | | | | | | | | | | | | | | | | | | | | | | | | | | | | | | | | | | | | |
| 1 | 0 | 9 | 8 | 7 | 6 | 5 | 4 | 3 | 2 | 1 | 0 | 9 | 8 | 7 | 6 | 5 | 4 | 3 | 2 | 1 | 0 | | | | | | | | | | | | | | | | | | | | | | | | | | | | | | | | | | | | | | | | | | | | | | | | | |

Table 7-2: TMC428 register address mapping

8 Register Description

The registers hold binary coded numbers. Some are unsigned (positive) numbers, some are signed numbers in two's complement, and some are control bits or single flags. The functionality of different registers depends on the ramp mode (s. page 22).

8.1 x_target (IDX=%0000)

This register holds the current target position in units of full steps, respectively micro steps. The unit of the target position depends on the setting of the associated micro step resolution register **usrs**. If the difference $x_target - x_actual$ is unequal zero, the TMC428 moves the stepper motor in that direction of x_target so that the difference becomes zero. The condition $|x_target - x_actual| < 2^{23}$ must be satisfied for motion into the correct direction. Both, target position x_target and current position x_actual may be altered on the fly. Usually x_target is modified to start a positioning. To move from one position to another, the ramp generator of TMC428 automatically generates ramp profiles in consideration of the velocity limits v_min and v_max and acceleration limit a_max .

Note: The registers x_target , x_actual , v_min , v_max , and a_max are initialized with zero after power up. Thus, no step pulses are generated because motion is prohibited.

8.2 x_actual (IDX=%0001)

The current position of each stepper motor is available by read out of the registers called x_actual . The actual position can be overwritten by the microcontroller. This feature is for reference switch position calibration under control of the microcontroller.

8.3 v_min (IDX=%0010)

This register holds the absolute value of the velocity at or below which the stepper motor can be stopped abruptly. The parameter v_min is relevant only for deceleration while reaching a target position. It should be set greater than zero. This control value allows to reach the target position faster because the stepper motor is not slowed down below v_min before the target is reached. Also consider, that due to the finite numerical representation of integral relations, the target position can not be reached exactly, if the calculated velocity is less than one, before the target is reached. So, setting v_min to at least one assures reaching each target position exactly. The unit of velocity parameters (v_max , v_target , and v_actual) is steps per time unit. The scale of velocity parameters (v_min , v_max , v_target , v_actual) is defined by the parameter **pulse_div** (see page 26 for details) and depends on the clock frequency of the TMC428.

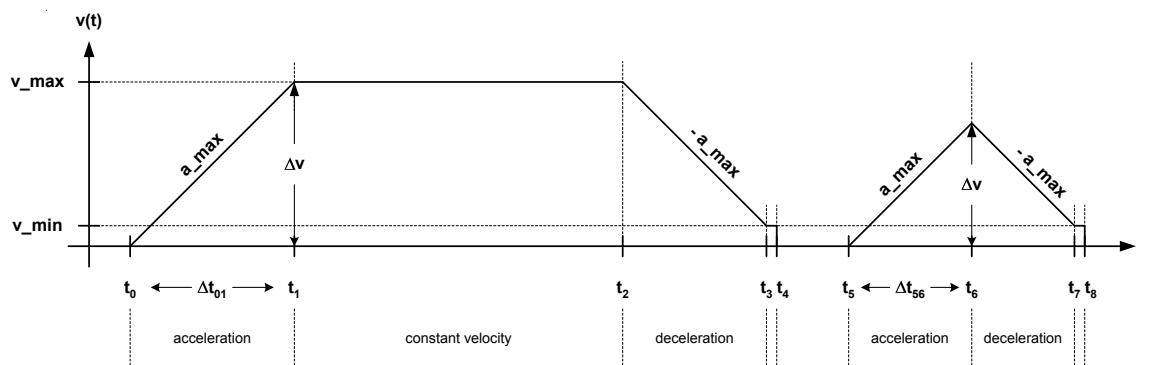

Figure 8-1: Velocity ramp parameters and velocity profiles

8.4 v_max (IDX=%0011)

This parameter sets the maximum motor velocity. The absolute value of the velocity will not exceed this limit, except if the limit **v_max** is changed during motion to a value below the current velocity.

Note: To set target position **x_target** and current position **x_actual** to an equivalent value (e.g. to set both to zero at a reference point), the assigned stepper motor should be stopped first, and the parameter **v_max** should be set to zero to hold the assigned stepper motor at rest before writing into the register **x_target** and **x_actual**.

8.5 v_target (IDX=%0100)

In modes RAMP_MODE and SOFT_MODE this register holds the current target velocity calculated internally by the ramp generator. In mode VELOCITY_MODE a target velocity can be written into this register. Then the associated stepper motor accelerates until it reaches the target velocity specified. In VELOCITY_MODE the velocity is changed according to the motion parameter limits if the register **v_target** is changed. In HOLD_MODE the register **v_target** is ignored.

8.6 v_actual (IDX=%0101)

This read-only register holds the current velocity of the associated stepper motor. Internally, the ramp generator of the TMC428 processes with 20 bits while only 12 bits can be read out as **v_actual**. So, an actual velocity of zero *read out* by the microcontroller means that the current velocity is in an interval between zero and one. Because of this, the actual velocity should not be used to detect a stop of a stepper motor. For stop detection there is a dedicated bit within the interrupt register, which can simply be read out by the micro processor or generate an interrupt. Writing zero to register **v_actual**, which is possible in HOLD_MODE only, immediately stops the associated stepper motor, because hidden bits are set to zero with each write access to the register **v_actual**. In HOLD_MODE only, this register is a read-write register. In HOLD_MODE, motion parameters are ignored and the microcontroller has the full control to generate a ramp. In that mode, the TMC428 only handles the microstepping and datagram generation for the associated stepper motor of the daisy chain.

8.7 a_max (IDX=%0110)

The absolute value of the maximum acceleration is defined by this register. It ranges from 0 to 2047. The unit of the acceleration is change of step frequency per time unit divided by 256. The scale of acceleration parameters (**a_max**, **a_actual**, **a_threshold**) is defined by the parameter **ramp_div** (see section 8.14, page 26 for details) and depends on the clock frequency of the TMC428. Setting **a_max** to zero during motion of the stepper motor results in the inability of the stepper motor to stop, because it cannot change its velocity.

8.7.1 a_max_lower_limit & a_max_upper_limit for ramp_div ≠ pulse_div

Under special conditions, the parameter **a_max** might have a lower limit (>1) and might an upper limit (<2047) concerning *deceleration* in RAMP_MODE and SOFT_MODE if the difference between **ramp_div** and **pulse_div** is more than one. This is because the deceleration ramp is internally limited to 2¹⁹ steps respectively micro steps, which is sufficient for most applications. The lower limit concerning the deceleration is given by

$$a_max_lower_limit = 2^{(ramp_div - pulse_div - 1)}$$

With **v_max** set to $2048 / \sqrt{2}$ (≈ 1448) or lower, the **a_max_lower_limit** is half of this value. If $ramp_div - pulse_div - 1 \leq 0$ the limit **a_max_lower_limit** is 1 and the parameter **a_max** may be set to down to 1 and of course to 0. On the other side, the upper limit of **a_max** is given by

$$a_max_upper_limit = 2^{(ramp_div - pulse_div + 12)} - 1$$

So, if $\text{ramp_div} - \text{pulse_div} + 1 \geq 0$ the **a_max_upper_limit** is > 2048 and the parameter **a_max** might be set to any value up to 2047.

Important Note: So, **a_max** can be set without restrictions within its range of 0 to 2047 for those combinations of **ramp_div** and **pulse_div** with $|\text{ramp_div} - \text{pulse_div}| \leq 1$.

The parameter **a_max** must not be set below **a_max_lower_limit** except **a_max** is set to 0. The condition $\text{a_max} \geq \text{a_max_lower_limit}$ as well as $\text{a_max} \leq \text{a_max_upper_limit}$ must be satisfied to reach any target position without oscillations. If that condition is not satisfied, oscillations around a target position may occur. For description of the parameters **ramp_div** and **pulse_div** see page 26.

So, **a_max_lower_limit** and **a_max_upper_limit** restrict the allowed range of **a_max** only for those cases where **ramp_div** is non-equal to **pulse_div** and differ more than one. These both limits of **a_max** concern the deceleration phase for **RAMP_MODE** and **SOFT_MODE** only. As long as $\text{ramp_div} \geq \text{pulse_div} - 1$ is valid, any value of **a_max** within its range (0,1, ..., 2047) is allowed and there exists a valid pair {**pmul**, **pdiv**} for each **a_max**. Qualitative verbalized, this is because the acceleration scaling determined by **ramp_div** is compatible with the step velocity scaling determined by **pulse_div**. In other words, large **ramp_div** stands for low acceleration where large **pulse_div** stands for low velocity and low acceleration is compatible with low speed and high speed as well, but high acceleration is more compatible with high speed.

Important Note: Changing at least one parameter out of the triple {**a_max**, **ramp_div**, **pulse_div**} requires re-calculation of the parameter pair {**pmul**, **pdiv**} to update the associated register. For description of the parameters **pmul** and **pdiv** see section 8.10, page 19.

8.8 a_actual (IDX=%0111)

The actual acceleration, which the TMC428 actually applies to a stepper motor, can be read out by the microcontroller from this read-only register for monitoring purposes. The actual acceleration is used to select scale factors for the coil currents. Internally, it is updated with each clock. The returned value **a_actual** is smoothed to avoid oscillations of the readout value. Thus, returned **a_actual** values should not be used directly for precise calculations.

8.9 is_agtat & is_aleat & is_v0 & a_threshold (IDX=%1000)

These parameters represent current scaling values I_s and are applied to the motor depending on the ramp phase: The parameter **is_agtat** is applied if the acceleration (a) is greater than (gt) a threshold acceleration (a_t). This is to increase current during acceleration phases. The parameter **is_aleat** is applied if the acceleration is lower than or equal to (le) the threshold acceleration. This is the nominal motor current. The third parameter **is_v0** is applied if the stepper motor is at rest, to save power, to keep it cool, and to avoid noise probably caused by chopper drivers. The parameter **a_threshold** is the threshold used to compare with the current acceleration to select the current scale factor. The three parameters **is_agtat**, **is_aleat**, and **is_v0** are bit vectors of three bit width. One of these is selected conditionally and assigned to an interim bit vector **i_scale**. The current scaling factor I_s is defined in Table 8-1.

| i_scale | | | I _s | | |
|---------|---|---|----------------|--------|---|
| 0 | 0 | 0 | 1 | = 100 | % |
| 0 | 0 | 1 | 1 / 8 | = 12.5 | % |
| 0 | 1 | 0 | 2 / 8 | = 25 | % |
| 0 | 1 | 1 | 3 / 8 | = 37.5 | % |
| 1 | 0 | 0 | 4 / 8 | = 50 | % |
| 1 | 0 | 1 | 5 / 8 | = 62.5 | % |
| 1 | 1 | 0 | 6 / 8 | = 75 | % |
| 1 | 1 | 1 | 7 / 8 | = 87.5 | % |

Table 8-1: Coil current scale factors

Important Notes: The maximum current scaling factor 1 is selected by **i_scale** = %000. This is the power-on default. The minimum current scaling factor 1/8 = 0.125 is selected by **i_scale** = %001. The current scaling factor I_s proportionally reduces the effective number of micro steps per full step. For example, with **i_scale** = %100 (= 4/8 = 50%) the number of effective micro steps per full step is halved.

One of the three scale factors **is_agtat**, **is_aleat**, and **is_v0** is selected according to Table 8-2. If the velocity is zero, the parameter **is_v0** is used for scaling. If the velocity is not zero, either **is_aleat** or **is_agtat** is used for scaling, depending on the absolute value of the acceleration and the acceleration threshold **a_threshold**.

| | | |
|--------------|---------------------------------|---------------------------|
| v = 0 | | $I_s := \text{is_v0}$ |
| v ≠ 0 | $a_{\text{threshold}} > 1023$ | $I_s := \text{is_aleat}$ |
| | $ a \leq a_{\text{threshold}}$ | $I_s := \text{is_aleat}$ |
| | $ a > a_{\text{threshold}}$ | $I_s := \text{is_agtat}$ |

Table 8-2: Current scale selection scheme

The automatic motion dependent current scale feature of the TMC428 is provided primarily for micro step operation. It may also be applied for full step or half step drivers, if those provide current control bits. For those drivers, one could initialize the micro step table with a constant function, square function or sine wave using the two most significant DAC bits.

The configuration bit **continuous_update** of the **stepper motor global parameter register** (Table 9-1, page 30) must be set to '1' to make sure that the coil current is scaled for v=0 if all motors are at rest.

The current is scaled for v=0 takes place delayed to avoid mechanical step lost due to oscillations of the motor after it has been stopped. The delay time is

$$t_{\text{isv0_delay}}[\text{s}] = 255 * (32 * 2^{\text{ramp_div}}) / \text{fCLK}[\text{Hz}].$$

Important Hints: Due to signed compare of **a_threshold** with **a_max**, a setting of **a_threshold** with a value greater than 1023 results in using **is_aleat** for current scaling if **a_max** is greater than 1023 during acceleration instead of using **is_agtat** for current scaling. For most applications, setting **is_aleat** and **is_agtat** to the same value and using a lower value for **is_v0** is the best choice.

8.10 pmul & pdiv (IDX=%1001)

The stepper motors are driven with a trapezoidal velocity profile, which may become triangular if the maximum velocity is not reached (see Figure 8-1, page 16). Depending on the difference between the target position **x_target** and the actual position **x_actual**, the ramp generator continuously calculates target velocities **v_target** for the pulse generator (see Figure 8-2, page 20). The pulse generator then generates (micro) step pulses taking into account the motion parameter limits (**v_min**, **v_max**, **a_max**). With a target velocity proportional to the difference of target position **x_target** and current position **x_actual**, the stepper motor approaches the target position. This also works, if the target position is changed during motion. The stepper motor moves to a target position until the difference between the target position **x_target** and the current position **x_actual** vanishes.

With the right proportionality factor **p**, target positions are quickly reached and without overshooting them. The proportionality factor primarily depends on the acceleration limit **a_max** and on the two clock divider parameters **pulse_div** and **ramp_div**. These two separate clock divider parameters— set to the same value for most applications —give an extremely wide dynamic range for acceleration and velocity. These two *separate* parameters allow reaching very high velocities with very low acceleration.

If the proportionality factor **p** is set too small, this results in a slow approach to the target position. If set too large, it causes overshooting and even oscillations around the target position. The calculation of the proportionality factor is simple:

The representation of the proportionality factor **p** by the two parameters **p_mul** and **p_div** is some kind of a fixed point representation. It is

$$p = p_mul / p_div$$

with

$$p_mul = \{128, 128+1, 128+2, 128+3, \dots, 128+127\}$$

and

$$p_div = \{2^3, 2^4, 2^5, \dots, 2^{14}, 2^{15}, 2^{16}\}.$$

Instead of direct storage of the parameters **p_mul** and **p_div**, the TMC428 stores two parameters called **pmul** and **pdiv**, with

$$p_mul = 128 + pmul \quad \text{and} \quad p_div = 2^{3+pdiv} = 2^{(3+pdiv)}$$

where

$$pmul = \{0, 1, 2, 3, \dots, 127\} \quad \text{and} \quad pdiv = \{0, 1, 2, 3, 4, 5, 6, 7, 8, 9, 10, 11, 12, 13\}.$$

The reason why **p_mul** ranges from 128 to 255 is, that **p** is divided by **p_div** which is a power of two ranging from 8 to 65536. So, values of **p** less than 128 can be achieved by increasing **p_div**.

Note: The parameters **pmul** and **pdiv** share a single address (IDX=%1001, see Table 7-2, page 15). The MSB of **p_mul** is fixed set to '1'. So, sending **pmul** internally sets **p_mul = 128 + pmul**. In other words, %10000000 = 128 is ORed as bit vector with the content of the register **pmul**.

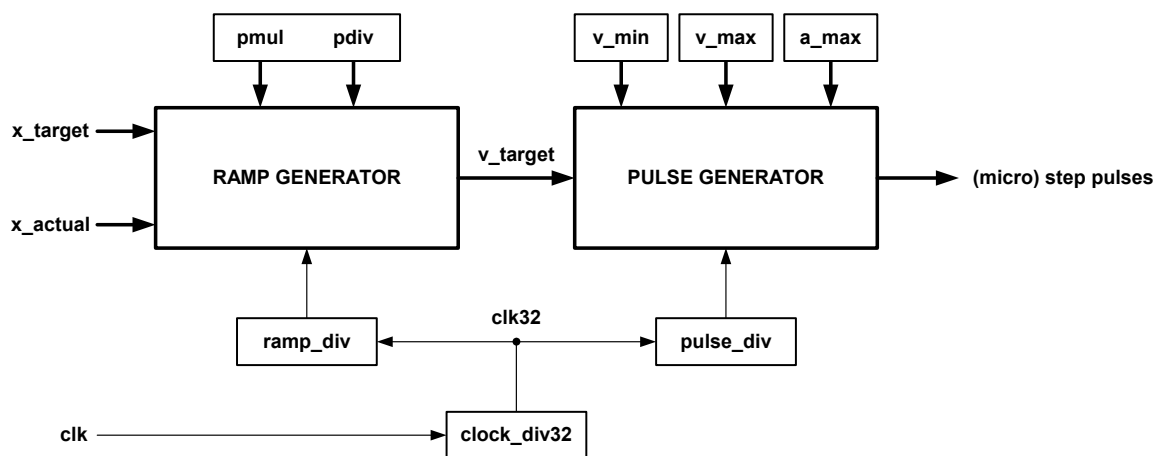

Figure 8-2: Ramp generator and pulse generator

The parameter **p** has to be calculated for a given acceleration. This calculation is not done by the TMC428 itself, because this task has to be done only once for a given acceleration limit. The acceleration limit is a stepper motor parameter, which is usually fixed in most applications. If the acceleration limit has to be changed nevertheless, the microcontroller could calculate on demand a pair of **p_mul** and **p_div** for each acceleration limit **a_max** and given **ramp_div** and **pulse_div**. Also, pre-calculated pairs of **p_mul** and **p_div** read from a table maybe sufficient.

8.11 Calculation of p_mul and p_div

The proportionality factor $p = p_mul / p_div$ depends on the acceleration limit a_max and frequency pre-divider parameters $ramp_div$ and $pulse_div$. So, a pair of p_mul / p_div has to be calculated once for each provided acceleration limit a_max . There may exist more than one valid pair of p_mul and p_div for a given a_max . To accelerate, the ramp generator accumulates the acceleration value to the actual velocity with each time step. Internally, the absolute value of the velocity is represented by $11+8 = 19$ bits, while only the most significant 11 bits and the sign are used as input for the step pulse generator. So, there are $2^{11} = 2048$ values possible to specify a velocity, ranging from 0 to 2047. The ramp generator accumulates a_max divided by $2^8 = 256$ at each time step to the velocity during acceleration phases. So, the acceleration from velocity = 0 to maximum velocity = 2047 spans over $2048 * 256 / a_max$ pulse generator clock pulses. Within that acceleration phase, the pulse generator generates $S = \frac{1}{2} * 2048 * 256 / a_max * T$ steps for the (micro) step unit. The parameter T is the clock divider ratio $T = 2^{ramp_div} / 2^{pulse_div} = 2^{ramp_div - pulse_div} = 2^{(ramp_div - pulse_div)}$. During acceleration, the velocity has to be increased until the velocity limit v_max is reached or deceleration is required to reach the target position exactly (see Figure 8-1). The TMC428 automatically decelerates, if required using the difference between current position and target position and the proportionality parameter p , which has to be $p = 2048 / S$. With this, one gets $p = 2048 / ((\frac{1}{2} * 2048 * 256 / a_max) * 2^{(ramp_div - pulse_div)})$. This expression can be simplified to

$$p = a_max / (128 * 2^{(ramp_div - pulse_div)}).$$

To avoid overshooting, the parameter p_mul should be made approximately 5% smaller than calculated. Alternatively, one can arrange p reduced by an amount of 5%. If the proportionality parameter p is too small, the target position will be reached slower, because the slow down ramp starts earlier. The target position is approached with minimal velocity v_min , whenever the internally calculated target velocity becomes less than v_min . With a good parameter p the minimal velocity v_min is reached a couple of steps before the target position. With parameter p set a little bit to large and small v_min overshooting of one step respectively one micro step may occur. Decrementation of the parameter $pmul$ avoids such one-step overshooting.

Note: Changing at least one parameter out of the triple $\{a_max, ramp_div, pulse_div\}$ requires re-calculation of the parameter pair $\{pmul, pdiv\}$ to update the associated register if necessary.

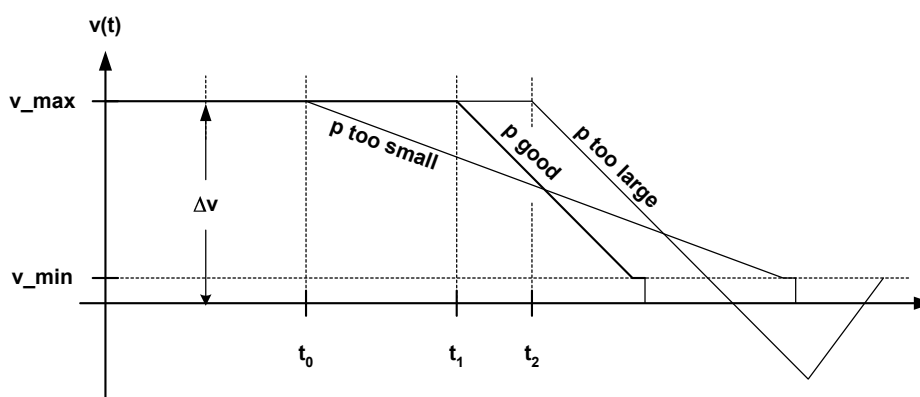

Figure 8-3: Proportionality parameter p and outline of velocity profile(s)

On first approach, to represent the parameter $p = p_mul / p_div = (128+pmul) / 2^{(3+pdiv)}$ one chooses a pair of $pmul$ and $pdiv$ that approximates p , with $pmul$ in range 0 ... 127 representing p_mul in range 128 ... 255 and $pdiv$ one out of $\{0, 1, 2, 3, 4, 5, 6, 7, 8, 9, 10, 11, 12, 13\}$ representing p_div one out of $\{8, 16, 32, 64, 128, 256, 512, 1024, 2048, 4096, 8192, 16384, 32786, 65536\}$. There are only $128 * 14 = 1792$ pairs of $(pmul, pdiv)$. So, one can simply try all possible pairs $(pmul, pdiv)$ with a program and choose a matching pair. To find a pair, one calculates

$$p = a_max / (128 * 2^{(ramp_div - pulse_div)})$$

and

$$p' = p_mul / p_div = (128 + pmul) / 2^{(3 + pdiv)}$$

and

$$q = p' / p$$

for each pair (**pmul** , **pdiv**) and select one of the pairs satisfying the condition $0.95 < q < 1.0$. So, the value **q** interpreted as a function **q(a_max, ramp_div, pulse_div, pmul, pdiv)** gives the quality criterion required. Although **q = 1.0** indicates that (**pmul** , **pdiv**) perfectly represents the desired **p** for a given **a_max**, this could cause overshooting because of finite numerical precision. In case of high resolution microstepping, overshooting of one micro step is negligible in most applications. To avoid overshooting, use **pmul-1** instead of the selected **pmul** or select a pair (**pmul**, **pdiv**) with **q = 0.95**. The first given source code example 'pmpdiv.c' showing programming in C language based on this brute force approach. Some conversions of the base present equations help to reduce the calculation effort drastically.

8.11.1 Optimized Calculation of p_mul and p_div

With the equations above, one can simplify the calculation of the parameters **pmul** and **pdiv** using the expression

$$pmul = p * 2^3 * 2^{pdiv} - 128$$

with

$$p = a_max / (128 * 2^{(pulse_div - ramp_div)}).$$

To avoid overshooting, use

$$p_reduced = p * (1 - p_reduction[\%])$$

with **p_reduction** approximately 5% instead of unreduced **p**. With this, one gets

$$pmul = p_reduced * 2^3 * 2^{pdiv} - 128 = 0.95 * p * 2^3 * 2^{pdiv} - 128.$$

With this, **pmul** becomes a function of the parameter **pdiv**. To find a valid pair {**pmul**, **pdiv**} one just has to choose that pair {**pmul**, **pdiv**} out of 14 pairs for **pdiv** = {0, 1, 2, 3, ..., 13} with **pmul** within the valid range $0 \leq pmul \leq 127$. An example 'pmpdiv.c' showing programming in C language can be found on page 53. This source code can directly be copied from the PDF datasheet file.

8.12 Ip & ref_conf & ramp_mode (rm) (IDX=%1010)

The bit called **Ip** (latched position) is a read only status bit. The configuration words **ref_conf** and **ramp_mode** are accessed via a common address, because these parameters normally are initialized only once. The configuration bits **ref_conf** select the behavior of the reference switches, while the two bits **ramp_mode (rm)** select one of the four possible stepping modes.

| ramp_mode | mode | function |
|-----------|----------------------|--|
| %00 | RAMP_MODE | default mode for positioning applications with trapezoidal ramp |
| %01 | SOFT_MODE | similar to RAMP_MODE, but with soft target position approaching |
| %10 | VELOCITY_MODE | mode for velocity control applications, change of velocities with linear ramps |
| %11 | HOLD_MODE | velocity is controlled by the microcontroller, motion parameter limits are ignored |

Table 8-3 – Outline of TMC428 motion modes

The mode called **RAMP_MODE** is provided as the default mode for positioning tasks, while the **VELOCITY_MODE** is for applications, where stepper motors have to be driven precisely with constant velocity. The **SOFT_MODE** is similar to the standard **RAMP_MODE** except that the target position is approached exponentially reduced velocity. This feature can be useful for applications where vibrations at the target position have to be minimized. The **HOLD_MODE** is provided for motion control applications, where the ramp generation is completely controlled by the microcontroller.

The TMC428 has three reference switch inputs REF1, REF2, REF3. Without additional hardware, three reference switches are available. These switches can be used as reference switches and can be used as automatic stop switches as well. Per default, one reference switch input is assigned individually to each stepper motor as a left reference switch (see Figure 9-3, page 32). The reference switch input REF3 can alternatively be assigned as the right reference switch of stepper motor number one (see Figure 9-4, page 32). In that configuration a *left and a right reference switch* is assigned to stepper motor one, a left reference switch is assigned to stepper motor two, and no reference switch is assigned to stepper motor three. The bit named **mot1r** in the stepper motor global parameter register ($rrs=1$ & $address=111111$) selects one of these configurations. With additional hardware, up to six reference switches— a left and a right one assigned to each stepper motor—are supported. The additional hardware is just a 74HC157, where three of four 2-to-1-multiplexers are used (see Figure 9-5, page 32). The feature of multiplexing is controlled by the bit named **refmux** in the stepper motor global parameter register ($rrs=1$ & $address=111111$).

A reference switch can be used as an automatic stop switch. The reference switch indicates the reference position within a given tolerance. The automatic stop function of the switches can be enabled or disabled. Also a reference tolerance range (see register **dx_ref_tolerance**, page 27) can be programmed, to allow motion within the reference switch active range during reference point search. When a reference switch is triggered, the actual position can be stored automatically. This allows precise determination of the reference point. This is initiated by writing a dummy value to register **x_latched** (see page 27). The read-only status bit **lp** (latch position waiting) then indicates that the next change of the selected reference switch will trigger latching the position **x_actual**. The **lp** bit is automatically reset after position latching.

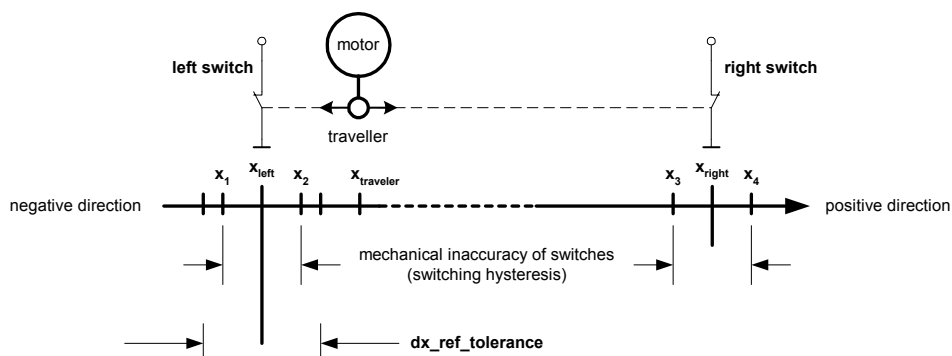

Figure 8-4: Left switch and right switch for reference search and automatic stop function

| ref_conf mnemonic | function |
|-------------------|--|
| DISABLE_STOP_L | 0 : Stops a motor if velocity is negative ($v_{actual} < 0$) and the left reference switch becomes active. 1 : Left reference switch is disabled as an automatic stop switch. |
| DISABLE_STOP_R | 0 : Stops a motor if velocity is positive ($v_{actual} > 0$) and the right reference switch becomes active. 1 : Right reference switch is disabled as an automatic stop switch. |
| SOFT_STOP | 0 : Stopping takes place immediately, motion parameter limits are ignored. 1 : Stopping takes place in consideration of motion parameter limits, stops with linear ramp. |
| REF_RnL | 0 : The left reference switch controls reference switch functions. 1 : The right (not left) reference switch controls reference switch functions. |
| lp | 0 : This is the power-on default of the lp (latched position waiting) bit. 1 : x_latched has been initialized by a write access to latch the position on a change of the reference switch. It is set to '0' after a position is latched. |

Table 8-4: Reference switch configuration bits (ref_conf)

Note: Definition of the reference switch by the configuration bit **REF_RnL** has no effect on the stop function of the reference switches if **DISABLE_STOP_L='0'** respectively **DISABLE_STOP_R='0'**. The bit **REF_RnL** (reference switch Right not Left) defines which switch is the reference switch: If set to '1', the right, else (set to '0') the left one is the reference switch.

The bits contained in **ref_conf** control the semantic and the actions of the reference/stop switch modes for interrupt generation as explained later. The stepper motor stops if the reference/stop switch, which corresponds to the actual driving direction, becomes active. The configuration bits named **DISABLE_STOP_L** respectively **DISABLE_STOP_R** disable these automatic stop functions. If the bit **SOFT_STOP** is set, motor stop forced by a reference switch is done within motion parameter limits while otherwise stopping is abruptly.

Hint: There is a functional difference between reference switches and stop switches. Reference switches are used to determine a reference position for a stepper motor. Stop switches are used for automatic stopping a motor when reaching a limit. The signals of switches are processed via the inputs named **REF1**, **REF2**, **REF3** might be used as automatic stop switches, reference switches, or both.

| 32 bit DATAGRAM sent from a µC to the TMC428 | | | | | | | | | | | | | | | | | | | | | | | | | | | | | | | | | | | |
|--|---|---------|---|---|---|---|---|---|---|----|------|---|---|---|----|----------|---|---|---|---|---|---|---|----|---|---|---|---|---|---|---|---|---|--|--|
| 3 | 2 | 1 | 0 | 9 | 8 | 7 | 6 | 5 | 4 | 3 | 2 | 1 | 0 | 9 | 8 | 7 | 6 | 5 | 4 | 3 | 2 | 1 | 0 | 9 | 8 | 7 | 6 | 5 | 4 | 3 | 2 | 1 | 0 | | |
| RRS | | ADDRESS | | | | | | | | RW | DATA | | | | | | | | | | | | | | | | | | | | | | | | |
| 0 | | smda | 1 | 0 | 1 | 0 | | | | | | | | | lp | ref_conf | | | | | | | | rm | | | | | | | | | | | |
| | | | | | | | | | | | | | | | | | | | | | | | | | | | | | | | | | | | %00 : RAMP, %01 : SOFT, %10 : VELOCITY, %11 : HOLD |

Table 8-5: lp & ref_conf & ramp_mode (rm) data bit positions

8.13 interrupt_mask & interrupt_flags (IDX=%1011)

The TMC428 provides one interrupt register of eight flags for each stepper motor. Interrupt bits are named **INT_<mnemonic>**. An interrupt bit can set back to '0' by writing '1' to it. Each interrupt bit can either be enabled ('1') or disabled ('0') individually by an associated interrupt mask bit named **MASK_<mnemonic>**. The interrupt flags are forced to '0' if the corresponding mask bit is disabled ('0'). The bit mapping of the interrupt mask bits and interrupt bits itself is diagrammed in Table 8-7 on page 25. The interrupt out **SDO_C / nINT** is set active low – where the interrupt status bit INT is set active high – when at least one interrupt flag of one motor becomes set. The interrupt mask enables or disables each interrupt mask individually. So, if the interrupt status is inactive, **nINT** is high ('1') and

switch changes from high to low and if the interrupt mask bit **MASK_STOP_LEFT_LOW** is set. The interrupt flag **INT_STOP_RIGHT_LOW** is similar to **INT_STOP_LEFT_LOW** but for the right reference switch. The **INT_STOP_LEFT_HIGH** indicates that the left reference switch input changes from low to high if the mask **MASK_STOP_LEFT_HIGH** is set. The **INT_STOP_RIGHT_HIGH** indicates it for the right reference switch if the mask **MASK_STOP_LEFT_HIGH** is set.

8.14 pulse_div & ramp_div & usrs (IDX=%1100)

The frequency of the external clock signal (see Figure 4-1, page 6, pin **CLK**) is divided by 32 (see Figure 8-2, page 20, block **clk_div32**). This clock drives two programmable clock dividers for the ramp generator and for the pulse generator. The pulse generator clock—defining the maximum step pulse rate—is determined by the parameter **pulse_div**. The pulse rate **R** is given by

$$R[\text{Hz}] = f_{\text{clk}}[\text{Hz}] * \text{velocity} / (2^{\text{pulse_div}} * 2048 * 32)$$

where **f_clk[Hz]** is the frequency of the external clock signal. The parameter **velocity** is in range 0 to 2047 and represents parameters **v_min**, **v_max** and absolute values of **v_target** and **v_actual**. So, the pulse generator of the TMC428 would generate one step pulse with each pulse generator clock pulse if the velocity could be set to 2048. The full step frequency **R_{FS}[Hz] = R[Hz] / 2^{usrs}**. The change **ΔR** in the pulse rate per time unit (pulse frequency change per second – the acceleration) is given by

$$\Delta R[\text{Hz/s}] = f_{\text{clk}}[\text{Hz}] * f_{\text{clk}}[\text{Hz}] * a_{\text{max}} / (2^{(\text{pulse_div} + \text{ramp_div} + 29)}).$$

The constant 29 within the exponent is because $2^{29} = 2^5 * 2^5 * 2^8 * 2^{11} = 32 * 32 * 256 * 2048$, where 32 comes from fixed clock pre-dividers, 256 comes from velocity accumulation clock pre-divider, and 2048 comes from velocity accumulation clock divider programmed by **a_max**. The parameter **a_max** is in range 0 to 2047. So, the parameter **ramp_div** scales the acceleration parameter **a_max**, where the parameter **pulse_div** scales the velocity parameters. $\Delta R_{\text{FS}}[\text{Hz}] = \Delta R[\text{Hz}] / 2^{\text{usrs}}$.

| usrs | | | [microsteps / full step] | significant DAC bits (controlling current amplitude) | comment |
|------|---|---|--------------------------|--|--|
| 0 | 0 | 0 | 1 | - | full step (constant current amplitude) |
| 0 | 0 | 1 | 2 | 5 (MSB) | |
| 0 | 1 | 0 | 4 | 5 (MSB), 4 | microstepping |
| 0 | 1 | 1 | 8 | 5 (MSB), 4, 3 | |
| 1 | 0 | 0 | 16 | 5 (MSB), 4, 3, 2 | |
| 1 | 0 | 1 | 32 | 5 (MSB), 4, 3, 2, 1 | |
| 1 | 1 | 0 | 64 | 5 (MSB), 4, 3, 2, 1, 0 (LSB) | |
| 1 | 1 | 1 | | | |

Table 8-8: micro step resolution selection (usrs) parameter

The angular velocity of a stepper motor can be calculated based on the full step frequency **R_{fs}[Hz]** for a given number of full steps per rotation. Similar, the angular acceleration of a stepper motor can be calculated based on the change of full step frequency per second **ΔR_{FS}[Hz]**. The three bit wide parameter **usrs** (micro (**μ**) step resolution selection, where **u** represents **μ**) determines the micro step resolution for its associated stepper motor according to Table 8-8. There is an individual set of 6 DAC bits provided for each of the two phases (coils) for current control to provide up to 64 micro steps per full step. Depending on the micro step resolution, a subset of 6 DAC bits is significant. Using full stepping, the current amplitude is constant for both phases (coils) of a stepper motor and the polarity of one phase (coil) changes with each full step. The micro step counters are initialized to 0 during power-on reset. With each micro step an associated counter accumulates the programmed micro step resolution value **usrs**.

Generally, the number of steps **S** during linear acceleration **a** to a velocity **v** is given by $S = \frac{1}{2} * v^2 / a$. With $v = R[\text{Hz}]$ and $a = \Delta R[\text{Hz/s}]$ one gets $S = \frac{1}{2} * \text{velocity}^2 / a_{\text{max}} * 2^{\text{ramp_div}} / 2^{\text{pulse_div}} / 2^3$. The number of full steps **S_{FS}** is $S_{\text{FS}} = S / 2^{\text{usrs}}$.

Important Hint: Changing **pulse_div** in VELOCITY_MODE or in HOLD_MODE might force an internal micro step (with micro step resolution defined by **usrs**) depending on the actual micro step position. This behavior can be observed especially when the motor is at rest in VELOCITY_MODE or in HOLD_MODE. In RAMP_MODE this does not occur. So, **pulse_div** should only be changed in RAMP_MODE.

8.15 dx_ref_tolerance (IDX=%1101)

The switches processed via the inputs REF1, REF2, REF3 can be used as stop switches for automatic motion limiting and as reference switches defining a reference position for the stepper motor. To allow the motor to drive near the reference point, it is possible to exclude a motion range of steps from the stop switch function. The parameter **dx_ref_tolerance** disables automatic stopping by a switch around the origin (see Figure 8-4, page 23). To use the **dx_ref_tolerance** fare from the origin, the actual position has to be suitable adapted, e.g. to use it for a left side reference switch. Additionally, the parameter **dx_ref_tolerance** affects interrupt conditions as described before (section 8.13, page 24).

8.16 x_latched (IDX=%1110)

This read-only register stores the actual position read from the register **x_actual** if the reference switch state changes. The reference switch is defined by the bit **REF_RnL** of the configuration register **Ip & ref_conf & ramp_mode**. Writing a dummy value to the (read-only) register **x_latched** initializes the position storage mechanism. Then the actual position is saved with the next rising edge or falling edge signal of the reference switch depending on the actual motion direction of the stepper motor. The actual position is latched when the switch defined as the reference switch by the **REF_RnL** bit changes (see Table 8-4: Reference switch configuration bits (ref_conf), page 23). The status bit **Ip** signals, if latching of a position is pending. An event at the reference switch associated to the actual motion direction takes effect only during motion (when **v_actual** ≠ 0).

8.17 Unused Address (IDX=%1111)

This register address (idx=%1111) within each stepper motor register block {smda=%00, %01, %10} is unused. Writing to this register has no effect. However, access should be avoided, because this address space may be used for future devices. Reading this register gives back the actual status bits and 24 data bits set to '0'.

9 Global Parameter Registers

The registers addressed by **RRS=0** with **SMDA=%11** are global parameter registers. To emphasize this difference, the **JDX** is used as index name instead of **IDX**.

9.1 datagram_low_word (JDX=%0000) & datagram_high_word (JDX=%0001)

The TMC428 stores datagrams sent back from the stepper motor driver chain with a total length of up to 48 bits. The register **datagram_low_word** holds the lower 24 bits of this 48 bits and the register **datagram_high_word** holds the higher 24 bits of the 48 bits. These registers together form a 48 bit shift register, where the data from pin **SDI_S** are shifted left into it with each datagram bit sent to the stepper motor driver chain via the signal **SDO_S**. A write to one of these read-only registers initializes them, to update their contents with the next datagram received from the drivers chain.

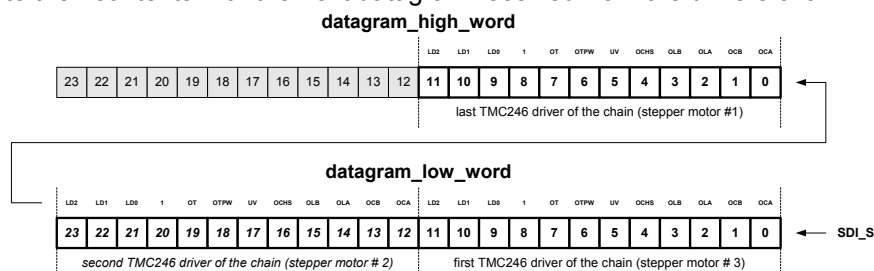

Figure 9-1: Example of status bit mapping for a chain of three TMC246 or TMC249

The **CDGW** (= **C**over **D**ata**G**ram **W**aiting, see section 9.3 on page 28) status bit is set to 1 until a datagram is received from the stepper motor driver chain. For read out of **datagram_low_word** and **datagram_high_word** the **CDGW** status bit is important to be able to detect when a datagram transfer has been completed after an initial write to one of the two registers. The fact that the **CDGW** is formed by logical OR between the cover datagram status and the status of the **datagram_low_word** and **datagram_high_word** causes no restriction concerning its usage. This is because a write to the **cover_datagram** register forces sending a datagram which results in an update of the **datagram_low_word** and **datagram_high_word** registers. On the other side, if the **cover_datagram** mechanism is not used, the **CDGW** status bit is exclusively available as the status signal of **datagram_low_word** and **datagram_high_word**.

9.2 cover_pos & cover_len (JDX=%0010)

The TMC428 provides direct sending of datagrams from the microcontroller to the stepper motor drivers. This may be necessary for initialization of different driver chips and useful for reconfiguration purposes. A datagram with up to 24 bits can be transferred to the stepper motor driver by covering one datagram sent to the driver chain. The parameter **cover_pos** defines the position of the first datagram bit to be covered by the **cover_datagram** (JDX=%0011) of length **cover_len**. In contrast to the datagram numbering order of bits, the position count for the cover datagram starts with 0. The **cover_datagram** bits indexed from **cover_len-1** to 0 cover the datagram sent to the drivers chain.

Important Note: *A step bit used to control stepper motor drivers must not be covered while a motor is running.*

This is because the coverage of a step bit would cause losing that associated step if the step bit is active. The TMC428 stores **cover_pos+1** instead of **cover_pos** due to internal requirements. So, one writes **cover_pos** but reads back **cover_pos+1**. The **cw** (= cover waiting) bit available by read out of this register. The **CDGW** status bit (see section 9.3) is the result of logical OR between **cw** and an internal signal that indicates the status of the stepper motor serial driver chain send register.

9.3 cover_datagram (JDX=%0011)

This register holds up to 24 bit of a cover datagram. A cover datagram covers the next datagram sent to the stepper motor driver chain. If no datagrams are sent to the drivers chain, the cover datagram is sent immediately if a cover datagram is written into this register. The status of the cover datagram is mapped to the status bits sent back with each datagram (see Table 6-4, page 12, **CDGW** status bit). This status bit is also available for readout of **cover_pos** & **cover_len** (JDX=%0010), where **CDGW** is the most significant data bit (23).

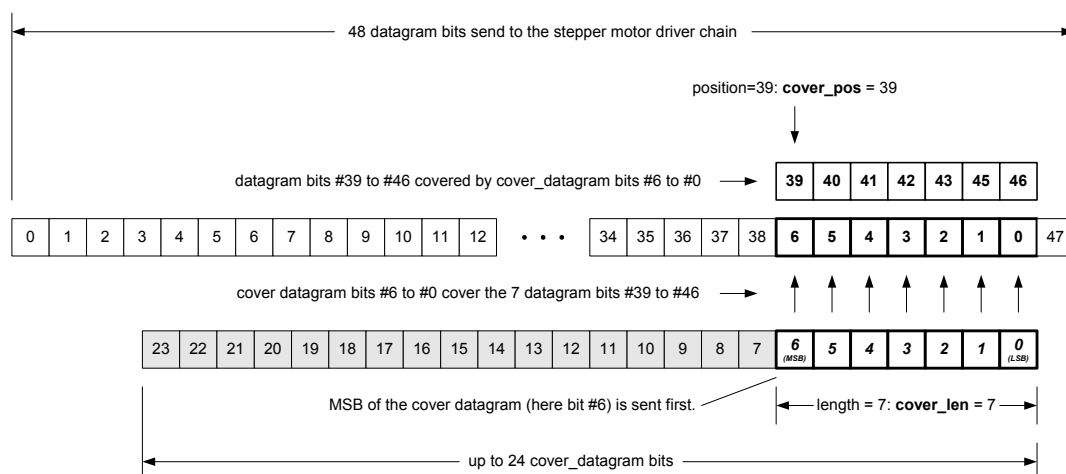

Figure 9-2: Cover datagram example

The **CDGW** (= Cover DataGram Waiting) status bit has to be checked before writing a new cover datagram into this register, to be sure that no cover datagram is waiting to be processed. The **CDGW** bit is set to 1 until the **cover_datagram** is sent. The **CDGW** status bit is also be used as a status bit for the **datagram_low_word** and **datagram_high_word** (see section 9.1 on page 27). An example for the cover datagram is given in Figure 9-2 on page 28. In that example 7 bits cover 7 bits of a 48 bit datagram from bit number 39 to bit number 46. A cover datagram with length=0 forces sending an unchanged datagram to the driver chain.

9.4 Unused Addresses (JDX={%0011, ..., %0111, %1001, ..., %1101})

There are unused addresses within the address range of the global parameter registers. Access to these addresses has no effect. However, access should be avoided, because this address space may be used for future devices.

9.5 power_down (JDX=%1000)

A write to the register address named **power_down** sets the TMC428 into the power down mode until it detects a falling edge at the pin **nSCS_C**. During power down, all internal clocks are stopped, all outputs remain stable, and all register contents are preserved.

9.6 Reference Switches I3 & r3 & I2 & r2 & I2 & r1 (JDX=%1110)

The current state of all reference switches— demultiplexed internally by the TMC428 if left and right reference switches are used —can be read from this read-only register. The bit named **continuous_update** of the **Stepper Motor Global Parameter Register (JDX=%1111)** is important for reading out of reference switches as explained below.

9.7 Stepper Motor Global Parameter Register (JDX=%1111)

This register holds different configuration bits for the stepper motor driver chain. The absolute address (RRS & ADDRESS) of the stepper motor global parameter register is %01111110 = \$7E (see Table 7-2, page 15, and Table 9-1, page 30). For the datagram configuration the number of stepper motor drivers is important. It is represented by the parameter **LSMD** (Last Stepper Motor Driver). The parameter **LSMD** has to be set to %00 for one stepper motor driver, %01 for two stepper motor drivers, and %10 for three stepper motor drivers (see Table 9-2).

clk2_div. With **clk2_div = 7** the clock frequency of **SCK_S** is at maximum. A value of **clk2_div = 7** is sufficient for the drivers TMC236 / TMC239 / TMC246 / TMC249.

Note: For most applications, a setting of **clk2_div = 7** is recommended.

For smooth motion even at high step frequencies the frequency **f_sck_s[Hz]** of the clock signal **SCK_S** should be as high as possible that is compatible with the used drivers. The frequency **f_sck_s[Hz]** of **SCK_S** does not become higher for **clk2_div < 7**, but the signal **SCK_S** becomes asymmetric with respect to its duty cycle. An asymmetric duty cycle may cause malfunction of stepper motor drivers, where stepper motor driver chips may work correctly in particular at low clock frequencies of **CLK**. So, the range of **clk2_div** is {7, 8, 9, . . ., 253, 254, 255}.

The default value after power-on reset is **clk2_div = 15**. The clock frequency **f_sck_s[Hz]** of **SCK_S** should be set as high as possible by choosing the parameter **clk2_div** in consideration of the data clock frequency limit defined by the slowest stepper motor driver chip of the daisy chain. If step frequencies reach the order of magnitude of the maximum datagram frequency—determined by the clock frequency of **SCK_S** and by the datagram length—the step frequencies may jitter, which is an inherent property of that serial communication. Up to which level variations of step frequencies are acceptable depends on the application. Using microstepping driver chips—as provided by TMC236 / TMC239 / TMC246 / TMC249 driver chips—avoids this problem.

The datagram frequency is $f_datagram[Hz] = f_sck_s[Hz] / (1 + datagram_length[bit] + 1)$. This formula is an approximation for the upper limit. For **clk2_div = 7** the processing of the NxM bit requires 1 SPI clock cycle, where the processing of the NxM bit requires 1.5 SPI clock cycles for **clk2_div > 7**. So, for a chain of three drivers with 12 bit datagram length each, the upper limit of the datagram frequency is $f_datagram[Hz] = f_sck_s[Hz] / (1 + 3*(12+1) + 1) = f_sck_s[Hz] / 41$.

The TMC428 sends datagrams to the stepper motor driver chain on demand only. No datagrams are sent if **continuous_update** is '0' during rest periods. This reduces the communication traffic. The multiplexed reference switch inputs are processed while datagrams are sent to the stepper motor driver chain only. If reference switches are configured to stop associated stepper motors automatically, the configuration bit **continuous_update** must be set to '1' to force periodic sending of datagrams to the stepper motor driver chain and to sample the reference switches periodically, if all stepper motors are at rest. With this, a stepper motor restarts if its associated reference switch becomes inactive. Without continuous update, a stepper motor stopped by a reference switch would stay at rest until a datagram is sent to the stepper motor driver chain, if its reference switch is inactive. Then, the relevant stepper motor can be moved into the direction opposite to the reference switch or it can be moved in both directions by disabling the automatic stop function. The continuous update datagram frequency is $f_cupd_s[Hz] = f_clk[Hz] * (1 / 2^{ramp_div_0} + 1 / 2^{ramp_div_1} + 1 / 2^{ramp_div_2}) / 32768$ where **ramp_div_0**, **ramp_div_1**, **ramp_div_2** are the **ramp_div** settings of the three stepper motors.

The bit **continuous_update** is also important for the automatic coil current scaling (see page 18). This bit must be set to '1' to be sure that the coil current is also scaled if all motors are at rest.

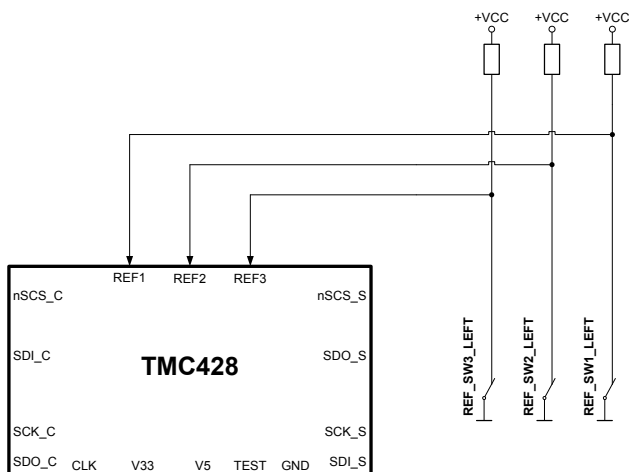

Figure 9-3: Reference switch configuration 'left-side-only' for mot1r=0 (and refmux=0)

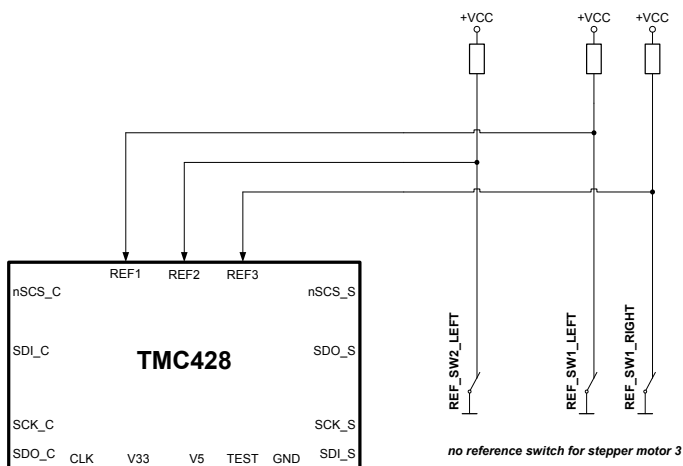

Figure 9-4: Reference switch configuration 'two-one-null' for mot1r=1 (and refmux=0)

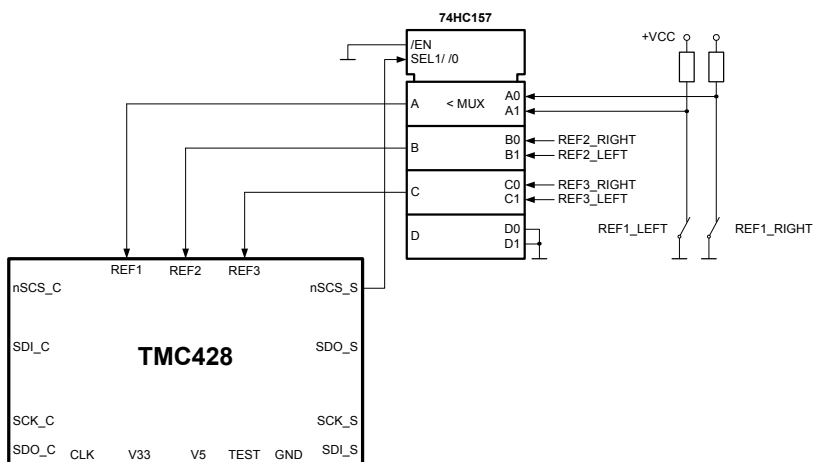

Figure 9-5: Reference switch multiplexing with 74HC157 (refmux=1)

| refmux | mot1r | motor 1 | | motor 2 | | motor 3 | |
|--------|-------|-------------|--------------|-------------|--------------|-------------|--------------|
| | | left switch | right switch | left switch | right switch | left switch | right switch |
| 0 | 0 | REF1 | % | REF2 | % | REF3 | % |
| 0 | 1 | REF1 | REF3 | REF2 | % | % | % |
| 1 | 0 | REF1_LEFT | REF1_RIGHT | REF2_LEFT | REF2_RIGHT | REF3_LEFT | REF3_RIGHT |
| 1 | 1 | REF1_LEFT | REF1_RIGHT | REF2_LEFT | REF2_RIGHT | REF3_LEFT | REF3_RIGHT |

Table 9-3: Association of reference inputs depending on configuration bits refmux & mot1r

If **continuous_update** is '1', internal reference switch bits are updated periodically, even if all stepper motors are at rest. Additionally, the chip select signal **nSCS_S** for the stepper motor driver chain is also the control signal for a multiplexer in case of using the reference switch multiplexing option (see Figure 9-5). So, the **continuous_update** must be set to '1' if automatic stop by reference switches is enabled, if six multiplexed reference switches are used, and to get the states of reference switches while all stepper motors are at rest.

The bit named **refmux** must be set to '1' to enable reference switch multiplexing (see Figure 9-5). For the two variants TMC428-PI24 and TMC428-DI20, the reference switch multiplexing also works for **csCommonIndividual**= '1' using three separate driver selection signals (**nSCS_S**, **nSCS2**, **nSCS3**) if the signal **nSCS_S** is connected to the multiplexer 74HC157 according to Figure 9-8.

If reference switch multiplexing is enabled, **mot1r** is ignored. With **refmux** set to '0', the association of the reference switch inputs **REF1**, **REF2**, **REF3** depends on the setting of the configuration bit **mot1r**. The power-on default value of **mot1r** is '0'. With that default value, **REF1** is associated to the left reference switch of stepper motor #1, **REF2** is associated to the left reference switch of stepper motor #2, and **REF3** is associated to the left reference switch of stepper motor #3.

If **mot1r** is set to '1' the input **REF1** is also associated with the left reference switch of stepper motor #1. **REF2** is also associated to the left reference switch of stepper motor #2. But, the input **REF3** is associated to the *right reference switch* of stepper motor #1 and no reference switch input is associated to stepper motor number #3 (see Figure 9-4). After power-on-reset, per default **refmux=0** and **mot1r=0** selects the single reference switch configuration outlined in Figure 9-3, where each reference switch input (**REF1**, **REF2**, **REF3**) is assigned individually to one each stepper motor as the left reference switch.

9.8 Triple Switch Configuration

The programmable tolerance range around the reference switch position is useful for a triple switch configuration, as outlined in Figure 9-6. In that configuration two switches are used as automatic stop switches, and one additional switch is used as the reference switch between the left stop switch and the right stop switch. The left stop switch and the reference switch are wired or. After successful reference search, programming a tolerance range into the register **dx_ref_tolerance** allows to disable automatic stop within the range of the reference switch only.

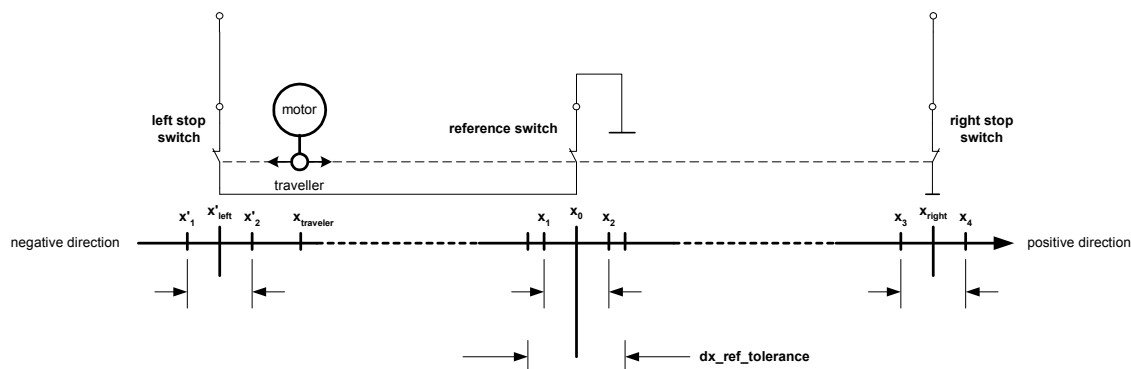

Figure 9-6: Triple switch configuration 'left stop switch – reference switch – right stop switch'

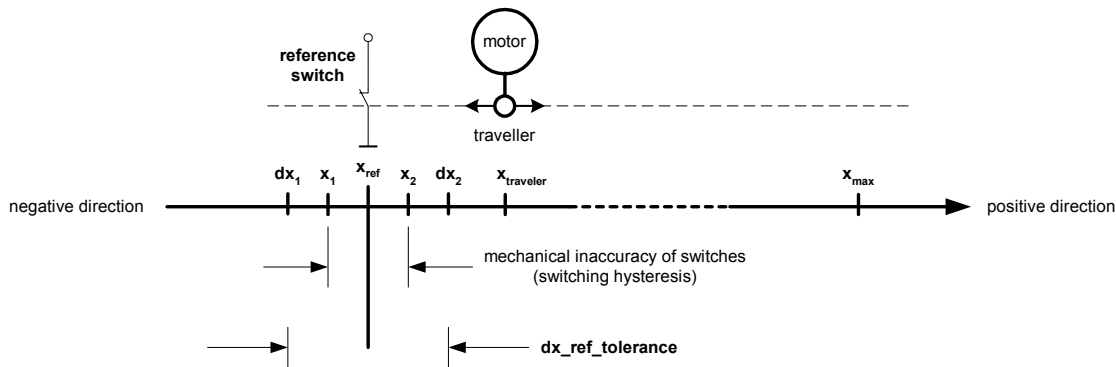

Figure 9-7: Reference search

9.9 Reference Search

The goal of the reference search is to determine the position x_{ref} of a reference switch (see Figure 9-7). Due to mechanical inaccuracy of switches, the reference switch is active within a range $x_1 < x_{ref} < x_2$, where x_1 and x_2 may vary. If the traveler is within the range $x_1 < x_{traveler} < x_2$ before reference search, it is necessary to go outside this range, because the associated reference switch is active. A dummy write access to $x_{latched}$ initializes the position latch register. Then, with the traveler within the range $x_2 < x_{traveler} < x_{max}$ and the initialized register $x_{latched}$, the position x_2 can simply be determined by motion with a target position x_{target} set to $-x_{max}$. When reaching the position x_2 , this position is latched automatically. With stop switch enabled, the stepper motor automatically stops if the position x_2 is reached. Then, the $dx_{ref_tolerance}$ has to be set, so that motion within the active reference switch range $x_1 < x_{ref} < x_2$ is allowed and to move the traveler to a position $x_{traveler} < x_1$ if desired. Then the register $x_{latched}$ has to be initialized again to latch the position x_1 by a motion to a target position $x_{traveler} < x_1$. When the positions x_1 and x_2 are determined the reference position $x_{ref} = (x_1 + x_2) / 2$ can be set. Finally, one should move to the target position $x_{target} = x_{ref}$ and set $x_{target} := 0$ and $x_{actual} := 0$ when reached.

9.10 Simultaneous Start of up to Three Stepper Motors

Starting stepper motors simultaneously can be achieved by sending successive datagrams starting the stepper motors. If the delay between those datagrams is of the magnitude of some microseconds, the stepper motors can be considered as started simultaneously. Feeding the reference switch signals through or gates (see Figure 9-8) allows exact simultaneous start of the stepper motors under software control.

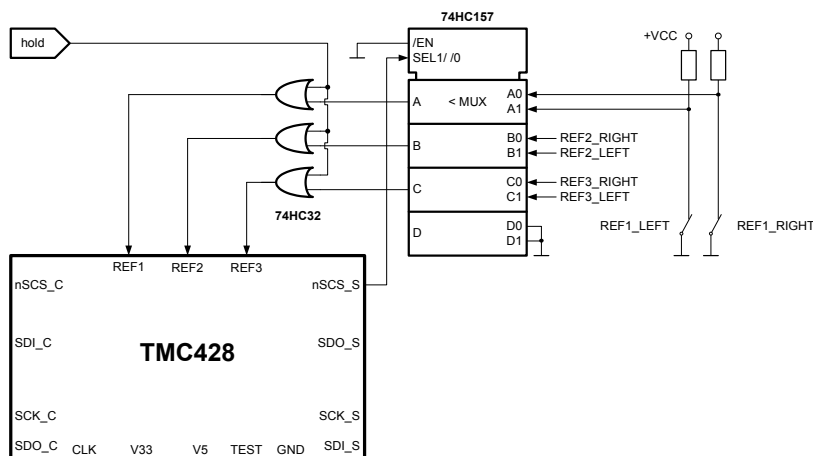

Figure 9-8: Reference switch gateing for exact simultaneous stepper motor start

11 Stepper Motor Driver Datagram Configuration

A number of control signals is required to drive 2-phase stepper motors. The serial driver interface forms the link between the TMC428 and the stepper motor driver chain. The stepper motor driver datagram configuration simply defines the order of the control signals serially sent from TMC428 to the stepper motor driver chain. To define the serial order of the control signals, so called primary signal codes have to be written into the stepper motor driver datagram configuration area of the on-chip configuration RAM of the TMC428.

Which control signals are required in a given application, depends on the choice of stepping mode– full step, half step, micro step –and on additional options depending on the stepper motor driver chips used. So, the TMC428 primarily provides a full set of control signals individually for each of the up to three stepper 2-phase stepper motors respectively stepper motor driver chips of the daisy chain. Mnemonics for primary signal codes are given in Table 11-1. Names of these signals may differ to the signal names of the used stepper motor drivers. Figure 11-1 on page 36 outlines the principle of connecting the control signals– internally provided by the TMC428 as parallel signals –with the signals used to control the digital part of a stepper motor driver.

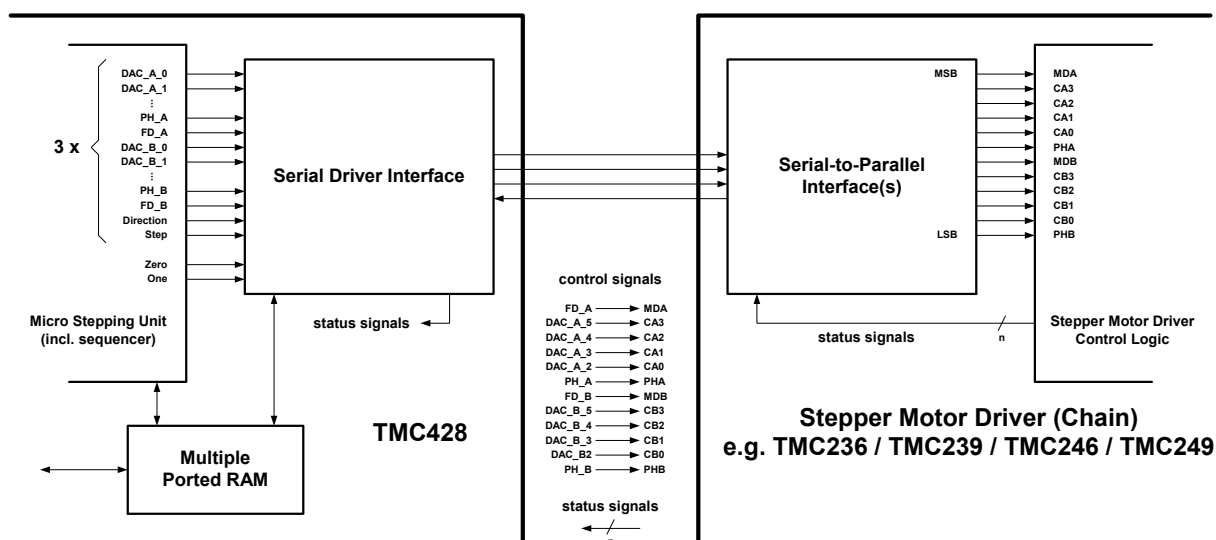

Figure 11-1: Serially transmitted control and status signals between TMC428 and driver chain

| MNEMONIC | PRIMARY SIGNAL CODE | | FUNCTION | |
|----------|---------------------|--------|----------------------|--------|
| | hex | bin | | |
| DAC_A_0 | \$00 | %00000 | DAC A, bit 0 (LSB) | COIL A |
| DAC_A_1 | \$01 | %00001 | DAC A, bit 1 | |
| DAC_A_2 | \$02 | %00010 | DAC A, bit 2 | |
| DAC_A_3 | \$03 | %00011 | DAC A, bit 3 | |
| DAC_A_4 | \$04 | %00100 | DAC A, bit 4 | |
| DAC_A_5 | \$05 | %00101 | DAC A, bit 5 (MSB) | |
| PH_A | \$06 | %00110 | phase polarity bit A | COIL B |
| FD_A | \$07 | %00111 | fast decay bit A | |
| DAC_B_0 | \$08 | %01000 | DAC B, bit 0 (LSB) | |
| DAC_B_1 | \$09 | %01001 | DAC B, bit 1 | |
| DAC_B_2 | \$0A | %01010 | DAC B, bit 2 | |
| DAC_B_3 | \$0B | %01011 | DAC B, bit 3 | |
| DAC_B_4 | \$0C | %01100 | DAC B, bit 4 | COIL B |
| DAC_B_5 | \$0D | %01101 | DAC B, bit 5 (MSB) | |
| PH_B | \$0E | %01110 | phase polarity bit B | |
| FD_B | \$0F | %01111 | fast decay bit B | |
| Zero | \$10 | %10000 | constant '0' | |

| | | | |
|--|---------------|---------------|--|
| One | \$11 | %10001 | constant '1' |
| Direction | \$12 | %10010 | 0 : up / 1 : down resp. counter clockwise / clockwise |
| Step | \$13 | %10011 | step bit for step/direction control of drivers |
| UNUSED (these codes might be used for future devices) | \$14 | %10100 | '1' for TMC428-I, TMC428-A, TMC428-PI24, TMC428-DI20 |
| | \$15 | %10101 | |
| | \$16 | %10110 | |
| | \$17 | %10111 | |
| | \$18 | %11000 | |
| | \$19 | %11001 | |
| | \$1° | %11010 | |
| | \$1B | %11011 | |
| | \$1C | %11100 | |
| | \$1D | %11101 | |
| \$1E | %11110 | | |
| \$1F | %11111 | | |

Table 11-1: Primary signal codes

The control signals for each of the two coils of a 2-phase stepper motor are 6 bits for the DAC controlling the current of a coil, a phase polarity bit, and a fast decay bit for those stepper motor driver chips with a fast decay feature for the coil current. These signals are available individually for each coil (COIL A and COIL B). Constant configuration bits named Zero and One are provided. Additionally, step and direction bits are available. One unique 5 bit code word– named primary signal code –is assigned to each primary control signal (see Table 11-1).

The micro step unit (including sequencer) provides the full set of control signals for three stepper motor driver chips. A subset of these control signals is selected by the stepper motor driver datagram configuration, which is stored within the first 32 addresses representing 64 values of the on-chip RAM (see Table 10-1, page 35). The stepper motor drivers are organized in a daisy chain. So the addressing of the stepper motor driver chips within the daisy chain is by its position.

As mentioned before, the TMC428 sends datagrams to the stepper motor driver chain on demand. To guarantee the integrity of each datagram sent to the stepper motor driver chain, the status of all primary control signals is buffered internally before sending. Afterwards, the transmission starts with selection of the buffered primary control signals of the first motor (**smda=%00**) by reading the first primary signal code word (even data word at on-chip RAM address %00000) from on-chip configuration RAM area. The primary signal codes select the primary signals provided for the first stepper motor. The first stepper motor is addressed until the **NxM** (next motor) bit is read from on-chip configuration RAM. The stepper motor driver address is incremented with each **NxM='1'** as long as the current stepper motor driver address is below the value set by the parameter **LSMD** (last stepper motor driver). If the stepper motor driver address is equivalent to the **LSMD** parameter, a **NxM='1'** indicates the completion of the transmission. With that, the stepper motor driver address counter of the serial interface is reinitialized to %00 and the unit waits for the next transmission request.

So, the order of primary signal codes in the on-chip RAM configuration area determines the order of datagram bits for the stepper motor driver chain, whereas the prefixed NxM bit determines the stepper motor driver positions. If no NxM bit with a value of '1' is stored within the on-chip RAM, the TMC428 will send endlessly. So, the on-chip RAM has to be configured first. After power-on reset, the registers of the TMC428 are initialized in a way, that no transmission of datagrams to the motor driver chain is required. Access to on-chip RAM is always possible, also during transmission of datagrams to the driver chain.

11.1 Initialization of on-chip-RAM by μ C after power-on

All registers are initialized by the automatic power-on reset. The registers are initialized, and the stepper motors are at rest. The on-chip RAM is not initialized by the power-on reset. Writing to registers may involve action of the stepper motor units initiated by the TMC428 resulting in sending datagrams to the stepper motor driver chain. Those datagrams have a random power-on configuration of the on-chip-RAM. So, before trying to move a motor, the on-chip RAM must be initialized first.

11.2 An Example of a Stepper Motor Driver Datagram Configuration

The following example demonstrates, how to configure the datagram and shows what has to be stored within the on-chip RAM to represent the desired configuration. That example refers to a driver chain of three TRINAMIC stepper motor drivers of type TMC236, TMC239, TMC246, TMC249. From the TMC428 datagram configuration point of view, there is no difference between these drivers. All these drivers have a serial interface of 12 bits length. The configuration is as follows. For the first and the second stepper motor driver of the chain the fast decay control bit (FD_A, FD_B) is fixed to '0'. For the third driver the fast decay control bit are used. The corresponding content of the configuration on-chip RAM is outlined in Table 11-2. The sequence to be sent to the TMC428 for this configuration is outlined in Table 11-3.

Hint: The stepper motor driver datagram configuration can be accessed at any time without conflict, e.g. to be changed between a configuration using fast decay versus a configuration where fast decay is disabled.

| position within datagram | driver | NxM bit | TMC428 signal code | RAM address | RAM data | TMC428 mnemonic of primary signal | | TMC23x / TMC24x Bit Name |
|--------------------------|---------------------|---------|--------------------|-------------|----------|-----------------------------------|---|--------------------------|
| 0 | driver#1 (SMDA=%00) | 0 | \$10 | \$00 | \$10 | Zero | → | MDA |
| 1 | | 0 | \$05 | \$01 | \$05 | DAC_A_5 | → | CA3 |
| 2 | | 0 | \$04 | \$02 | \$04 | DAC_A_4 | → | CA2 |
| 3 | | 0 | \$03 | \$03 | \$03 | DAC_A_3 | → | CA1 |
| 4 | | 0 | \$02 | \$04 | \$02 | DAC_A_2 | → | CA0 |
| 5 | | 0 | \$06 | \$05 | \$06 | PH_A | → | PHA |
| 6 | | 0 | \$10 | \$06 | \$10 | Zero | → | MDB |
| 7 | | 0 | \$0D | \$07 | \$0D | DAC_B_5 | → | CB3 |
| 8 | | 0 | \$0C | \$08 | \$0C | DAC_B_4 | → | CB2 |
| 9 | | 0 | \$0B | \$09 | \$0B | DAC_B_3 | → | CB1 |
| 10 | | 0 | \$0A | \$0A | \$0A | DAC_B_2 | → | CB0 |
| 11 | | 1 | \$0E | \$0B | \$2E | PH_B | → | PHB |
| 12 | driver#2 (SMDA=%01) | 0 | \$10 | \$0C | \$10 | Zero | → | MDA |
| 13 | | 0 | \$05 | \$0D | \$05 | DAC_A_5 | → | CA3 |
| 14 | | 0 | \$04 | \$0E | \$04 | DAC_A_4 | → | CA2 |
| 15 | | 0 | \$03 | \$0F | \$03 | DAC_A_3 | → | CA1 |
| 16 | | 0 | \$02 | \$10 | \$02 | DAC_A_2 | → | CA0 |
| 17 | | 0 | \$06 | \$11 | \$06 | PH_A | → | PHA |
| 18 | | 0 | \$10 | \$12 | \$10 | Zero | → | MDB |
| 19 | | 0 | \$0D | \$13 | \$0D | DAC_B_5 | → | CB3 |
| 20 | | 0 | \$0C | \$14 | \$0C | DAC_B_4 | → | CB2 |
| 21 | | 0 | \$0B | \$15 | \$0B | DAC_B_3 | → | CB1 |
| 22 | | 0 | \$0A | \$16 | \$0A | DAC_B_2 | → | CB0 |
| 23 | | 1 | \$0E | \$17 | \$2E | PH_B | → | PHB |
| 24 | driver#3 (SMDA=%10) | 0 | \$07 | \$18 | \$07 | FD_A | → | MDA |
| 25 | | 0 | \$05 | \$19 | \$05 | DAC_A_5 | → | CA3 |
| 26 | | 0 | \$04 | \$1° | \$04 | DAC_A_4 | → | CA2 |
| 27 | | 0 | \$03 | \$1B | \$03 | DAC_A_3 | → | CA1 |
| 28 | | 0 | \$02 | \$1C | \$02 | DAC_A_2 | → | CA0 |
| 29 | | 0 | \$06 | \$1D | \$06 | PH_A | → | PHA |
| 30 | | 0 | \$0F | \$1E | \$0F | FD_B | → | MDB |
| 31 | | 0 | \$0D | \$1F | \$0D | DAC_B_5 | → | CB3 |
| 32 | | 0 | \$0C | \$20 | \$0C | DAC_B_4 | → | CB2 |
| 33 | | 0 | \$0B | \$21 | \$0B | DAC_B_3 | → | CB1 |
| 34 | | 0 | \$0A | \$22 | \$0A | DAC_B_2 | → | CB0 |
| 35 | | 1 | \$0E | \$23 | \$2E | PH_B | → | PHB |

With LSMD = %10 the (third) NxM bit at address \$23 (position 35) finishes the datagram transmission

Table 11-2: Datagram example and RAM contents for three stepper motor driver chain

| | | |
|-------------------------------|---|----------------------|
| binary datagram specification | : | hexadecimal datagram |
| %10000000-----000101-010000 | : | \$80000510 |
| %10000010-----000011-000100 | : | \$82000304 |
| %10000100-----000110-000010 | : | \$84000602 |
| %10000110-----001101-010000 | : | \$86000D10 |
| %10001000-----001011-001100 | : | \$88000B0C |
| %10001010-----101110-001010 | : | \$8°002E0A |
| %10001100-----000101-010000 | : | \$8c000510 |
| %10001110-----000011-000100 | : | \$8e000304 |
| %10010000-----000110-000010 | : | \$90000602 |
| %10010010-----001101-010000 | : | \$92000D10 |
| %10010100-----001011-001100 | : | \$94000B0C |
| %10010110-----101110-001010 | : | \$96002E0A |
| %10011000-----000101-000111 | : | \$98000507 |
| %10011010-----000011-000100 | : | \$9°000304 |
| %10011100-----000110-000010 | : | \$9c000602 |
| %10011110-----001101-001111 | : | \$9e000D0F |
| %10100000-----001011-001100 | : | \$a0000B0C |
| %10100010-----101110-001010 | : | \$a2002E0A |

Table 11-3: Configuration datagram sequence for the example (with '-' (don't cares))

12 Initialization of the Micro Step Look-Up-Table

The TMC428 provides a look-up-table (LUT) of 64 values of 6 bit for micro stepping. The micro step LUT can be adapted by storing an arbitrary quarter period of a periodic function to match individual stepper motor characteristics. It is common to use one period of a sine wave function for micro stepping. With that function, the current of one phase is driven with the sine function whereas the other phase is driven with the cosine function.

To initialize the LUT for micro stepping one simply has to load a quarter sine wave period into the micro step LUT. Two successive values of the sine wave function are included in one datagram similar to the primary signal code words for the stepper motor driver chain configuration. The TMC428 automatically expands the quarter sine wave period to a full sine and cosine function. The necessary data values $y(i)$ to represent a $\frac{1}{4}$ sine wave period for the micro step LUT are defined by

$$y(i) = \text{int}[\frac{1}{2} + 64 * \sin(\frac{1}{4} * 2 * \pi * i / 64)] \quad \text{with } i = \{ 0, 1, 2, 3, \dots, 60, 61, 62, 63 \},$$

where the conditional replacement $y(i) := 63$ for $y(i) > 63$ has to be done. The last five values (which are calculated to be 64) have to be replaced by 63. With this replacement one finally gets $y(i) = \{ 0, 2, 3, 5, 6, 8, 9, 11, 12, 14, 16, 17, 19, 20, 22, 23, 24, 26, 27, 29, 30, 32, 33, 34, 36, 37, 38, 39, 41, 42, 43, 44, 45, 46, 47, 48, 49, 50, 51, 52, 53, 54, 55, 56, 56, 57, 58, 59, 59, 60, 60, 61, 61, 62, 62, 62, 63, 63, 63, 63, 63, 63 \}$.

| 32 bit DATAGRAM sent from a µC to the TMC428 via pin SDI_C | | | | | | | | | | | | | | | | | | | | | | | | | | | | | | | |
|--|---------|---|---|---|---|---|---|---|---|---|---|---|---|---|------|---|---|---|---|---|---|---|---|---|---|---|---|---|---|---|---|
| 3 | 0 | 9 | 8 | 7 | 6 | 5 | 4 | 3 | 2 | 1 | 0 | 9 | 8 | 7 | 6 | 5 | 4 | 3 | 2 | 1 | 0 | 9 | 8 | 7 | 6 | 5 | 4 | 3 | 2 | 1 | 0 |
| | ADDRESS | | | | | | | | | | | | | | DATA | | | | | | | | | | | | | | | | |
| 1 | ADDRESS | | | | | | | | | | | | | | DATA | | | | | | | | | | | | | | | | |
| | ADDRESS | | | | | | | | | | | | | | DATA | | | | | | | | | | | | | | | | |
| 1 | ADDRESS | | | | | | | | | | | | | | DATA | | | | | | | | | | | | | | | | |
| | ADDRESS | | | | | | | | | | | | | | DATA | | | | | | | | | | | | | | | | |
| | ADDRESS | | | | | | | | | | | | | | DATA | | | | | | | | | | | | | | | | |
| 1 | 1 | 0 | 0 | 0 | 0 | 0 | 0 | 0 | 0 | 0 | 0 | 1 | 0 | 0 | 0 | 0 | 0 | 1 | 0 | 0 | 0 | 0 | 0 | 0 | 0 | 0 | 0 | 0 | 0 | 0 | 0 |
| 1 | 1 | 0 | 0 | 0 | 0 | 0 | 1 | 0 | 0 | 0 | 0 | 1 | 0 | 1 | 0 | 1 | 0 | 1 | 0 | 3 | 0 | 0 | 0 | 0 | 0 | 1 | 1 | 0 | 0 | 0 | 0 |
| 1 | 1 | 0 | 0 | 0 | 1 | 0 | 0 | 0 | 0 | 0 | 0 | 0 | 0 | 0 | 0 | 1 | 0 | 0 | 0 | 6 | 0 | 0 | 0 | 1 | 1 | 0 | 0 | 0 | 0 | 0 | 0 |

| | | | | | | | | | | | | | | | | | | | |
|---|---|---|---|---|--|----|---|---|---|---|---|---|----|---|---|---|---|---|---|
| 0 | 0 | 0 | 1 | 1 | | 11 | 0 | 0 | 1 | 0 | 1 | 1 | 9 | 0 | 0 | 1 | 0 | 0 | 1 |
| 0 | 0 | 1 | 0 | 0 | | 14 | 0 | 0 | 1 | 1 | 1 | 0 | 12 | 0 | 0 | 1 | 1 | 0 | 0 |
| | | | | | | | | | | | | | | | | | | | |
| | | | | | | | | | | | | | | | | | | | |
| ⋮ | ⋮ | ⋮ | ⋮ | ⋮ | | | ⋮ | ⋮ | ⋮ | ⋮ | ⋮ | ⋮ | | ⋮ | ⋮ | ⋮ | ⋮ | ⋮ | |
| | | | | | | | | | | | | | | | | | | | |
| | | | | | | | | | | | | | | | | | | | |
| 1 | 1 | 0 | 1 | 1 | | 62 | 1 | 1 | 1 | 1 | 1 | 0 | 62 | 1 | 1 | 1 | 1 | 1 | 0 |
| 1 | 1 | 1 | 0 | 0 | | 63 | 1 | 1 | 1 | 1 | 1 | 1 | 63 | 1 | 1 | 1 | 1 | 1 | 1 |
| 1 | 1 | 1 | 0 | 1 | | 63 | 1 | 1 | 1 | 1 | 1 | 1 | 63 | 1 | 1 | 1 | 1 | 1 | 1 |
| 1 | 1 | 1 | 1 | 0 | | 63 | 1 | 1 | 1 | 1 | 1 | 1 | 63 | 1 | 1 | 1 | 1 | 1 | 1 |
| 1 | 1 | 1 | 1 | 1 | | 63 | 1 | 1 | 1 | 1 | 1 | 1 | 63 | 1 | 1 | 1 | 1 | 1 | 1 |

Table 12-1: Scheme of $\frac{1}{4}$ sine wave period with 6 bit resolution and 64 (32 x 2) values

These 64 values represent a quarter sine period in the interval $[0 \dots \pi/4[$ which is expanded automatically by the TMC428 to a full sine cosine period (see section 12.1, page 41). The table is sent to the on-chip RAM of the TMC428 by 32 datagrams:

% binary representation of the datagram : decimal represented pair of values : \$ hexadecimal representation
(separated by & character)

```

% 11 00000 0 00000000 00 000010 00 000000 : 2 & 0 : $C0000200
% 11 00001 0 00000000 00 000101 00 000011 : 5 & 3 : $C2000503
% 11 00010 0 00000000 00 001000 00 000110 : 8 & 6 : $C4000806
% 11 00011 0 00000000 00 001011 00 001001 : 11 & 9 : $C6000B09
% 11 00100 0 00000000 00 001110 00 001100 : 14 & 12 : $C8000E0C
% 11 00101 0 00000000 00 010001 00 010000 : 17 & 16 : $CA001110
% 11 00110 0 00000000 00 010100 00 010011 : 20 & 19 : $CC001413
% 11 00111 0 00000000 00 010111 00 010110 : 23 & 22 : $CE001716

% 11 01000 0 00000000 00 011010 00 011000 : 26 & 24 : $D0001A18
% 11 01001 0 00000000 00 011101 00 011011 : 29 & 27 : $D2001D1B
% 11 01010 0 00000000 00 100000 00 011110 : 32 & 30 : $D400201E
% 11 01011 0 00000000 00 100010 00 100001 : 34 & 33 : $D6002221
% 11 01100 0 00000000 00 100101 00 100100 : 37 & 36 : $D8002524
% 11 01101 0 00000000 00 100111 00 100110 : 39 & 38 : $DA002726
% 11 01110 0 00000000 00 101010 00 101001 : 42 & 41 : $DC002A29
% 11 01111 0 00000000 00 101100 00 101011 : 44 & 43 : $DE002C2B

% 11 10000 0 00000000 00 101110 00 101101 : 46 & 45 : $E0002E2D
% 11 10001 0 00000000 00 110000 00 101111 : 48 & 47 : $E200302F
% 11 10010 0 00000000 00 110010 00 110001 : 50 & 49 : $E4003231
% 11 10011 0 00000000 00 110100 00 110011 : 52 & 51 : $E6003433
% 11 10100 0 00000000 00 110110 00 110101 : 54 & 53 : $E8003635
% 11 10101 0 00000000 00 111000 00 110111 : 56 & 55 : $EA003837
% 11 10110 0 00000000 00 111001 00 111000 : 57 & 56 : $EC003938
% 11 10111 0 00000000 00 111011 00 111010 : 59 & 58 : $EE003B3A

% 11 11000 0 00000000 00 111100 00 111011 : 60 & 59 : $F0003C3B
% 11 11001 0 00000000 00 111101 00 111100 : 61 & 60 : $F2003D3C
% 11 11010 0 00000000 00 111110 00 111101 : 62 & 61 : $F4003E3D
% 11 11011 0 00000000 00 111110 00 111110 : 62 & 62 : $F6003E3E
% 11 11100 0 00000000 00 111111 00 111111 : 63 & 63 : $F8003F3F
% 11 11101 0 00000000 00 111111 00 111111 : 63 & 63 : $FA003F3F
% 11 11110 0 00000000 00 111111 00 111111 : 63 & 63 : $FC003F3F
% 11 11111 0 00000000 00 111111 00 111111 : 63 & 63 : $FE003F3F

```

Table 12-2 – Datagrams for initialization of a quarter sine wave period microstep look-up-table

These 32 datagrams (Table 12-2) are sufficient for all programmable micro step resolutions. If micro stepping is used for at least one stepper motor, these 32 datagrams have to be sent once to the TMC428 for initialization of the micro step table after power-on reset. The initialization of the micro step look-up-table is not necessary, if full stepping is used for *all* stepper motors. The on-chip RAM is not initialized during power-on reset. So, the full initialization of the whole micro step look-up-table is recommended to avoid trouble caused by missing look-up table entries. Additionally, a fully initialized micro step look-up-table allows the selection of individual micro step resolutions for different steppers.

Hint: The previous section describes how to calculate values for the TMC428 sine wave look-up table, and how to write those values into the look-up table RAM of the TMC428 via SPI datagrams. Nevertheless, other formulas might generate sine wave look-up tables that better fit with respect to equidistance of micro steps or concerning torque ripple. Alternatively, a sine wave look-up table based on

$$y(i) = \text{int}[63 * \sin(\frac{1}{4} * 2 * \pi * i / 64)]$$

can be used. Even, adding some offset o within theoretical range from 0 to 63

$$y(i) = \text{int}[o + (63-o) * \sin(\frac{1}{4} * 2 * \pi * i / 64)]$$

might enhance the micro step behavior together with mixed decay. Finally, a sine wave look-up table has to be tested within the application and might need some fine adjustments for optimization.

12.1 Stepping through the Wave Look-Up-Table

The 64 values of the wave look-up table (LUT) hold a quarter period of a sine wave, indexed from 0 to 63. This quarter sine wave is expanded to full sine wave and full cosine wave by indexing the 64 values of the LUT. The LUT index is mapped from a wave index of a full period from 0 to 255. The stepping through the LUT is done with fixed increment width. The increment width is a power of two and it depends on the micro step resolution selection **usrs**. The Table 12-4 gives the indices for the LUT for the different micro step resolutions. For motion in positive direction, the full period index is incremented from micro step to micro step. For motion into negative direction, the full period index is decremented from micro step to micro step.

The sine is associated to phase A (PH_A) and the cosine is associated to phase B (PH_B). The phase bits represent the sign of the sine resp. cosine function. The polarity of the phase bit (PH_A, PH_B) and the polarity of the fast decay control bits (FD_A, FD_B) can be changed by the polarity bits within the global stepper motor parameter register (see section 9.7, page 29).

| MSBs of full wave index (range) | Quadrant | PH_A (sin) | PH_B (cos) | FD_A (sin) | FD_B (cos) |
|---------------------------------|-----------------|------------|------------|------------|------------|
| %00 (0...63) | 1 st | 1 | 1 | 0 | 1 |
| %01 (64...127) | 2 nd | 1 | 0 | 1 | 0 |
| %10 (128...191) | 3 rd | 0 | 0 | 0 | 1 |
| %11 (192...255) | 4 th | 0 | 1 | 1 | 0 |

Table 12-3: Phase Bits and Fast Decay Control Bits

Hints: One should always initialize the whole LUT to be sure to read valid wave values, even if one changes the micro step resolution after some micro steps have been done on higher resolution. Even if one uses e.g. 16 times microstepping, one gets a smoother move for the stepper motor if one initializes the full sine wave LUT according to Table 12-2 – Datagrams for initialization of a quarter sine wave period microstep look-up-table on page 40 and using the MSB DAC bits (DAC_A_5, DAC_A_4, DAC_A_3, DAC_A_2 and DAC_B_5, DAC_B_4, DAC_B_3, DAC_B_2). So, one should always completely initialize the quarter sine wave LUT, no matter what micro step resolution is used. The addressing starts at 0 after power-on reset only. Changing the micro step resolution after some micro steps have been made causes an offset for the addressing that has to be taken into account for positioning a stepper motor.

| usrs | increment width | | 1 st quadrant | 2 nd quadrant | 3 rd quadrant | 4 th quadrant |
|--------------|-----------------|-----|-----------------------------|------------------------------|-----------------------------|----------------------------|
| %110 | 1 | sin | 0,1,2, 3, ..., 61, 62,63, | 63, 63, 62, 61, ..., 3, 2,1, | 0,1,2, 3, ..., 61, 62,63, | 63, 63,62,61, ..., 3, 2,1 |
| | | cos | 63, 63, 62, 61, ..., 2,1, | 0,1,2, 3, ..., 61, 62,63, | 63, 63,62,61, ..., 3, 2,1, | 0,1,2, 3, ..., 61, 62,63 |
| %101 | 2 | sin | 0,2, 4, 6, ..., 58, 60,62, | 63, 60, 58, 56, ..., 4, 2, | 0,2, 4, 6, ..., 58, 60,62, | 63, 60, 58, 56, ..., 4, 2 |
| | | cos | 63, 60, 58, 56, ..., 4, 2, | 0,2, 4, 6, ..., 58, 60,62, | 63, 60, 58, 56, ..., 4, 2, | 0,2, 4, 6, ..., 58, 60,62 |
| %100 | 4 | sin | 0, 4, 8, 12, ..., 56, 60, | 63, 60, 56, ..., 12, 8, 4, | 0, 4, 8, 12, ..., 56, 60, | 63, 60, 56, ..., 12, 8, 4 |
| | | cos | 63, 60, 56, ..., 12, 8, 4, | 0, 4, 8, 12, ..., 56, 60, | 63, 60, 56, ..., 12, 8, 4, | 0, 4, 8, 12, ..., 56, 60 |
| %011 | 8 | sin | 0, 8, 16, 24, ..., 48, 56 | 63, 56, 48, 40, ..., 16, 8, | 0, 8, 16, 24, ..., 48, 56 | 63, 56, 48, 40, ..., 16, 8 |
| | | cos | 63, 56, 48, 40, ..., 16, 8, | 0, 8, 16, 24, ..., 48, 56 | 63, 56, 48, 40, ..., 16, 8, | 0, 8, 16, 24, ..., 48, 56 |
| %010 | 16 | sin | 0, 16, 32, 48, | 63, 48, 32, 16, | 0, 16, 32, 48, | 63, 48, 32, 16 |
| | | cos | 63, 48, 32, 16, | 0, 16, 32, 48, | 63, 48, 32, 16, | 0, 16, 32, 48 |
| %001 (HS) | 32 | sin | 0, 32, | 63, 32, | 0, 32, | 63, 32 |
| | | cos | 63, 32, | 0, 32, | 63, 32 | 0, 32 |
| %000 (FS) | 64 | sin | 0, | 63, | 0, | 63 |
| | | cos | 63, | 0, | 63 | 0 |

Table 12-4: Wave look-up table (LUT) indices for different microstep resolutions

12.2 Partial look-up table initialization option

A partially initialized micro step table may be sufficient, if all stepper motors— except those driven in full step mode —are programmed to use the same micro step resolution constantly before a single micro step is processed. But with a partial initialized micro step look-up table, the micro step resolution *must not be changed* after any step is made after power-on reset. So, a partially initialized look-up table should be taken into account only, if it is a must because of too small memory of the host microcontroller. Instead of partial initialization of the look-up table of the TMC428, initialization with a triangular function $f_{\text{rhomb}}(\varphi)$ would be a better choice.

12.3 Micro Step Enhancement

Even for stepper motors optimized for sine-cosine control, it is possible to improve micro step behavior by adapting the micro step look-up table (LUT). For different types of stepper motors, a periodic trapezoidal or triangular function similar to a sine function or a superposition of these function as a replacement of the pure sine wave function (Figure 12-1) might be a better choice. Taking the physics of stepper motors into account, the choice of the function for microstepping can be determined by a single shape parameter σ as explained below. The programmability of the micro step look-up table provides a simple and effective facility to enhance microstepping for a given type of two-phase stepper motor. Enhanced microstepping requires accurate current control. So, stepper motor driver chips with enabled and well tuned fast decay (resp. mixed decay) operational mode are need to be used, e.g. TRINAMICs smart power TMC236 / TMC239 / TMC246 / TMC249 drivers.

Non-linearity resulting from magnetic field configuration determined by shapes of pole shoes, ferromagnetic characteristics, and other stepper motor characteristics effect non-linearity in micro step behavior of real stepper motors. The non-linearity of microstepping causes micro step positioning displacements, vibrations and noise, which can be reduced dramatically with an adapted micro step table. The best fitting micro step table can be determined by measuring the micro step motor behavior, e.g. using a laser pointer based on the sine-cosine microstepping table.

Nevertheless sine-cosine microstepping is a good first order approach for microstepping. The micro step enhancement possible with the TMC428 is based on replacement of the look-up table initialization function $\sin(\varphi)$ used for sine-cosine microstepping by a function with the shape parameter σ . A quarter sine wave period is the basic approach for initialization of the micro step look-up-table. A quarter of a trapezoidal function or a quarter of a triangular function is chosen depending on the shape parameter σ for a given stepper motor type.

$$f_{\sigma}(\varphi) = \begin{cases} f_{\text{box_circle}}(\varphi) & \text{for } \sigma > 0 \\ f_{\text{circle}}(\varphi) & \text{for } \sigma = 0 \\ f_{\text{circle_rhomb}}(\varphi) & \text{for } \sigma < 0 \end{cases} \quad \text{with} \quad -0.5 \leq \sigma \leq 0.5 \quad \text{and} \quad 0 \leq \varphi < \frac{\pi}{2}$$

The look-up table ($f(\varphi)$) of the TMC428 enfolds a quarter period ($0 \leq \varphi < \pi/2$) only. This quarter period is expanded to a full period ($0 \leq \varphi < 2\pi$) and the phase shifted companion function value ($f(\varphi - \pi/2)$) is added automatically by the TMC428 during operation. So, to reach function value ($f(\varphi)$), one automatically gets a pair of function values $\{f(\varphi); f(\varphi - \pi/2)\}$ respectively $\{\sin(\varphi); \cos(\varphi)\}$. This automatic expansion of the TMC428— primary provided for sine cosine microstepping ($f(\varphi) = \sin(\varphi)$)— also works fine with other micro step wave forms f_{σ} .

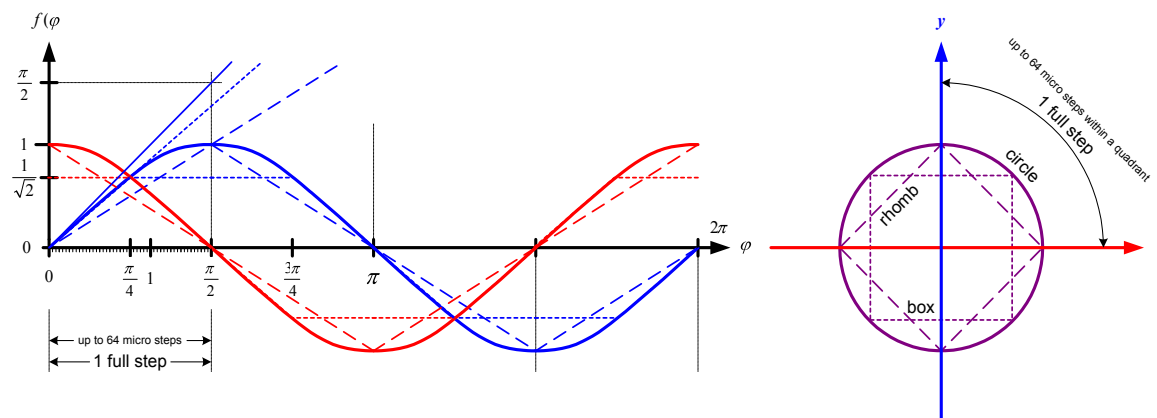

Figure 12-1: Microstep enhancement by introduction of a shape function $f_{\sigma}(\varphi)$

The shape parameter σ selects one of three functions $f_{\text{box}}(\varphi)$, $f_{\text{circle}}(\varphi)$, $f_{\text{rhomb}}(\varphi)$, respectively a superposition of two of them. The shape parameter $\sigma = 0$ selects the function $f_{\text{circle}}(\varphi)$ which is the sine function $\sin(\varphi)$ as used for sine cosine microstepping. With this, one gets the unit circle ($r=1.0$) by transformation to Cartesian coordinates $\{y = \sin(\varphi); x = \cos(\varphi)\}$ as outlined in Figure 12-1, a shape parameter $\sigma = +1.0$ results in a box, and a shape parameter $\sigma = -1.0$ results in a rhomb. Other values except those, result in something between box and circle respectively something between circle and rhomb.

The data values $y(i)$ of the look-up table range from 0 to 63 and the argument I ranges also from 0 to 63. In the following, natural angles (radians) ranging from $(0 \leq \varphi < 2\pi)$ are used for the description. The three functions for superposition controlled by the shape parameter σ are

$$f_{\text{box}}(\varphi) = \begin{cases} \frac{4}{r \cdot \sqrt{2}} \cdot \varphi & \text{if } 0 \leq \varphi < \frac{\pi}{4} \\ \frac{1}{\sqrt{2}} & \text{if } \varphi \geq \frac{\pi}{4} \end{cases}$$

$$f_{\text{circle}}(\varphi) = \sin(\varphi)$$

$$f_{\text{rhomb}}(\varphi) = \frac{2}{\pi} \cdot \varphi$$

All together, these three functions are combined to form the function

$$f_{\sigma}(\varphi) = \begin{cases} f_{\text{circle}}(\varphi) + \sigma [f_{\text{box}}(\varphi) - f_{\text{circle}}(\varphi)] & \text{for } \sigma > 0 \\ f_{\text{circle}}(\varphi) & \text{for } \sigma = 0 \\ f_{\text{circle}}(\varphi) + \sigma [f_{\text{circle}}(\varphi) - f_{\text{rhomb}}(\varphi)] & \text{for } \sigma < 0 \end{cases}$$

So, the shape parameter σ selects the type of function and it also provides a continuous transition between circle and box respectively circle and rhomb. To estimate, what function would be best for a given type of stepper motor, one can try microstepping based on different shape parameters σ by downloading different micro step tables on-the-fly into the TMC428 during motion of a stepper motor. For calculation of data for the micro step look-up table of the TMC428, one has to replace $\varphi \rightarrow \varphi_i$ ranging from 0 to $\pi/2$ for the quarter period by

$$\varphi_i = \frac{\pi}{2} \cdot \frac{i}{64} \quad \text{with } i = \{0, 1, 2, 3, \dots, 63\}.$$

The amplitude of the shape function $f_{\sigma}(\varphi_i)$ has to be limited to the range of 0.0 to 1.0 respectively to the range of 0 to 63 for the on-chip RAM as described in the beginning of the microstepping section.

13 How to get Started in Running a Motor

First of all, the Stepper Motor Driver Datagram Configuration has to be written into its RAM area. Additionally, the Microstep Look-Up-Table has to be initialized when using microstepping. The parameter **LSMD**, that is part of the global parameter register, has to be initialized. After that, the parameters **v_min**, **v_max**, and the clock pre-dividers **pulse_div** and **ramp_div** and the micro step resolution **usrs** has to be set. Then, **a_max** together with a valid pair of **pmul** and **pdiv** has to be set. The switch configuration **ref_conf** together with the ramp mode **rm** has to be chosen. The reference switch inputs **REF1**, **REF2**, **REF3** should be pulled down to ground or disabled by setting **ref_conf**. With those settings, the TMC428 runs a motor if one writes either **x_target** or **v_target**, depending on the choice of the ramp mode **rm**. An application note named "TMC428 – Getting Started" together with C source code examples are available on www.trinamic.com

14 Package Outlines and Dimensions

14.1 Shrink Small Outline Package with 16 Pins (SSOP16, 150 MIL) of TMC428-I and TMC428-A

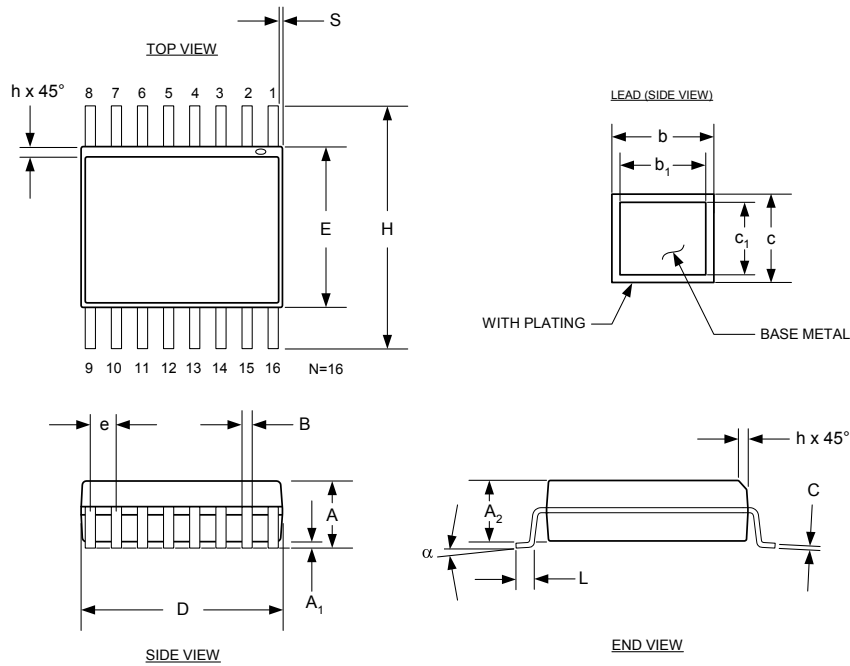

Figure 14-1: Package Outline Drawing SSOP16, 150 MILS

| Symbol | Dimensions in MILLIMETERS | | | Dimensions in INCHES | | |
|--------|---------------------------|-------|-------|----------------------|--------|--------|
| | Min | Typ | Max | Min | Typ | Max |
| A | 1.55 | 1.63 | 1.73 | 0.061 | 0.064 | 0.068 |
| A1 | 0.10 | 0.15 | 0.25 | 0.004 | 0.006 | 0.0098 |
| A2 | 1.40 | 1.47 | 1.55 | 0.055 | 0.058 | 0.061 |
| b | 0.20 | | 0.30 | 0.008 | | 0.012 |
| b1 | 0.20 | 0.25 | 0.28 | 0.008 | 0.010 | 0.011 |
| c | 0.18 | | 0.25 | 0.007 | | 0.010 |
| c1 | 0.18 | 0.20 | 0.23 | 0.007 | 0.008 | 0.009 |
| B | 0.20 | 0.25 | 0.31 | 0.008 | 0.010 | 0.012 |
| C | 0.19 | 0.20 | 0.25 | 0.0075 | 0.008 | 0.0098 |
| D | 4.80 | 4.93 | 4.98 | 0.189 | 0.194 | 0.196 |
| E | 3.91 BSC | | | 0.154 BSC | | |
| e | 0.635 BSC | | | 0.025 BSC | | |
| H | 6.02 BSC | | | 0.237 BSC | | |
| h | 0.25 | 0.33 | 0.41 | 0.010 | 0.013 | 0.016 |
| L | 0.41 | 0.635 | 0.89 | 0.016 | 0.025 | 0.035 |
| N | 16 | | | 16 | | |
| S | 0.051 | 0.114 | 0.178 | 0.0020 | 0.0045 | 0.0070 |
| α | 0° | 5° | 8° | 0° | 5° | 8° |

Table 14-1: Dimensions of Package SSOP16, 150 MILS (Note: BSC ≈ Best Case)

14.2 Small Outline Package with 24 Pins (SOP24) of TMC428-PI24

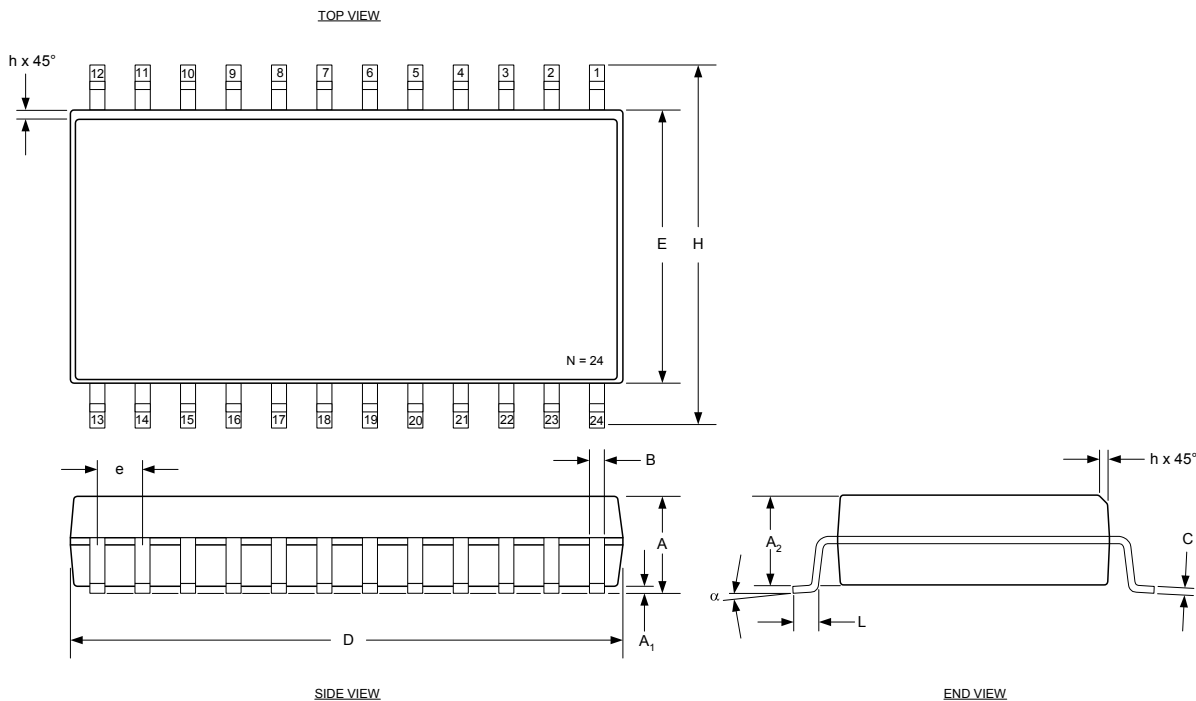

Figure 14-2: Package Outline Drawing SOP24, 300 MILS

| Symbol | Dimensions in MILLIMETERS | | | Dimensions in INCHES | | |
|--------|---------------------------|-----|-------|----------------------|-----|--------|
| | Min | Typ | Max | Min | Typ | Max |
| A | 2.35 | | 2.65 | 0.0926 | | 0.1043 |
| A1 | 0.1 | | 0.3 | 0.004 | | 0.0118 |
| A2 | | | | | | |
| B | 0.33 | | 0.51 | 0.013 | | 0.02 |
| C | 0.23 | | 0.32 | 0.0091 | | 0.0125 |
| D | 15.2 | | 15.6 | 0.5985 | | 0.6141 |
| E | 7.4 | | 7.6 | 0.2914 | | 0.2992 |
| e | 1.27 BSC | | | 0.05 BSC | | |
| H | 10 | | 10.65 | 0.394 | | 0.419 |
| h | 0.25 | | 0.75 | 0.01 | | 0.029 |
| L | 0.4 | | 1.27 | 0.016 | | 0.05 |
| N | 24 | | | 24 | | |
| α | 0° | | 8° | 0° | | 8° |

Table 14-2: Dimensions of Package SOP24, 300 MILS (Note: BSC ≈ Best Case)

14.3 Dual-In-Line Package with 20 Pins (DIL20) of TMC428-DI20

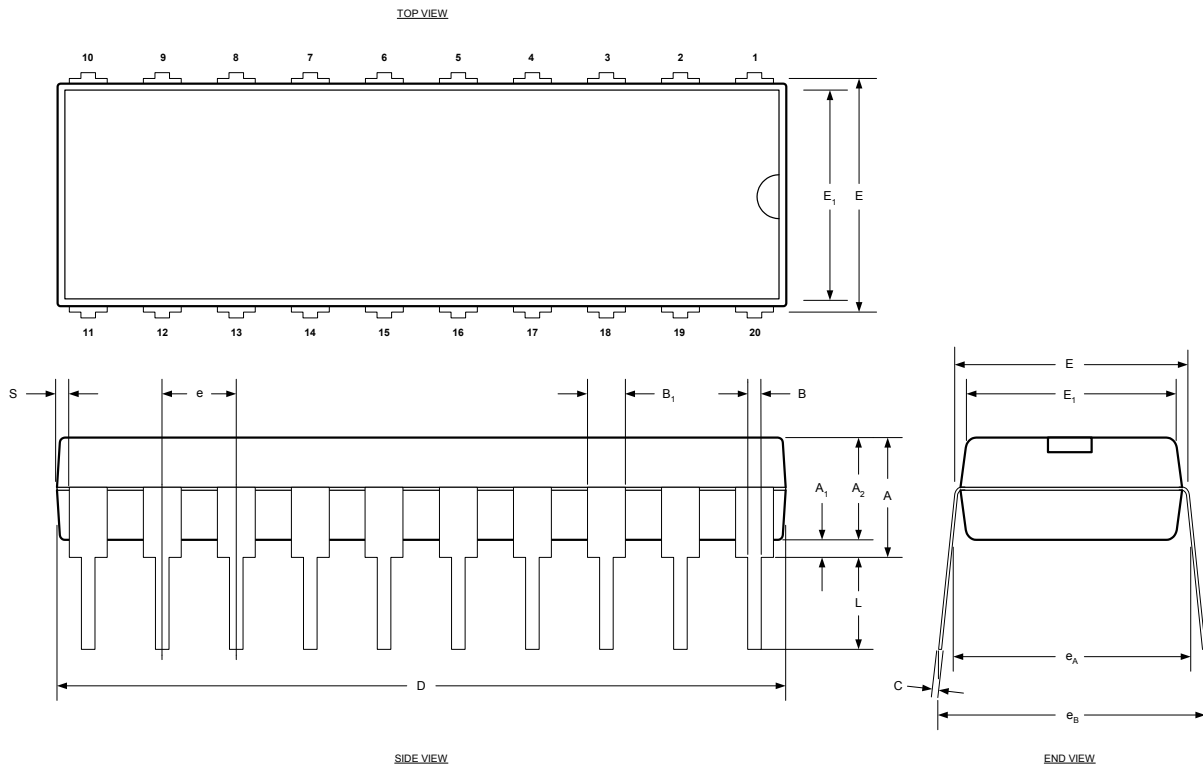





Figure 14-3: Package Outline Drawing DIL20, 300 MILS (not recommended for new designs)



| Symbo l | Dimensions in MILLIMETERS | | | Dimensions in INCHES | | |
|------------|---------------------------|-------|-------|----------------------|-------|-------|
| | Min | Typ | Max | Min | Typ | Max |
| A | | | 4.57 | | | 0.180 |
| A1 | 0.38 | | | 0.015 | | |
| A2 | 3.05 | 3.43 | 3.81 | 0.120 | 0.135 | 0.150 |
| B | 0.36 | 0.46 | 0.56 | 0.014 | 0.018 | 0.022 |
| B1 | 1.14 | 1.27 | 1.52 | 0.045 | 0.050 | 0.060 |
| C | 0.20 | 0.25 | 0.38 | 0.008 | 0.010 | 0.015 |
| D | 24.0 | 24.51 | 25.02 | 0.945 | 0.965 | 0.985 |
| D1 | 22.86 BSC | | | 0.900 BCS | | |
| E | 7.62 | 7.87 | 8.26 | 0.300 | 0.310 | 0.325 |
| E1 | 6.99 | 7.24 | 7.49 | 0.275 | 0.285 | 0.295 |
| e | 2.54 BSC | | | 0.100 BSC | | |
| eA | 7.62 BSC | | | 0.300 BSC | | |
| eB | | | 10.92 | | | 0.430 |
| L | 2.79 | 3.30 | 3.81 | 0.110 | 0.130 | 0.150 |
| S | 0.13 | | | 0.005 | | |
| N | 20 | | | 20 | | |

Table 14-3: Dimensions of Package DIL20, 300 MILS (Note: BSC ≈ Best Case)

15 Marking

| | |
|-----------------------------|---|
| Product Name | TMC428-I |
| Product ID at top | 56563A |
| Package | SSOP16 – 150 MILS |
| Date Code (at bottom only) | YYWW (year YY and week WW) |
| Lot Number (at bottom only) | XXXXXXXXXX |
| Logo | No |
| Real Size (see note below) |  |
| Zoomed Size |  |

| | |
|-----------------------------|---|
| Product Name | TMC428-A |
| Product ID at top | 56563A |
| Package | SSOP16 – 150 MILS |
| Date Code (at bottom only) | YYWW (year YY and week WW) |
| Lot Number (at bottom only) | XXXXXXXXXX |
| Logo | No |
| Real Size (see note below) |  |
| Zoomed Size |  |

| | |
|----------------------------|---|
| Product Name | TMC424-PI24 |
| Product ID | 56563A |
| Package | SOP24 – 300 MILS |
| Date Code | YYWW (year YY and week WW) |
| Lot Number | XXXXXXXXXX |
| Logo | Yes |
| Real Size (see note below) |  |
| Zoomed Size |  |

Note: Provided to be of “Real Size” if printed with scale of 100% on paper of DIN-A4 format – but the printed size may differ depending on the printer.

16 On-Chip Voltage Regulator

The on-chip voltage regulator delivers a 3.3V supply for the chip core. An external 470 nF ceramic capacitor has to be connected between the V33 pin (see Figure 16-1, page 49) and ground, with connections as short as possible. Additionally, an external 100 nF ceramic capacitor (CBLOCK) has to be connected between pin V5 and ground— with connections as short as possible—in 5V operational mode. In 3.3V operational mode an external 100 nF ceramic capacitor (see Figure 16-1, page 49) is necessary only between pin V33 and ground, with connections as short as possible.

| Symbol | Parameter | Conditions | Min | Typ | Max | Unit |
|----------|-------------------------------|---|-----|-----|-----|----------|
| TRANGERE | Temperature range | Industrial | -40 | | 85 | °C |
| VDD5REG | Supply voltage vdd5 | 5 V Operational Mode | 4.5 | 5 | 5.5 | V |
| CBLOCK | Block capacitor | 5 V Operational Mode, x7r ceramic capacitor | | 100 | | nF |
| VDD3REG | Supply voltage vdd3 | 3.3 V Operational Mode | 2.9 | 3.3 | 3.6 | V |
| ICCNLREG | Current consumption | no load | | 50 | 100 | µA |
| tSREG | Startup time | no external capacitor connected | | | 20 | µs |
| tSREGC | Startup time | C_load = 470 nF | | | 150 | µs |
| TDRFT | Temperature drift | | | | 300 | ppm / °C |
| VRIPPLE | Ripple on vdd3 | With ripple over 50 mV the input thresholds may differ from that specified in the data sheet | | | 100 | mV |
| CREG | External capacitor | On V33 pin, x7r ceramic, necessary capacity depending on ripple requirements. Using external capacitor with capacity other than typical, the ripple should be measured on pin v33 to be sure that requirements are satisfied. | 33 | 470 | | nF |
| COPT | Optional capacitor | Optional parallel capacitor for additional reduction of high frequency ripple, c0g ceramic, unnecessary in most cases | | 470 | | pF |
| PSRRDC | power supply ripple rejection | DC | | 50 | | dB |

Table 16-1: Characteristics of the on-chip voltage regulator

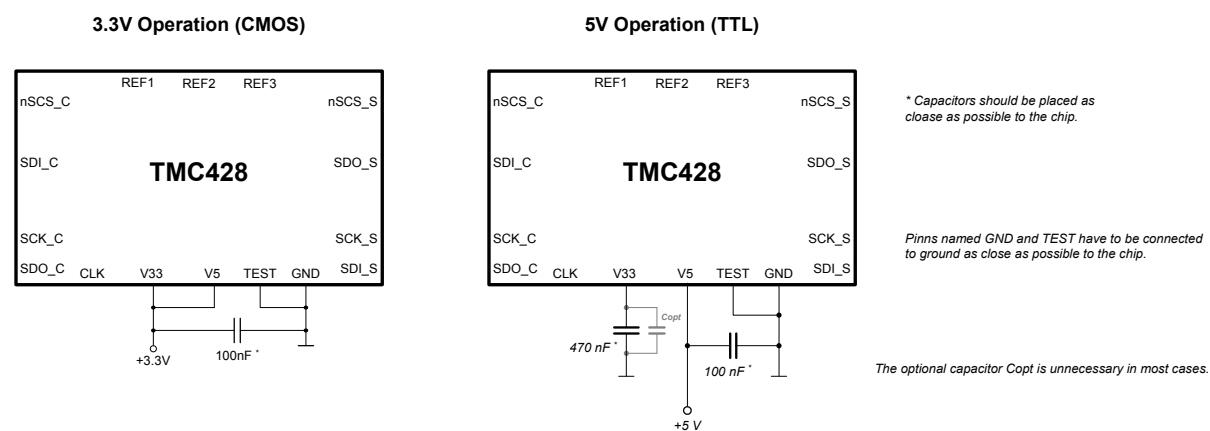

Figure 16-1: 3.3V operation (CMOS) vs. 5V operation (TTL)

17 Power-On-Reset

The TMC428 is equipped with a static and dynamic reset with internal hysteresis (see Figure 17-1). So, it performs an automatic reset during power-on. If the power supply voltage goes below a threshold, an automatic power on reset is performed also. The power on reset time t_{RESPOR} also depends on the power up time of the on-chip voltage regulator (see Table 16-1).

| Symbol | Parameter | Conditions | Min | Typ | Max | Unit |
|---------|--------------------------------------|------------|------|------|------|------|
| VDD | Power supply range | | 3.0 | 3.3 | 3.6 | V |
| Temp | Temperature | | -55 | 25 | 125 | °C |
| Vop | Reset on/off | | | | 0.80 | V |
| Voff | Reset off | | 1.58 | 2.13 | 2.85 | V |
| Von | Reset on | | 1.49 | 1.98 | 2.70 | V |
| tRESPOR | Reset time of on-chip power-on-reset | | 2.14 | 3.31 | 5.52 | µs |

Table 17-1: Characteristics of the on-chip power-on-reset

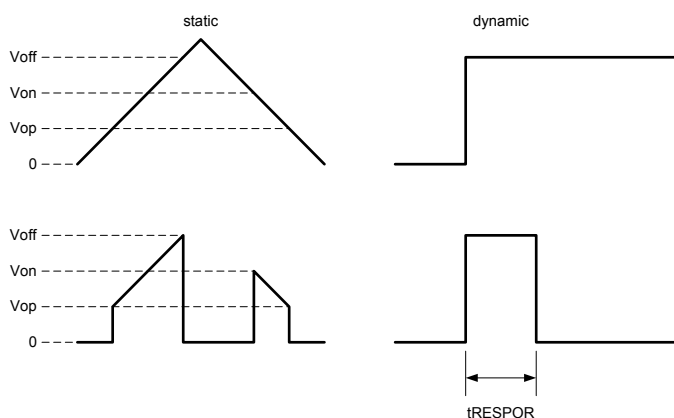

Figure 17-1: Operating principle of the power-on-reset

18 Characteristics

| Symbol | Parameter | Conditions | Min | Max | Unit |
|---------|-------------------------------|--|------|---------------------|------|
| VDD3 | DC Supply Voltage | Voltage at Pin V33 in 3.3V mode | -0.3 | 3.6 | V |
| VI3 | DC Input Voltage, 3.3 V I/Os | | -0.3 | VDD3 + 0.3 | V |
| VO3 | DC Output Voltage, 3.3 V I/Os | | -0.3 | VDD3 + 0.3 | V |
| VDD5 | DC Supply Voltage | Voltage at Pin V5 | -0.3 | 5.5 | V |
| VI5 | DC Input Voltage, 5V I/Os | Continuous DC Voltage | -0.3 | VDD5 + 0.3, 5.5 max | V |
| VO5 | DC Output Voltage, 5V I/Os | Continuous DC Voltage | -0.3 | VDD5 + 0.3, 5.5 max | V |
| VESD | ESD Voltage | PAD cells are designed to resist ESD voltages according to Human Body Model according to MIL-STD-883, with $R_C = 1 - 10 \text{ M}\Omega$, $R_D = 1.5 \text{ K}\Omega$, and $C_S = 100 \text{ pF}$, but it can not be guaranteed. | | ± 2000 | V |
| TEMP_D2 | Ambient Air Temperature Range | Industrial / Consumer type | -40 | +85 | °C |
| TEMP_D3 | Ambient Air Temperature Range | Automotive type | -55 | +125 | °C |
| TEMP_D4 | Ambient Air Temperature Range | Industrial type | -40 | +105 | °C |
| TSG | Storage Temperature | | -60 | +150 | °C |

Table 18-1 : Absolute maximum ratings

| Symbol | Parameter | Conditions | Min | Typ | Max | Unit |
|--------|-----------------------|------------|-----|-----|-----|---------------|
| ILC | Input Leakage Current | | | | 1 | μA |
| CIN | Input Capacitance | | | 7 | | pF |

Table 18-2: DC characteristics

| Symbol | Parameter | Conditions | Min | Typ | Max | Unit |
|--------|------------------------------------|------------------------|--------------------------|-----|--------------------------|------|
| VDD3 | DC Supply Voltage | | 3.0 | 3.3 | 3.6 | V |
| VI3 | DC Input Voltage | | 0 | | VDD3 | V |
| VIL3 | Low Level Input Voltage | Pin TEST only | 0 | | $0.3 \times \text{VDD3}$ | V |
| VIH3 | High Level Input Voltage | Pin TEST only | $0.7 \times \text{VDD3}$ | | VDD3 + 0.3 | V |
| VLTH3 | Low Level Input Voltage Threshold | All Inputs except TEST | 0.9 | | 1.2 | V |
| VHTH3 | High Level Input Voltage Threshold | All Inputs except TEST | 1.5 | | 1.9 | V |
| VHYS3 | Schmitt-Trigger Hysteresis | | 0.4 | | 0.7 | V |
| VOL3 | Low Level Output Voltage | IOL = 0.3 mA | | | 0.1 | V |
| VOH3 | High Level Output Voltage | IOH = 0.3 mA | VDD3 - 0.1 | | | V |
| VOL3 | Low Level Output Voltage | IOL = 2 mA | | | 0.4 | V |
| VOH3 | High Level Output Voltage | IOH = 2 mA | VDD3 - 0.4 | | | V |

Table 18-3: DC characteristics – 3.3V supply mode

Note: Ripple on VDD3 has to be taken into account concerning measurement of thresholds and hysteresis.

| Symbol | Parameter | Conditions | Min | Typ | Max | Unit |
|--------|------------------------------------|---------------------------------|--------------------------|-----|--------------------------|------|
| VDD5 | DC Supply Voltage | | 4.5 | 5 | 5.5 | V |
| VI5 | DC Input Voltage | | 0 | | VDD5 | V |
| VIL5 | Low Level Input Voltage | Pin TEST only | 0 | | $0.3 \times \text{VDD5}$ | V |
| VIH5 | High Level Input Voltage | Pin TEST only | $0.7 \times \text{VDD5}$ | | VDD5 + 0.3 | V |
| VLTH5 | Low Level Input Voltage Threshold | All Inputs except TEST, VDD5=5V | 0.9 | | 1.2 | V |
| VHTH5 | High Level Input Voltage Threshold | All Inputs except TEST, VDD5=5V | 1.5 | | 1.9 | V |
| VHYS5 | Schmitt-Trigger Hysteresis | | 0.4 | | 0.7 | V |
| VOL5 | Low Level Output Voltage | IOL = 0.3 mA | | | 0.1 | V |
| VOH5 | High Level Output Voltage | IOH = 0.3 mA | VDD5 - 0.1 | | | V |
| VOL5 | Low Level Output Voltage | IOL = 4 mA | | | 0.4 | V |
| VOH5 | High Level Output Voltage | IOH = 4 mA | VDD5 - 0.4 | | | V |

Table 18-4: DC characteristics – 5V supply mode

| Symbol | Parameter | Conditions | Min | Typ | Max | Unit |
|----------|--------------------|---------------------------------------|-----|------|-----|------|
| ISC16MHZ | Supply Current | f = 16 MHz at Tc=25°C | | 5 | 10 | mA |
| ISC4MHZ | Supply Current | f = 4 MHz at Tc=25°C | | 1.25 | 2.5 | mA |
| IPDN25C | Power Down Current | Power Down Mode at Tc=25°C, 5V Supply | | 70 | 150 | µA |

Table 18-5: Power dissipation

| Symbol | Parameter | Conditions | Min | Typ | Max | Unit |
|---------|-------------------------|--|------|-----|-----|------|
| fCLK | Operation Frequency | fCLK = 1 / tCLK | 0 | 4 | 16 | MHz |
| tCLK | Clock Period | Raising Edge to Raising Edge of CLK | 62.5 | | ∞ | ns |
| tCLK_L | Clock Time Low | | 25 | | ∞ | ns |
| tCLK_H | Clock Time High | | 25 | | ∞ | ns |
| tRISE_I | Input Signal Rise Time | 10% to 90% except TEST pin | 0.5 | | ∞ | ns |
| tFALL_I | Input Signal Fall Time | 90% to 10% except TEST pin | 0.5 | | ∞ | ns |
| tRISE_O | Output Signal Rise Time | 10% to 90% | | 3 | | ns |
| tFALL_O | Output Signal Fall Time | 90% to 10% | | 3 | | ns |
| tSU | Setup Time | relative to falling clock edge at CLK | 1 | | | ns |
| tHD | Hold Time | relative to falling clock edge at CLK | 1 | | | ns |
| tPD | Propagation Delay Time | 50% of rising edge of the clock CLK to the 50% of the output | 1 | 5 | | ns |

Table 18-6: General timing parameters

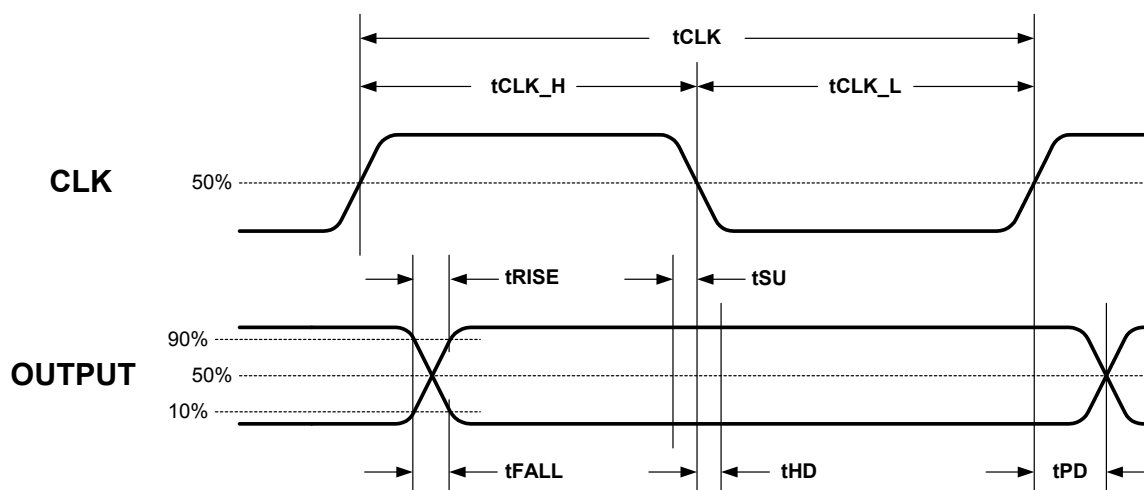

Figure 18-1: General timing parameters

19 Example for Calculation of p_mul and p_div for the TMC428

```

/* PROGRAM EXAMPLE 'pmlpdiv.c' : How to Calculate p_mul & p_div for the TMC428 */

#include <math.h>
#include <stdio.h>
#include <stdlib.h>
#include <string.h>

void CalcPMulPDiv(int a_max, int ramp_div, int pulse_div, float p_reduction,
                 int *p_mul, int *p_div, double *PIdeal, double *PBest, double *PRedu )
{
    int    pdiv, pmul, pm, pd ;
    double p_ideal, p_best, p, p_reduced;

    pm=-1; pd=-1; // -1 indicates : no valid pair found
    p_ideal  = a_max / (pow(2, ramp_div-pulse_div)*128.0);
    p        = a_max / ( 128.0 * pow(2, ramp_div-pulse_div) );
    p_reduced = p * ( 1.0 - p_reduction );

    for (pdiv=0; pdiv<=13; pdiv++)
    {
        pmul = (int)(p_reduced * 8.0 * pow(2, pdiv)) - 128;

        if ( (0 <= pmul) && (pmul <= 127) )
        {
            pm = pmul + 128;
            pd = pdiv;
        }
    }

    *p_mul = pm;
    *p_div = pd;

    p_best = ((double)(pm)) / ((double)pow(2,pd+3));

    *PIdeal = p_ideal;
    *PBest  = p_best;
    *PRedu  = p_reduced;
}

int main(int argc, char **argv)
{
    int  a_max=0, ramp_div=0, pulse_div=0, p_mul, p_div,
        a_max_lower_limit=0, a_max_upper_limit=0;
    double pideal, pbest, predu;
    float  p_reduction=0.0;

    char **argp;

    if (argc>1)
    {
        while (argv++, argc--)
        {
            argp = argv + 1;  if (*argp==NULL) break;

            if ( (!strcmp(*argp,"-a")) ) sscanf(*argp,"%d",&a_max);
            else if ( (!strcmp(*argp,"-r")) ) sscanf(*argp,"%d",&ramp_div);
            else if ( (!strcmp(*argp,"-p")) ) sscanf(*argp,"%d",&pulse_div);
            else if ( (!strcmp(*argp,"-pr")) ) sscanf(*argp,"%f",&p_reduction);
        }
    }
    else
    {
        fprintf(stderr,"\n USAGE : pmlpdiv -a <a_max> -r <ramp_div> -p <pulse_div> -pr <0.00 .. 0.10>\n"
                "    EXAMPLE : pmlpdiv -a 10 -r 3 -p 3 -pr 0.05\n");
        return 1;
    }

    printf("\n\n  a_max=%d\tramp_div=%d\tpulse_div=%d\tp_reduction=%f\n\n",
           a_max, ramp_div, pulse_div, p_reduction);

    CalcPMulPDiv(a_max, ramp_div, pulse_div, p_reduction, &p_mul, &p_div, &pideal, &pbest, &predu );

    printf("  p_mul = %3.3d\n  p_div = %3d\n\n  p_ideal = %f\n  p_best = %f\n  p_redu = %f\n\n",
           p_mul, p_div, pideal, pbest, predu);

    a_max_lower_limit = (int)pow(2, (ramp_div-pulse_div-1));
    printf("\n  a_max_lower_limit = %d", a_max_lower_limit);
    if (a_max < a_max_lower_limit) printf(" [WARNING: a_max < a_max_lower_limit]");
    a_max_upper_limit = ((int)pow(2, (12+(ramp_div-pulse_div)))) - 1;
    printf("\n  a_max_upper_limit = %d", a_max_upper_limit);
    if (a_max > a_max_upper_limit) printf(" [WARNING: a_max > a_max_upper_limit]");
    printf("\n\n");

    return 0;
}
/* ----- */

```

20 Revision History

| Version | Date (Author) | Comment |
|---------|-------------------------------------|--|
| 1.00 | February 23, 2001 (LL) | First complete version published in printed form |
| 1.01 | March 27, 2001 (LL) | Version updated based on customer feed back |
| 1.02 | November 21, 2001 (LL) | Version published on www.trinamic.com and TECHlibCD |
| 2.00 | October 2, 2003 (LL) | Changed to font Arial, numbering added to headings, revision history added |
| 2.00 | November 12, 2003 (LL) | additional hints concerning motion parameters units and signed representation and concerning signal polarities (see section 2.5, page 5), hint added concerning SPI timing of μ C interface section 6.2 on page 8, hint concerning power-on reset initialization values added near Table 7-2 on page 15, LP bit position corrected @ Table 7-2 on page 15 and Table 8-5 on page 24, limit parameter <code>a_max_upper_limit</code> similar to <code>a_max_lower_limit</code> added as new sub-section (see page 17), interrupt register index (hint within text, section 8.13, page 24) corrected to <code>IDX=%1011</code> , additional statements concerning the functional difference of stop switch and reference switch in context of parameter <code>dx_ref_tolerance</code> section 8.15 on page 27, hints concerning MSB order concerning sending and receiving via the μ C SPI interface, hints concerning the functional difference between stop switch and reference switch, description concerning latching the position (under control of REF_RnL bit) corrected is section 8.16 on page 27, function of the CDGW status bit explained in more detail concerning <code>datagram_high_word</code> and <code>datagram_low_word</code> (section 9.1 on page 27) and <code>cover_datagram</code> (section 9.3 on page 28), correction of maximum value of <code>clk2_div</code> and formula to calculate the datagram frequency <code>f_datagram[Hz]</code> added to section 9.7 on page 29, numbering within table of table concerning Table 9-2: Global parameter LSMD (last stepper motor driver) on page 30 corrected, Figure 11-1 on page 36 added to outline the driver chain configuration principle, imaginary example for Stepper Motor Driver Datagram Configuration (see page 38) changed to real example for the TMC236 / TMC239 / TMC246 / TMC249 family, section 12.1 (page 41) concerning indexing the wave LUT added, optional capacitor <code>Copt</code> added to drawing Figure 16-1 on page 49, calculation of the number of steps during acceleration added to section 8.14, Table 18-1 on page 51 temperature ranges completed, example <code>'p_mulpdiv.c'</code> on page 53 for calculation of <code>p_mul</code> & <code>p_div</code> replaced by a more efficient one |
| 2.00 | October 1 st , 2004 (LL) | Changes concerning new company TRINAMIC Motion Control GmbH & Co. KG |
| 2.01 | October 7 th , 2004 (LL) | One of twice repeated phrase "A write to one of these ..." removed within section 9.1 on page 27, equation " $ \text{ramp_div} \text{ and pulse_div} \leq 1$ " corrected (<i>and</i> replaced by -) section 8.7.1 on page 17, formula $q = p/p'$ corrected to $q = p'/p$ within section 8.11. |
| 2.02 | April 21 th , 2006 (LL) | Hints added (section 3, page 5, Table 3-1; section 4, page 6, Figure 4-1, page 6, Table 4-1, page 6; section 14.3, page 47, Figure 14-3) not to use the package DIL20 variant for new designs – <i>pls. contact our sales via info@trinamic.com for details concerning last order etc.</i> ; specification of industrial temperature range added to section 3, page 5, Table 3-1; hexadecimal representation in Table 12-2 on page 40 <code>% 11 01111 0 00000000 00 101100 00 101011 : 44 & 43 : \$DE001C1B</code> corrected to <code>% 11 01111 0 00000000 00 101100 00 101011 : 44 & 43 : \$DE002C2B</code> ; mnemonic for RAM data of code \$04 changed from <code>DAC_A_3</code> to correct <code>DAC_A_4</code> (Table 11-2, page 38); formula for continuous update frequency (<code>f_cupd_s[Hz]</code>) corrected (end of section 9.7); high active interrupt status bit (former named <code>nINT</code>) renamed to <code>INT</code> to avoid confusing caused by the low active interrupt status output signal (still named <code>SDO_C / nINT</code>), section 6.4, page 11, Table 6-4, page 12, section 6.5, page 13, section 8.13, page 24; hint to an application note "TMC428 – Getting Started" available on www.trinamic.com added section 13, page 44. |
| 2.02 | April 26 th , 2006 (LL) | section 1, page 1 DIL20 package option removed from feature list; hint added not to use the DIL20 package (TMC428-DI20) for new designs (Figure 2-2, page 4); hint added how to make the <code>SDO_C</code> high impedance (Figure 4, page 9); this version of the data sheet is published on www.trinamic.com and TECHlibCD |

| | | |
|------|---------------------------------------|--|
| 2.03 | December 18 th , 2008 (LL) | end of section 8.12 lp & ref_conf & ramp_mode (rm) (IDX=%1010) and table 8.4 v_max (IDX=%0011) corrected concerning x_latched that processes on <i>each signal edge</i> and not only on rising signal edges; section 8.16 x_latched (IDX=%1110) on page 27 corrected concerning x_latched that processes on <i>each signal edge</i> and not only on rising signal edges; hint concerning RoHS compliance for the available variants TMC428-I and TMC428-PI24 added in section 3 Package Variants on page 5; section 6.5; section 6.5 Simple Datagram Examples corrected, page 13; RE1_LEFT corrected in REF1_LEFT in Table 9-3: Association of reference inputs depending on configuration bits refmux & mot1r, page 33; section 20 Revision History (page 54) added to the Table of Contents (TOC), author's initials added to date column of the revision history for internal documentation purposes; section 2.6 Representation of Signed Values by Two's Complement, page 5 correction of a_threshold; section 8.9 is_agtat & is_aleat & is_v0 & a_threshold (IDX=%1000), page 18 update, correction, and hints concerning setting of a_threshold > 1023; table Table 8-2: Current scale selection scheme updated concerning a_threshold > 1023 and hint added. A hint concerning inputs REF1, REF2, REF3 added in section 4, page 6. |
| 2.04 | May 25, 2009 (LL) | section 8.16 page 27 (if when corrected to when); |
| 2.05 | May 28, 2010 (LL) | Hint added concerning changing of pluse_div while VELOCITY_MODE or HOLD_MODE that might force an internal step pulse depending on the current position (section 8.14 pulse_div & ramp_div & usrs (IDX=%1100) page 26); |

21 Table of Figures

| | |
|---|----|
| Figure 2-1: TMC428 application environment with TMC428 in SSOP16 package..... | 3 |
| Figure 2-2: Usage of drivers without serial data output (SDO) with TMC428 in larger packages (<i>*the DIL20 package variant is not recommended for new designs</i>) | 4 |
| Figure 4-1: TMC428 pin out (<i>*the DIL20 package variant is not recommended for new designs</i>)..... | 6 |
| Figure 5-1: TMC428 functional block diagram..... | 7 |
| Figure 6-1: Timing diagram of the serial μ C interface | 8 |
| Figure 4 : Making the TMC428 SDO_C output high impedance with single gate 74HCT1G125 | 9 |
| Figure 6-3: Timing diagram of the serial stepper motor driver interface..... | 10 |
| Figure 8-1: Velocity ramp parameters and velocity profiles..... | 16 |
| Figure 8-2: Ramp generator and pulse generator | 20 |
| Figure 8-3: Proportionality parameter p and outline of velocity profile(s) | 21 |
| Figure 8-4: Left switch and right switch for reference search and automatic stop function..... | 23 |
| Figure 9-1: Example of status bit mapping for a chain of three TMC246 or TMC249 | 27 |
| Figure 9-2: Cover datagram example..... | 28 |
| Figure 9-3: Reference switch configuration 'left-side-only' for mot1r=0 (and refmux=0)..... | 32 |
| Figure 9-4: Reference switch configuration 'two-one-null' for mot1r=1 (and refmux=0)..... | 32 |
| Figure 9-5: Reference switch multiplexing with 74HC157 (refmux=1) | 32 |
| Figure 9-6: Triple switch configuration 'left stop switch – reference switch – right stop switch' | 33 |
| Figure 9-7: Reference search..... | 34 |
| Figure 9-8: Reference switch gateing for exact simultaneous stepper motor start | 34 |
| Figure 11-1: Serially transmitted control and status signals between TMC428 and driver chain | 36 |
| Figure 12-1: Microstep enhancement by introduction of a shape function $f_{\sigma}(\varphi)$ | 43 |
| Figure 14-1: Package Outline Drawing SSOP16, 150 MILS | 45 |
| Figure 14-2: Package Outline Drawing SOP24, 300 MILS..... | 46 |
| Figure 14-3: Package Outline Drawing DIL20, 300 MILS (not recommended for new designs)..... | 47 |
| Figure 16-1: 3.3V operation (CMOS) vs. 5V operation (TTL)..... | 49 |
| Figure 17-1: Operating principle of the power-on-reset..... | 50 |
| Figure 18-1: General timing parameters..... | 52 |

22 Table of Tables

| | |
|--|----|
| Table 3-1: TMC428 package variants | 5 |
| Table 4-1: TMC428 pin out (<i>*the DIL20 package variant is not recommended for new designs</i>) | 6 |
| Table 6-1: Timing characteristics of the serial microcontroller interface | 10 |
| Table 6-2: Timing characteristics of the serial stepper motor driver interface..... | 10 |
| Table 6-3 : 32 bit DATAGRAM structure sent from μ C (MSB sent first) | 11 |
| Table 6-4: 32 bit DATAGRAM structure received by μ C (MSB received first)..... | 12 |
| Table 7-1: TMC428 address space partitions..... | 14 |
| Table 7-2: TMC428 register address mapping..... | 15 |
| Table 8-1: Coil current scale factors..... | 18 |
| Table 8-2: Current scale selection scheme | 19 |
| Table 8-3 – Outline of TMC428 motion modes | 22 |
| Table 8-4: Reference switch configuration bits (ref_conf) | 23 |
| Table 8-5: lp & ref_conf & ramp_mode (rm) data bit positions..... | 24 |
| Table 8-6: interrupt bit mnemonics | 25 |
| Table 8-7: interrupt register & interrupt mask..... | 25 |
| Table 8-8: micro step resolution selection (usr) parameter | 26 |
| Table 9-1: Stepper motor global parameter register..... | 30 |
| Table 9-2: Global parameter LSMD (last stepper motor driver) | 30 |
| Table 9-3: Association of reference inputs depending on configuration bits refmux & mot1r | 33 |
| Table 10-1: Partitioning of the on-chip RAM address space | 35 |
| Table 11-1: Primary signal codes | 37 |
| Table 11-2: Datagram example and RAM contents for three stepper motor driver chain..... | 38 |
| Table 11-3: Configuration datagram sequence for the example (with ‘-’ (don't cares))..... | 39 |

| | |
|---|----|
| Table 12-1: Scheme of ¼ sine wave period with 6 bit resolution and 64 (32 x 2) values | 40 |
| Table 12-2 – Datagrams for initialization of a quarter sine wave period microstep look-up-table | 40 |
| Table 12-3: Phase Bits and Fast Decay Control Bits..... | 41 |
| Table 12-4: Wave look-up table (LUT) indices for different microstep resolutions | 42 |
| Table 14-1: Dimensions of Package SSOP16, 150 MILS (Note: BSC ≈ Best Case) | 45 |
| Table 14-2: Dimensions of Package SOP24, 300 MILS (Note: BSC ≈ Best Case) | 46 |
| Table 14-3: Dimensions of Package DIL20, 300 MILS (Note: BSC ≈ Best Case) | 47 |
| Table 16-1: Characteristics of the on-chip voltage regulator | 49 |
| Table 17-1: Characteristics of the on-chip power-on-reset..... | 50 |
| Table 18-1 : Absolute maximum ratings | 51 |
| Table 18-2: DC characteristics | 51 |
| Table 18-3: DC characteristics – 3.3V supply mode | 51 |
| Table 18-4: DC characteristics – 5V supply mode | 51 |
| Table 18-5: Power dissipation | 52 |
| Table 18-6: General timing parameters..... | 52 |

23 Table of Contents

| | |
|--|-----------|
| 1 Features..... | 1 |
| 2 General Description | 3 |
| 2.1 Step Frequencies | 4 |
| 2.2 Modes of Motion..... | 4 |
| 2.3 Notation of Number Systems & Notation of Two to the Power of n | 5 |
| 2.4 Signal Polarities..... | 5 |
| 2.5 Units of Motion Parameters..... | 5 |
| 2.6 Representation of Signed Values by Two's Complement | 5 |
| 2.7 Tables of Contents | 5 |
| 3 Package Variants..... | 5 |
| 4 Pinning | 6 |
| 5 Functional Description and Block Diagram..... | 7 |
| 6 Serial Peripheral Interfaces | 8 |
| 6.1 Automatic Power-On Reset..... | 8 |
| 6.2 Serial Peripheral Interface for µC..... | 8 |
| 6.3 Serial Peripheral Interface to Stepper Motor Driver Chain..... | 9 |
| 6.4 Datagram Structure..... | 11 |
| 6.5 Simple Datagram Examples | 13 |
| 7 Address Space Partitions | 14 |
| 7.1 Read and Write | 14 |
| 7.2 Register Set..... | 14 |
| 7.3 RAM Area..... | 14 |
| 8 Register Description | 16 |
| 8.1 x_target (IDX=%0000)..... | 16 |
| 8.2 x_actual (IDX=%0001) | 16 |
| 8.3 v_min (IDX=%0010)..... | 16 |
| 8.4 v_max (IDX=%0011)..... | 17 |
| 8.5 v_target (IDX=%0100)..... | 17 |
| 8.6 v_actual (IDX=%0101)..... | 17 |
| 8.7 a_max (IDX=%0110)..... | 17 |
| 8.7.1 a_max_lower_limit & a_max_upper_limit for ramp_div ≠ pulse_div | 17 |
| 8.8 a_actual (IDX=%0111)..... | 18 |

| | | |
|-----------|---|-----------|
| 8.9 | is_agtat & is_aleat & is_v0 & a_threshold (IDX=%1000) | 18 |
| 8.10 | pmul & pdiv (IDX=%1001) | 19 |
| 8.11 | Calculation of p_mul and p_div | 21 |
| 8.11.1 | <i>Optimized Calculation of p_mul and p_div</i> | 22 |
| 8.12 | lp & ref_conf & ramp_mode (rm) (IDX=%1010) | 22 |
| 8.13 | interrupt_mask & interrupt_flags (IDX=%1011) | 24 |
| 8.14 | pulse_div & ramp_div & usrs (IDX=%1100) | 26 |
| 8.15 | dx_ref_tolerance (IDX=%1101) | 27 |
| 8.16 | x_latched (IDX=%1110) | 27 |
| 8.17 | Unused Address (IDX=%1111) | 27 |
| 9 | Global Parameter Registers | 27 |
| 9.1 | datagram_low_word (JDX=%0000) & datagram_high_word (JDX=%0001) | 27 |
| 9.2 | cover_pos & cover_len (JDX=%0010) | 28 |
| 9.3 | cover_datagram (JDX=%0011) | 28 |
| 9.4 | Unused Addresses (JDX={%0011, ..., %0111, %1001, ..., %1101}) | 29 |
| 9.5 | power_down (JDX=%1000) | 29 |
| 9.6 | Reference Switches l3 & r3 & l2 & r2 & l2 & r1 (JDX=%1110) | 29 |
| 9.7 | Stepper Motor Global Parameter Register (JDX=%1111) | 29 |
| 9.8 | Triple Switch Configuration | 33 |
| 9.9 | Reference Search | 34 |
| 9.10 | Simultaneous Start of up to Three Stepper Motors | 34 |
| 10 | RAM Address Partitioning and Data Organization | 35 |
| 11 | Stepper Motor Driver Datagram Configuration | 36 |
| 11.1 | Initialization of on-chip-RAM by μ C after power-on | 37 |
| 11.2 | An Example of a Stepper Motor Driver Datagram Configuration | 38 |
| 12 | Initialization of the Micro Step Look-Up-Table | 39 |
| 12.1 | Stepping through the Wave Look-Up-Table | 41 |
| 12.2 | Partial look-up table initialization option | 42 |
| 12.3 | Micro Step Enhancement | 43 |
| 13 | How to get Started in Running a Motor | 44 |
| 14 | Package Outlines and Dimensions | 45 |
| 14.1 | Shrink Small Outline Package with 16 Pins (SSOP16, 150 MIL) of TMC428-I and TMC428-A 45 | |
| 14.2 | Small Outline Package with 24 Pins (SOP24) of TMC428-PI24 | 46 |
| 14.3 | Dual-In-Line Package with 20 Pins (DIL20) of TMC428-DI20 | 47 |
| 15 | Marking | 48 |
| 16 | On-Chip Voltage Regulator | 49 |
| 17 | Power-On-Reset | 50 |
| 18 | Characteristics | 51 |
| 19 | Example for Calculation of p_mul and p_div for the TMC428 | 53 |
| 20 | Revision History | 54 |
| 21 | Table of Figures | 56 |
| 22 | Table of Tables | 56 |
| 23 | Table of Contents | 57 |

Please refer to www.trinamic.com for updated data sheets and application notes on this product and on other products.

The TMCtechLIB CD-ROM – including data sheets, application notes, schematics of evaluation boards, software of evaluation boards, source code examples, parameter calculation spreadsheets, tools, and more – is available from TRINAMIC Motion Control GmbH & Co. KG by request.