

APPROVAL SHEET

WR25X

±1%, ±5%

Power chip resistors

Size 2512

Customer : _____

Approval No : _____

Issue Date : _____

Customer Approval :



FEATURE

1. High power rating and compact size
2. High reliability and stability
3. Reduced size of final equipment
4. Lead free product is available.

APPLICATION

- Power supply
- PDA
- Digital meter
- Computer
- Automotives
- Battery charger
- DC-DC power converter

DESCRIPTION

The resistors are constructed in a high grade ceramic body (aluminum oxide). Internal metal electrodes are added at each end and connected by a resistive paste that is applied to the top surface of the substrate. The composition of the paste is adjusted to give the approximate resistance required and the value is trimmed to nominated value within tolerance which controlled by laser trimming of this resistive layer.

The resistive layer is covered with a protective coat. Finally, the two external end terminations are added. For ease of soldering the outer layer of these end terminations is a Lead-tin or Tin (lead free) alloy.

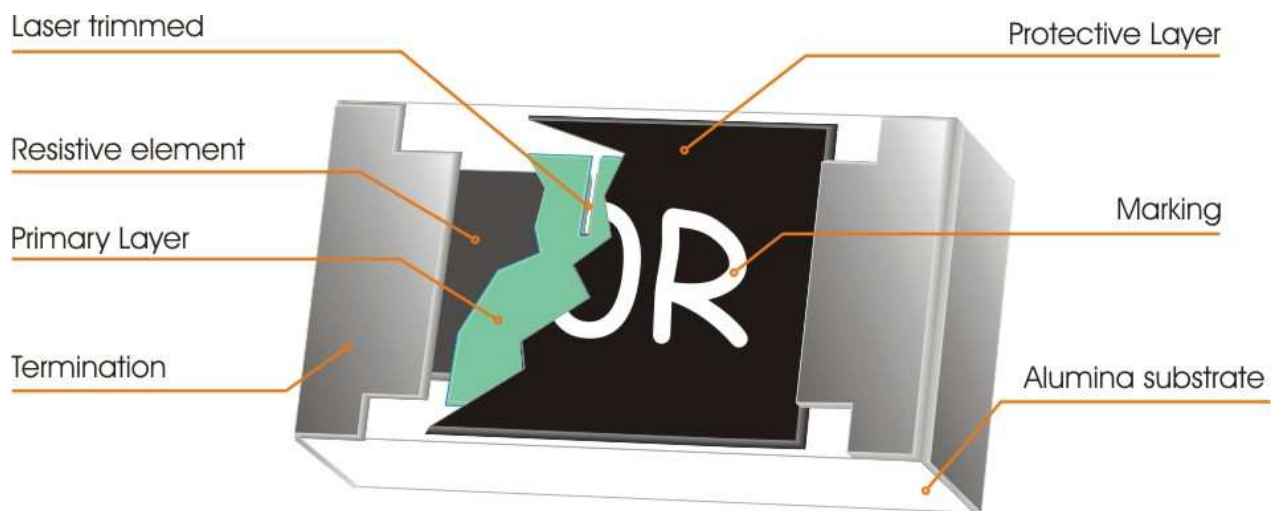

Fig 1. Construction of Chip-R



QUICK REFERENCE DATA

Item	General Specification
Series No.	WR25
Size code	2512(6432)
Resistance Tolerance	±5% (E24); ±1% (E24+E96)
Resistance Range	1Ω ~ 10MΩ, Jumper (0Ω)
TCR (ppm/°C) : 10Ω ≤ Rn < 1MΩ 1Ω ≤ Rn < 9.76Ω & 1MΩ ≤ Rn < 10MΩ	± 100 ppm/°C
	± 300 ppm/°C
Max. dissipation at T _{amb} =70°C	1W
Max. Operation Voltage (DC or RMS)	250V
Max. Overload Voltage (DC or RMS)	500V
Climatic category (IEC 60068)	55/155/56

Note :

1. This is the maximum voltage that may be continuously supplied to the resistor element, see “IEC publication 60115-8”
2. Max. Operation Voltage : So called RCWV (Rated Continuous Working Voltage) is determined by

$$RCWV = \sqrt{\text{Rated Power} \times \text{Resistance Value}}$$
or Max. RCWV listed above, whichever is lower.
3. The resistance of Jumper is defined <0.05Ω, I_{max}. = 0.8A.

MECHANICAL DATA

Symbol	Dimensions (mm)
L	6.40±0.20
W	3.20±0.20
T	0.60±0.10
Tt	0.65±0.25
Tb	0.90±0.25

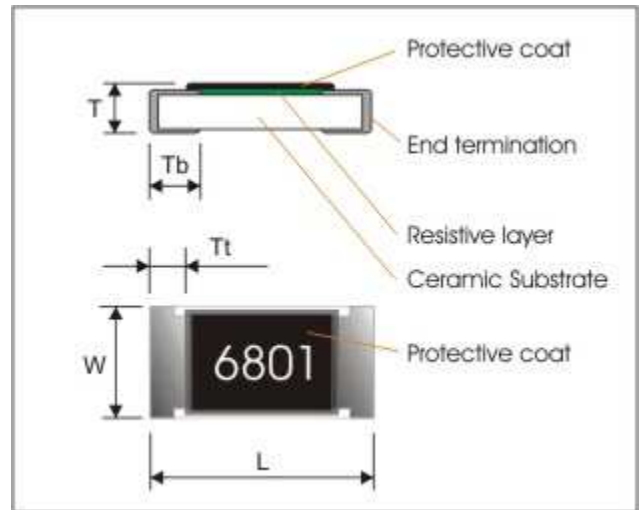

MASS (per 100pcs) : 4.25 gram

MARKING

Each resistor is marked with a four-digit code on the protective coating to designate the nominal resistance value.

Example:

1R00 = 1Ω
1001 = 1000Ω



FUNCTIONAL DESCRIPTION

Product characterization

Standard values of nominal resistance are taken from the E96 & E24 series for resistors with a tolerance of $\pm 5\%$ & $\pm 1\%$. The values of the E24/E96 series are in accordance with "IEC publication 60063".

Derating curve

The power that the resistor can dissipate depends on the operating temperature; see Fig.2

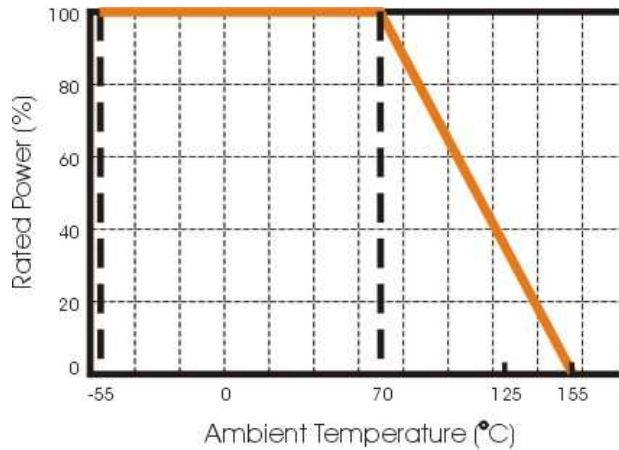

Fig.2 Maximum dissipation in percentage of rated power As a function of the ambient temperature

MOUNTING

Due to their rectangular shapes and small tolerances, Surface Mountable Resistors are suitable for handling by automatic placement systems.

Chip placement can be on ceramic substrates and printed-circuit boards (PCBs).

Electrical connection to the circuit is by individual soldering condition.

The end terminations guarantee a reliable contact.

SOLDERING CONDITION

The robust construction of chip resistors allows them to be completely immersed in a solder bath of 260°C for 10 seconds. Therefore, it is possible to mount Surface Mount Resistors on one side of a PCB and other discrete components on the reverse (mixed PCBs).

Surface Mount Resistors are tested for solderability at 245°C during 3 seconds. The test condition for no leaching is 260°C for 30 seconds. Typical examples of soldering processes that provide reliable joints without any damage are given in Fig 3.

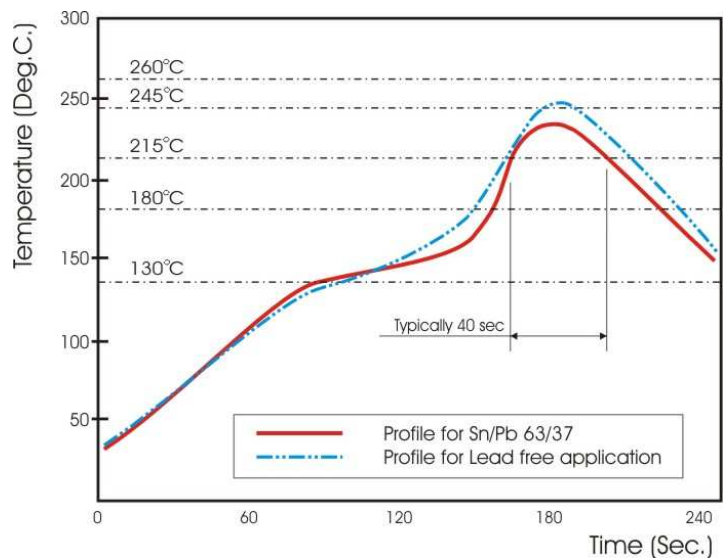

Fig 3. Infrared soldering profile for Chip Resistors

**CATALOGUE NUMBERS**

The resistors have a catalogue number starting with :

WR25	X	472_	J	T	L
Size code WR25 : 2512 WR20 : 2010	Type code X : Normal	Resistance code E24 : 2 significant digits followed by no. of zeros and a blank 4.7Ω =4R7_ 10Ω =100_ 220Ω =221_ Jumper =000_ ("_" means a blank) E96 : 3 significant digits followed by no. of zeros 102Ω =1020 37.4KΩ =3742	Tolerance J : ±5% F : ±1% P : Jumper	Packaging code T : 7" Reel taping	Termination code L = Sn base (lead free)

TEST AND REQUIREMENTS(JIS C 5201-1 : 1998)

Essentially all tests are carried out according to the schedule of IEC publication 115-8, category **LCT/UCT/56** (rated temperature range : **Lower Category Temperature**, **Upper Category Temperature**; damp heat, long term, 56 days). The testing also meets the requirements specified by EIA, EIAJ and JIS.

The tests are carried out in accordance with IEC publication 68, "Recommended basic climatic and mechanical robustness testing procedure for electronic components" and under standard atmospheric conditions according to IEC 60068-1, subclause 5.3. Unless otherwise specified, the following value supplied :

Temperature: 15°C to 35°C.

Relative humidity: 45% to 75%.

Air pressure: 86kPa to 106 kPa (860 mbar to 1060 mbar).

All soldering tests are performed with mildly activated flux.

TEST	PROCEDURE / TEST METHOD	REQUIREMENT	
		Resistor	0Ω
DC resistance Clause 4.5	DC resistance values measured at the test voltages specified below : <10Ω@0.1V, <100Ω@0.3V, <1KΩ@1.0V, <10KΩ@3V, <100KΩ@10V, <1MΩ@25V, <10MΩ@30V	Within the specified tolerance	<50mΩ
Temperature Coefficient of Resistance(T.C.R) Clause 4.8	Natural resistance change per change in degree centigrade. $\frac{R_2 - R_1}{R_1(t_2 - t_1)} \times 10^6 \text{ (ppm/°C)}$ $t_1 : 20^\circ\text{C}+5^\circ\text{C}-1^\circ\text{C}$ R ₁ : Resistance at reference temperature R ₂ : Resistance at test temperature	Refer to "QUICK REFERENCE DATA"	N/a
Short time overload (S.T.O.L) Clause 4.13	Permanent resistance change after a 5second application of a voltage 2.5 times RCWV or the maximum overload voltage specified in the above list, whichever is less.	ΔR/R max. ±(2%+0.10Ω)	<50mΩ
Resistance to soldering heat(R.S.H) IEC 60068-2-58: 2004	Un-mounted chips completely immersed for 10±1second in a SAC solder bath at 255°C±5°C	Δ R/R max. ±(1%+0.05Ω) no visible damage	<50mΩ
Solderability IEC 60068-2-58: 2004	Un-mounted chips completely immersed for 3±0.3second in a SAC solder bath at 245°C±5°C	95% coverage min., good tinning and no visible damage	
Temperature cycling Clause 4.19	30 minutes at -55°C±3°C, 2~3 minutes at 20°C+5°C-1°C, 30 minutes at +155°C±3°C, 2~3 minutes at 20°C+5°C-1°C, total 5 continuous cycles	ΔR/R max. ±(1%+0.05Ω)	< 50mΩ
Load life in Humidity Clause 4.24	1000 +48/-0 hours, loaded with RCWV or Vmax in humidity chamber controller at 40°C±2°C and 90~95% relative humidity , 1.5hours on and 0.5 hours off	ΔR/R max. ±(3%+0.1Ω)	< 50mΩ
Load Life(Endurance) Clause 4.25	1000 +48/-0 hours, loaded with RCWV or Vmax in chamber controller 70±2°C, 1.5 hours on and 0.5 hours off	Ditto.	
Bending strength Clause 4.33	Resistors mounted on a 90mm glass epoxy resin PCB(FR4), bending once 2mm for 10sec.	No visual damaged, ΔR/R max. ±(1%+0.05Ω)	< 50mΩ
Adhesion Clause 4.32	Pressurizing force: 5N, Test time: 10±1sec.	No remarkable damage or removal of the terminations	
Insulation Resistance JISC5201-1:1998 Clause 4.6	Apply the maximum overload voltage (DC) for 1minutes	R ≥ 10GΩ	
Dielectric Withstand Voltage JISC5201-1:1998 Clause 4.7	Apply the maximum overload voltage (AC) for 1 minutes	No breakdown or flashover	

PACKAGING

Plastic tape specifications (unit :mm)

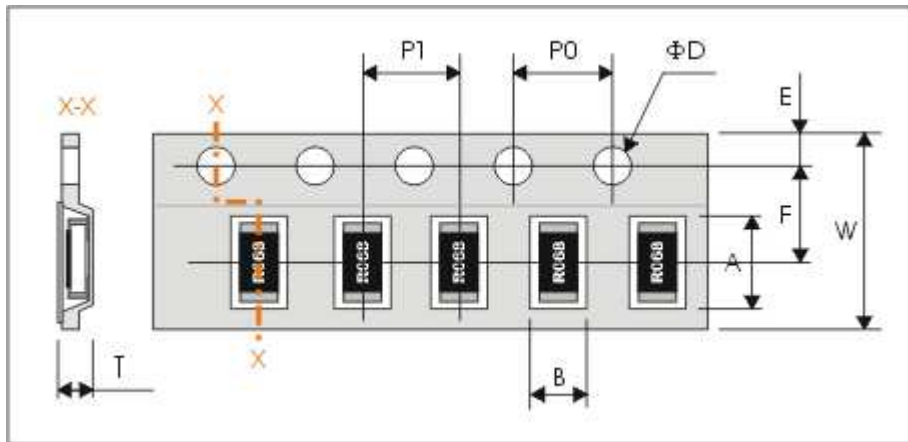

Symbol	A	B	W	F	E
Dimensions	6.90±0.20	3.60±0.20	12.00±0.30	5.50±0.1	1.75±0.10

Symbol	P1	P0	ΦD	T
Dimensions	4.00±0.10	4.00±0.10	Φ1.50 ^{+0.1} _{-0.0}	Max. 1.2

Reel dimensions

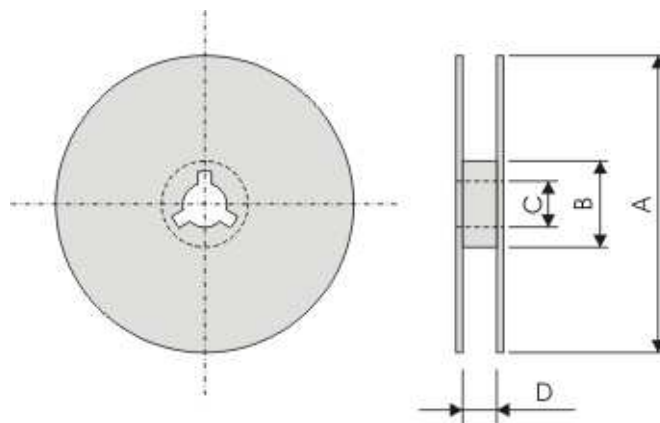

Symbol	A	B	C	D
(unit : mm)	Φ178.0±2.0	Φ60.0±1.0	13.0±0.2	14.0±0.2

Taping quantity

- Chip resistors 4,000 pcs per reel.