

N-Channel Enhancement Mode Field Effect Transistor

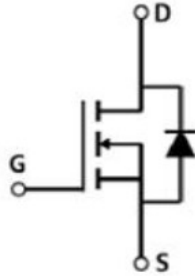

TO-220

Product Summary

- V_{DS} 60V
- I_D 200A
- $R_{DS(ON)}$ (at $V_{GS}=10V$) <2.9 mohm
- $R_{DS(ON)}$ (at $V_{GS}=4.5V$) <3.6 mohm
- 100% UIS Tested
- 100% ∇V_{DS} Tested

General Description

- Split Gate Trench MOSFET technology
- Excellent package for heat dissipation
- High density cell design for low $R_{DS(ON)}$

Applications

- Consumer electronic power supply
- Isolated DC-DC Converters
- Motor control
- Invertors

■ Absolute Maximum Ratings ($T_A=25^\circ\text{C}$ unless otherwise noted)

Parameter		Symbol	Limit	Unit
Drain-source Voltage		V_{DS}	60	V
Gate-source Voltage		V_{GS}	± 20	V
Drain Current ^A	$T_C=25^\circ\text{C}$	I_D	200	A
	$T_C=100^\circ\text{C}$		125	
Pulsed Drain Current ^B		I_{DM}	600	A
Avalanche energy ^C		E_{AS}	500	mJ
Total Power Dissipation ^D		P_D	260	W
Thermal Resistance Junction-to-Case		$R_{\theta JC}$	0.48	$^\circ\text{C}/\text{W}$
Thermal Resistance Junction-to-Ambient ^E		$R_{\theta JA}$	28	
Junction and Storage Temperature Range		T_J, T_{STG}	-55~+150	$^\circ\text{C}$

■ Ordering Information (Example)

PREFERRED P/N	PACKING CODE	Marking	MINIMUM PACKAGE(pcs)	INNER BOX QUANTITY(pcs)	OUTER CARTON QUANTITY(pcs)	DELIVERY MODE
YJP200G06A	B1	YJP200G06A	50	/	5000	Tube



YJP200G06A

■ Electrical Characteristics (T_J=25°C unless otherwise noted)

Parameter	Symbol	Conditions	Min	Typ	Max	Units
Static Parameter						
Drain-Source Breakdown Voltage	BV _{DSS}	V _{GS} = 0V, I _D =250μA	60			V
Zero Gate Voltage Drain Current	I _{DSS}	V _{DS} =60V, V _{GS} =0V			1	μA
Gate-Body Leakage Current	I _{GSS}	V _{GS} = ±20V, V _{DS} =0V			±100	nA
Gate Threshold Voltage	V _{GS(th)}	V _{DS} = V _{GS} , I _D =250μA	1.2	1.6	2.2	V
Static Drain-Source On-Resistance	R _{DS(on)}	V _{GS} = 10V, I _D =20A		2.35	2.9	mΩ
		V _{GS} = 4.5V, I _D =15A		2.9	3.6	
Diode Forward Voltage	V _{SD}	I _S =20A, V _{GS} =0V			1.2	V
Maximum Body-Diode Continuous Current	I _S				200	A
Dynamic Parameters						
Input Capacitance	C _{iss}	V _{DS} =25V, V _{GS} =0V, f=100KHZ		5950		pF
Output Capacitance	C _{oss}			1250		
Reverse Transfer Capacitance	C _{rss}			85		
Switching Parameters						
Total Gate Charge	Q _g	V _{GS} =10V, V _{DS} =50V, I _D =50A		93		nC
Gate-Source Charge	Q _{gs}			17		
Gate-Drain Charge	Q _{gd}			14		
Reverse Recovery Charge	Q _{rr}	I _F =25A, di/dt=100A/us		73		
Reverse Recovery Time	t _{rr}			68		
Turn-on Delay Time	t _{d(on)}	V _{GS} =10V, V _{DD} =30V, I _D =25A R _{GEN} =2Ω		22.5		ns
Turn-on Rise Time	t _r			6.7		
Turn-off Delay Time	t _{d(off)}			80.3		
Turn-off fall Time	t _f			26.9		

Note:

- The maximum current rating is package limited.
- Repetitive rating; pulse width limited by max. junction temperature.
- V_{DD}=50 V, R_G=25 Ω, L=0.5mH, starting T_J=25 °C.
- P_D is based on max. junction temperature, using junction-case thermal resistance.
- The value of R_{θJA} is measured with the device mounted on 1 in 2 FR-4 board with 2oz. Copper, in a still air environment with T_a=25 °C.



■ Typical Performance Characteristics

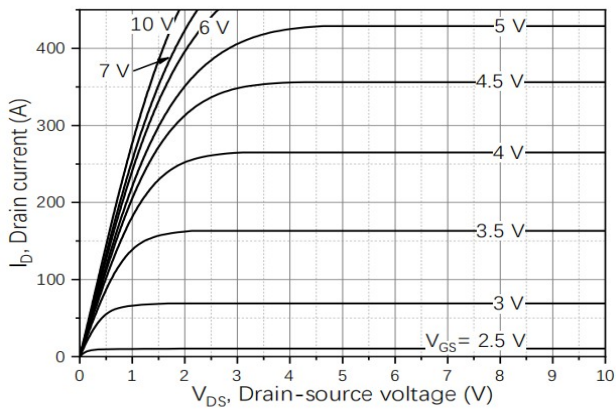

Figure1. Output Characteristics

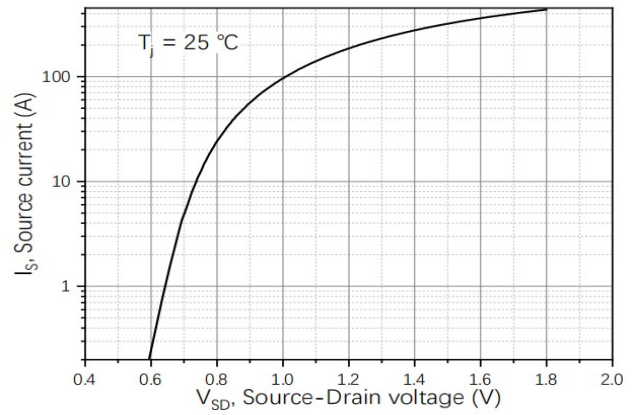

Figure2. Transfer Characteristics

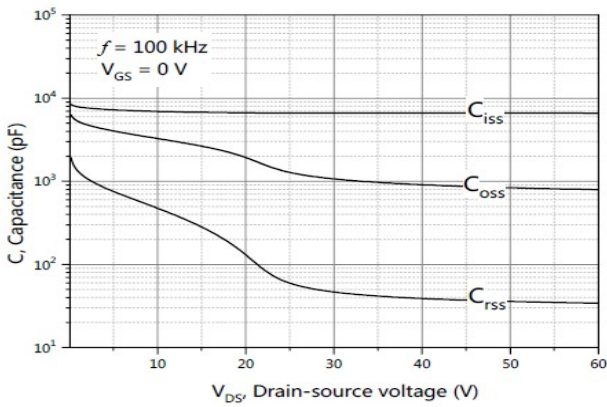

Figure3. Capacitance Characteristics

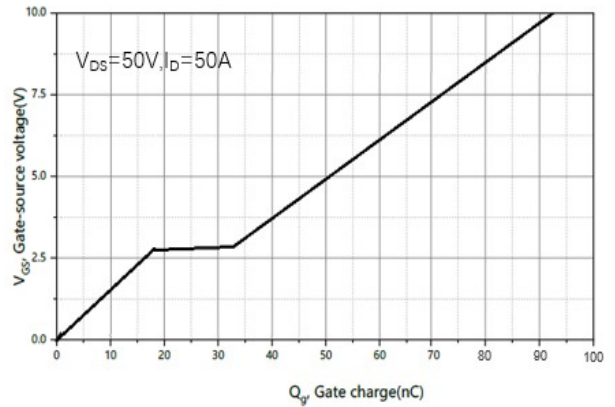

Figure4. Gate Charge

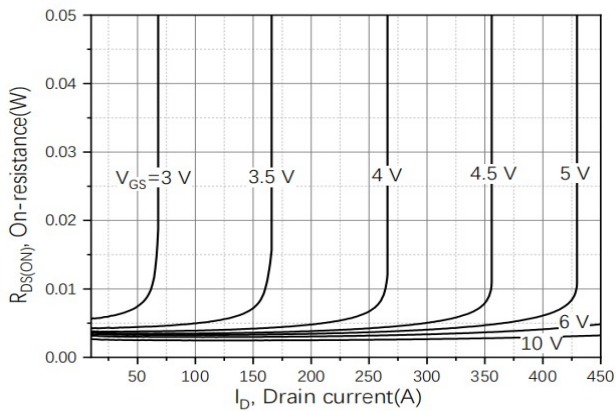

Figure5. Drain-Source on Resistance

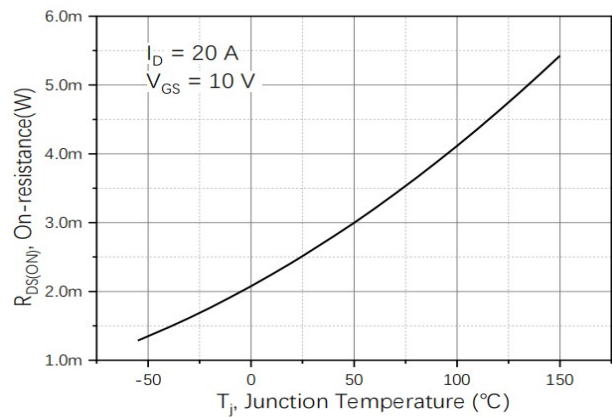

Figure6. Drain-Source on Resistance



YJP200G06A

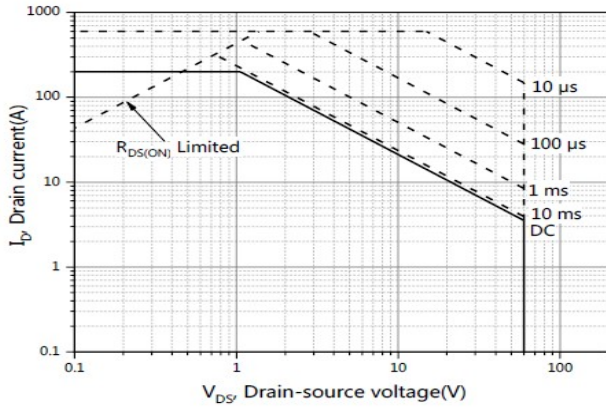

Figure7. Safe Operation Area

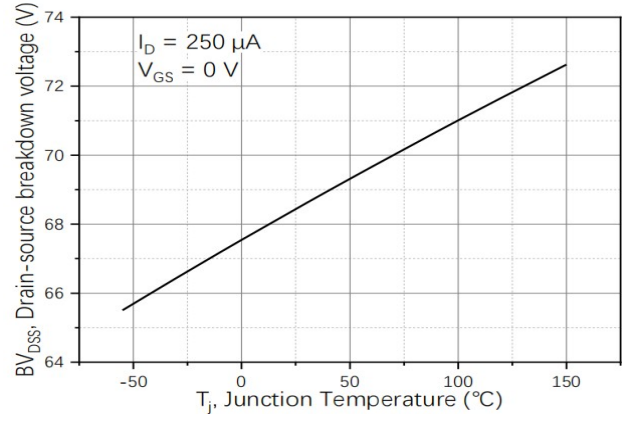

Figure8. Drain-source breakdown voltage

■ Test circuits and waveforms

Figure A: Gate Charge Test Circuit & Waveforms

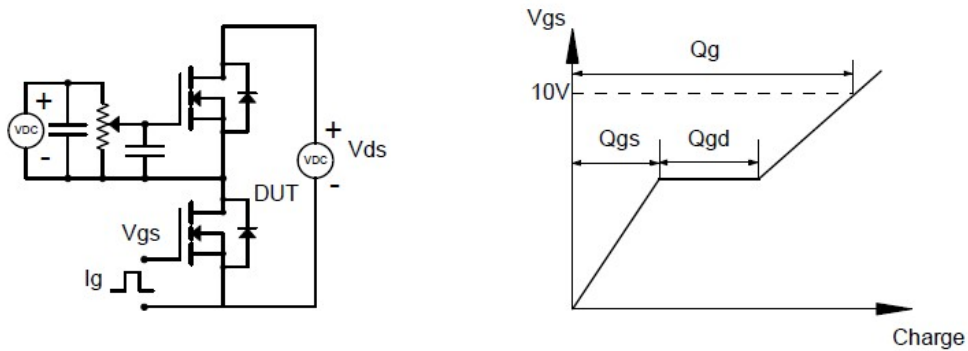

Figure B: Resistive Switching Test Circuit & Waveforms

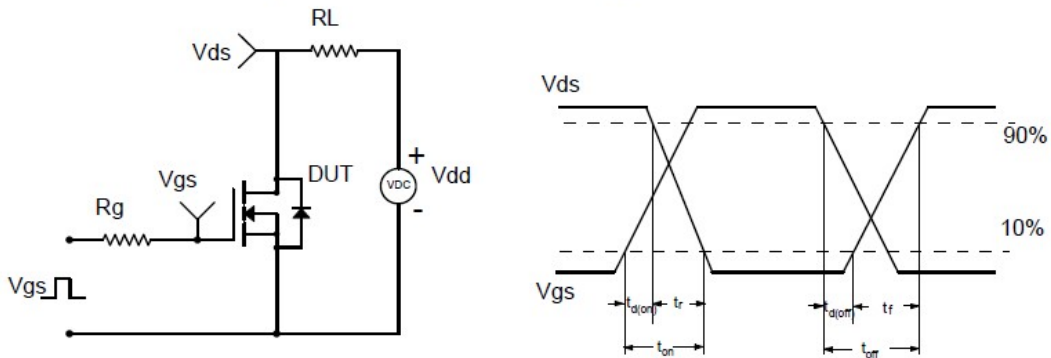

Figure C: Unclamped Inductive Switching (UIS) Test

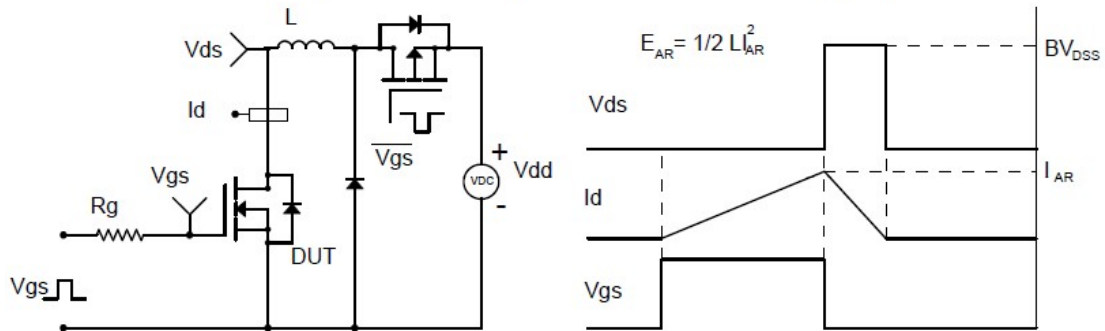
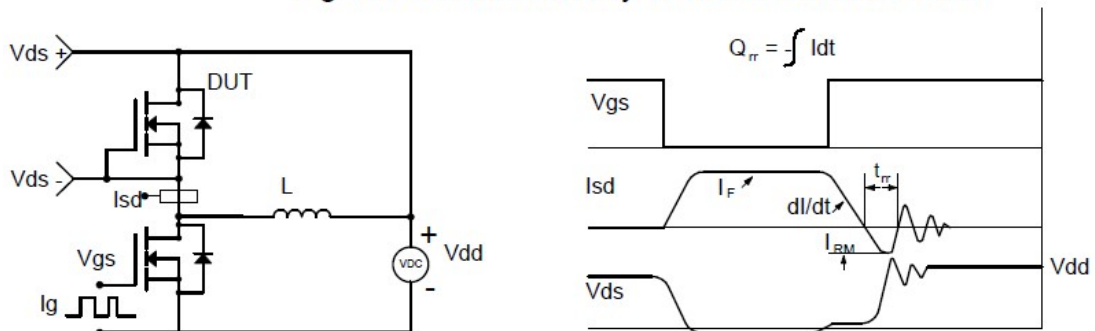

Figure D: Diode Recovery Test Circuit & Waveforms





YJP200G06A

TO-220 Package Information

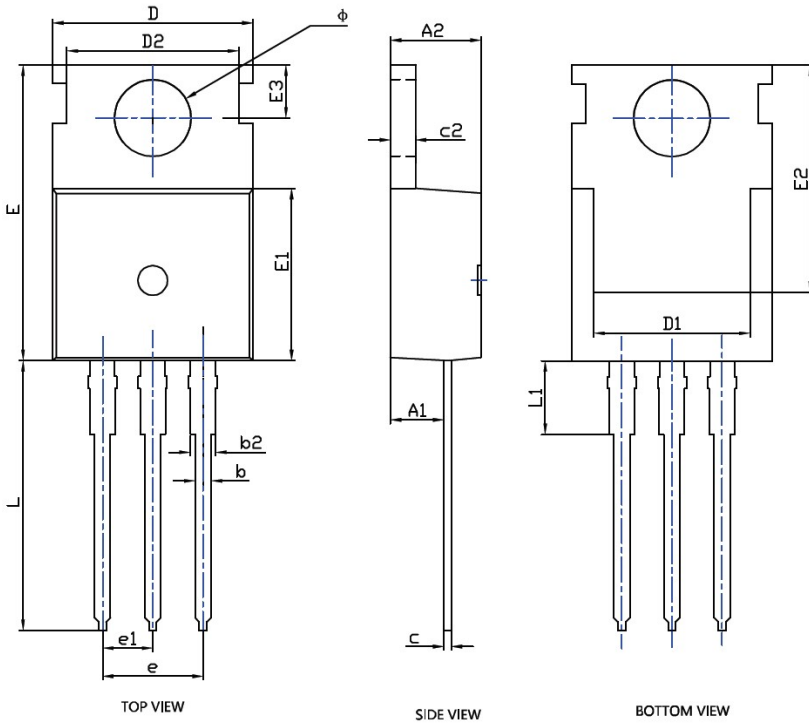

SYMBOL	DIMENSIONS					
	INCHES			Millimeter		
	MIN.	NDM.	MAX.	MIN.	NDM.	MAX.
A1	0.091	0.094	0.098	2.300	2.400	2.500
A2	0.173	0.177	0.181	4.400	4.500	4.600
b	0.028	0.031	0.035	0.700	0.800	0.900
b2	0.049	0.052	0.056	1.250	1.330	1.420
c	0.018	0.020	0.022	0.450	0.500	0.550
c2	0.050	0.051	0.052	1.270	1.300	1.330
D	0.382	---	0.402	9.700	---	10.200
D1	0.299	0.315	0.331	7.600	8.000	8.400
D2	0.335	0.343	0.350	8.500	8.700	8.900
E	0.602	0.618	0.634	15.300	15.700	16.100
E1	0.358	0.362	0.366	9.100	9.200	9.300
E2	0.497	0.505	0.513	12.630	12.830	13.030
E3	0.108BSC			2.750BSC		
e	0.200BSC			5.080BSC		
e1	0.100BSC			2.540BSC		
L	0.512	---	0.531	13.000	---	13.500
L1	---	---	0.138	---	---	3.500
ϕ	0.140	0.144	0.148	3.550	3.650	3.750

NOTE:
 1. PACKAGE BODY SIZES EXCLUDE MOLD FLASH AND GATE BURRS.
 2. TOLERANCE 0.1mm UNLESS OTHERWISE SPECIFIED.



YJP200G06A

Disclaimer

The information presented in this document is for reference only. Yangzhou Yangjie Electronic Technology Co., Ltd. reserves the right to make changes without notice for the specification of the products displayed herein to improve reliability, function or design or otherwise.

The product listed herein is designed to be used with ordinary electronic equipment or devices, and not designed to be used with equipment or devices which require high level of reliability and the malfunction of which would directly endanger human life (such as medical instruments, transportation equipment, aerospace machinery, nuclear-reactor controllers, fuel controllers and other safety devices), Yangjie or anyone on its behalf, assumes no responsibility or liability for any damages resulting from such improper use of sale.

This publication supersedes & replaces all information previously supplied. For additional information, please visit our website [http:// www.21yangjie.com](http://www.21yangjie.com) , or consult your nearest Yangjie's sales office for further assistance.